

HISTORY INFORMATION FOR THE FOLLOWING MANUAL:

SERVICE MANUAL

ORIGINAL MANUAL ISSUE DATE: 3/2015

GN1T CHASSIS
Segment: XF

Version	Date	Subject
1.0	3/2015	Original manual issue.

LCD TV

SONY®

SERVICE MANUAL

GN1T CHASSIS
Segment: XF

LCD TV

SONY®

MODEL LIST

<i>MODEL</i>	<i>COLOR</i>	<i>COMMANDER</i>	<i>DEST.</i>
XBR-55X850C	Black	RMF-TX100U	(LA1)
		RMT-TX100U	PUERTO RICO MX CHILE, PERU (UC2) US/CND
XBR-55X855C	Silver	RMF-TX100U	(BR6)
		RMT-TX100B	BRAZIL
	Black	RMF-TX100U	(CR1)
		RMT-TX100B	COSTA RICA (ECU) ECUADOR (LA8) CHILE PERU VENEZUELA
XBR-55X857C	Black	RMF-TX100U	(CO1)
		RMT-TX100B	COLOMBIA
XBR-65X850C	Black	RMF-TX100U	(UC2)
		RMT-TX100U	US/CND

<i>MODEL</i>	<i>COLOR</i>	<i>COMMANDER</i>	<i>DEST.</i>		
XBR-65X855C	Silver	RMF-TX100U	(BR6)		
		RMT-TX100B	BRAZIL		
	Black	RMF-TX100U	(AR4)		
		RMT-TX100B	ARGENTINA (CR1) COSTA RICA (LA8) CHILE PERU VENEZUELA		
XBR-65X857C	Black	RMF-TX100B	(CO1)		
		RMT-TX100B	COLOMBIA		
XBR-75X850C	Black	RMF-TX100U	(LA1)		
		RMT-TX100U	PUERTO RICO MX CHILE, PERU (UC2) US/CND		
		XBR-75X855C	Silver	RMF-TX100U	(BR6)
				RMT-TX100B	BRAZIL

WARNINGS AND CAUTIONS - ENGLISH

CAUTION

These servicing instructions are for use by qualified service personnel only.

To reduce the risk of electric shock, do not perform any servicing other than that contained in the operating instructions unless you are qualified to do so.

WARNING!!

An isolation transformer should be used during any service to avoid possible shock hazard, because of live chassis.

The chassis of this receiver is directly connected to the ac power line.

CARRYING THE TV

Be sure to follow these guidelines to protect your property and avoid causing serious injury.

- Carry the TV with an adequate number of people; larger size TVs require two or more people.
- Correct hand placement while carrying the TV is very important for safety and to avoid damages.

SAFETY-RELATED COMPONENT WARNING!!

Components identified by shading and ⚠ mark on the schematic diagrams, exploded views, and in the parts list are critical for safe operation. Replace these components with Sony parts whose part numbers appear as shown in this manual or in supplements published by Sony. Circuit adjustments that are critical for safe operation are identified in this manual.

Follow these procedures whenever critical components are replaced or improper operation is suspected.

CAUTION ABOUT THE LITHIUM BATTERY

- Danger of explosion if battery is incorrectly replaced. Replace only with the same or equivalent type.
- Outer case broken battery should not contact to water.

WARNINGS AND CAUTIONS - FRENCH

ATTENTION!!

Ces instructions de service sont à l'usage du personnel de service qualifié seulement.

Pour prévenir le risque de choc électrique, ne pas faire l'entretien autre que celui contenu dans le Mode d'emploi à moins que vous soyez qualifié pour faire ainsi.

WARNING!!

Afin d'éviter tout risque d'électrocution provenant d'un châssis sous tension, un transformateur d'isolement doit être utilisé lors de tout dépannage. Le châssis de ce récepteur est directement raccordé à l'alimentation du secteur.

POUR TRANSPORTER LE TÉLÉVISEUR

Tenez compte de ce qui suit pendant l'installation du téléviseur :

- Débranchez tous les câbles avant de transporter le téléviseur.
- Transportez le téléviseur avec le nombre de personnes approprié ; un téléviseur de grande taille doit être transporté par au moins deux personnes.
- Lors du transport du téléviseur, l'emplacement des mains est très important pour votre sécurité, ainsi que pour éviter de causer des dommages.

ALERTE!!

Afin d'éviter tout risque d'électrocution provenant d'un châssis sous tension, un transformateur d'isolement doit être utilisé lors de tout dépannage. Le châssis de ce récepteur est directement raccordé à l'alimentation du secteur.

ATTENTION AUX COMPOSANTS RELATIFS A LA SECURITE!!

Les composants identifiés par une trame et par une marque  sur les schémas de principe, les vues explosées et les listes de pièces sont d'une importance critique pour la sécurité du fonctionnement. Ne les remplacer que par des composants Sony dont le numéro de pièce est indiqué dans le présent manuel ou dans des suppléments publiés par Sony. Les réglages de circuit dont l'importance est critique pour la sécurité du fonctionnement sont identifiés dans le présent manuel. Suivre ces procédures lors de chaque remplacement de composants critiques, ou lorsqu'un mauvais fonctionnement suspecte.

USE CAUTION WHEN HANDLING THE LCD PANEL

When repairing the LCD panel, be sure you are grounded by using a wrist band.

When repairing the LCD panel on the wall, the LCD panel must be secured using the 4 mounting holes on the rear cover.

- 1) Do not press on the panel or frame edge to avoid the risk of electric shock.
- 2) Do not scratch or press on the panel with any sharp objects.
- 3) Do not leave the module in high temperatures or in areas of high humidity for an extended period of time.
- 4) Do not expose the LCD panel to direct sunlight.
- 5) Avoid contact with water. It may cause a short circuit within the module.
- 6) Disconnect the AC power when replacing the backlight (CCFL) or inverter circuit. (High voltage occurs at the inverter circuit at 650Vrms.)
- 7) Always clean the LCD panel with a soft cloth material.
- 8) Use care when handling the wires or connectors of the inverter circuit. Damaging the wires may cause a short.
- 9) Protect the panel from ESD to avoid damaging the electronic circuit (C-MOS).

- 10) It is recommended not to exceed 1 hour of Power-On nor Burn-in period with LCD panel face down condition, in repair activity.

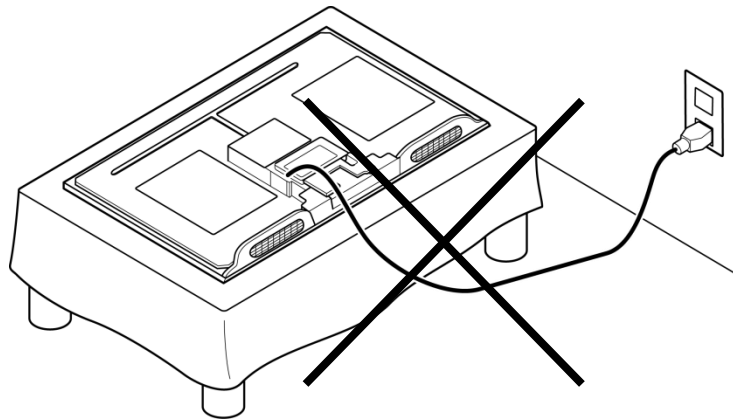

SAFETY CHECK-OUT

After correcting the original service problem, perform the following safety checks before releasing the set to the customer:

1. Check the area of your repair for unsoldered or poorly soldered connections. Check the entire board surface for solder splashes and bridges.
2. Check the interboard wiring to ensure that no wires are “pinched” or touching high-wattage resistors.
3. Check that all control knobs, shields, covers, ground straps, and mounting hardware have been replaced. Be absolutely certain that you have replaced all the insulators.
4. Look for unauthorized replacement parts, particularly transistors, that were installed during a previous repair. Point them out to the customer and recommend their replacement.
5. Look for parts which, though functioning, show obvious signs of deterioration. Point them out to the customer and recommend their replacement.
6. Check the line cords for cracks and abrasion. Recommend the replacement of any such line cord to the customer.
7. Check the antenna terminals, metal trim, “metallized” knobs, screws, and all other exposed metal parts for AC leakage. Check leakage as described below.
8. For safety reasons, repairing the Power board and/or Inverter board is prohibited.

Leakage Test

The AC leakage from any exposed metal part to earth ground and from all exposed metal parts to any exposed metal part having a return to chassis, must not exceed 0.5 mA (500 microamperes).

Leakage current can be measured by any one of three methods.

1. A commercial leakage tester, such as the Simpson 229 or RCA WT-540A. Follow the manufacturers' instructions to use these instructions.
2. A battery-operated AC milliammeter. The Data Precision 245 digital multimeter is suitable for this job.
3. Measuring the voltage drop across a resistor by means of a VOM or battery-operated AC voltmeter. The "limit" indication is 0.75 V, so analog meters must have an accurate low voltage scale. The Simpson's 250 and Sanwa SH-63TRD are examples of passive VOMs that are suitable. Nearly all battery-operated digital multimeters that have a 2 VAC range are suitable (see Figure A).

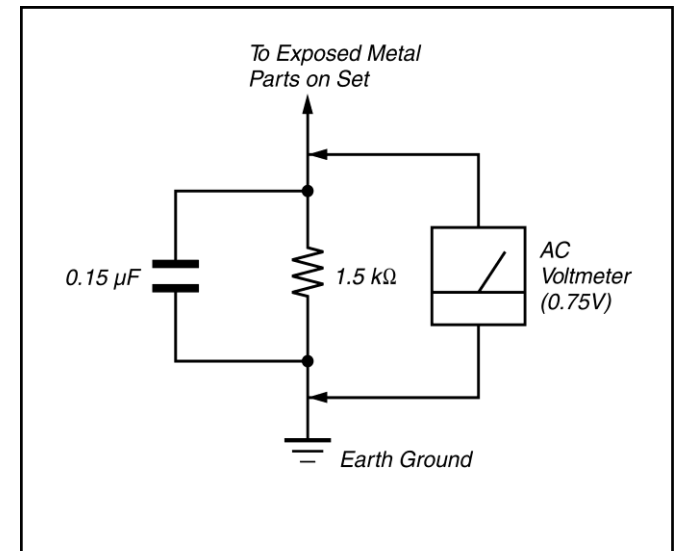

Figure A. Using an AC voltmeter to check AC leakage.

How to Find a Good Earth Ground

A cold-water pipe is a guaranteed earth ground; the cover-plate retaining screw on most AC outlet boxes is also at earth ground.

If the retaining screw is to be used as your earth ground, verify that it is at ground by measuring the resistance between it and a cold-water pipe with an ohmmeter. The reading should be zero ohms.

If a cold-water pipe is not accessible, connect a 60- to 100-watt trouble-light (not a neon lamp) between the hot side of the receptacle and the retaining screw. Try both slots, if necessary, to locate the hot side on the line; the lamp should light at normal brilliance if the screw is at ground potential (see Figure B).

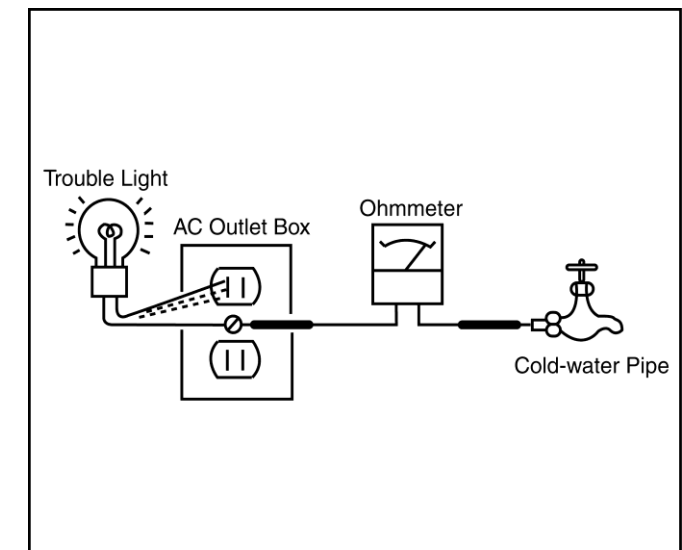

Figure B. Checking for earth ground.

SELF DIAGNOSIS FUNCTION

The units in this manual contain a self-diagnostic function. If an error occurs, the Smart Core Red LED will automatically begin to flash.

The number of times the LED flashes translates to a probable source of the problem.

A definition of the Smart Core Red LED flash indicators is listed in the instruction manual for the user's knowledge and reference.

If an error symptom cannot be reproduced, the remote commander can be used to review the failure occurrence data stored in memory to reveal past problems and how often these problems occur.

DIAGNOSTIC TEST INDICATORS

When an error occurs, the Smart Core Red LED will flash a set number of times to indicate the possible cause of the problem.

If there is more than one error, the LED will identify the first of the problem areas.

Result for all of the following diagnostic items are displayed on screen.

If the screen displays a "0", no error has occurred .

<G>: Power supply board, : Main board, <T>: Tcon board,
<P>: Panel module , <S>: Speaker , <A>: Power Adapter

RED LED blinking count	Detection Items
2x	<G/B> Main 12V over voltage [MAIN_POWER]
3x	 Main 5.0V failure [DC_ALERT]
	<B/S> Audio amp. protection [AUD_ERR] Tuner or demodulator I2C No ACK [TU_DEMOD] HDMI Switch/Equalizer I2C communication error [HDMI_EQ]
	None
4x	<P/T/G/B> <i>Panel ID EEPROM I2C No ACK (Also panel power failure is a suspect)</i> [P_ID_ERR]
	<T> TCon IC I2C communication error [TCON_ERR]
5x	<G/P/B> Backlight failure [BACKLIGHT]
6x	Over temperature protection [TEMP_ERR] Temp. sensor I2C No ACK [TEMP_ERR] V By One lock error between Main device and 4KBE device [4KBE_ERR]
	 Software error [SW_ERR]

Red italic: detect at startup sequence only.

[SELF DIAGNOSTIC SCREEN DISPLAY]

Format of error timestamps

YYMMDDhhmmss (in UTC)

Example:

120823132523 -> Aug 23 2012 13:25:23 UTC

* Only when time is set, an error timestamp is saved.

Smart Core Red LED blinking count

•Panel Operation Time is recorded every 30 min, but Total Operation Time is recorded every 1 hr. Therefore, the panel op. time might become larger than the total op. time.

Total Operation Time [hr] – Boot Count – Panel Operation Time [hr]

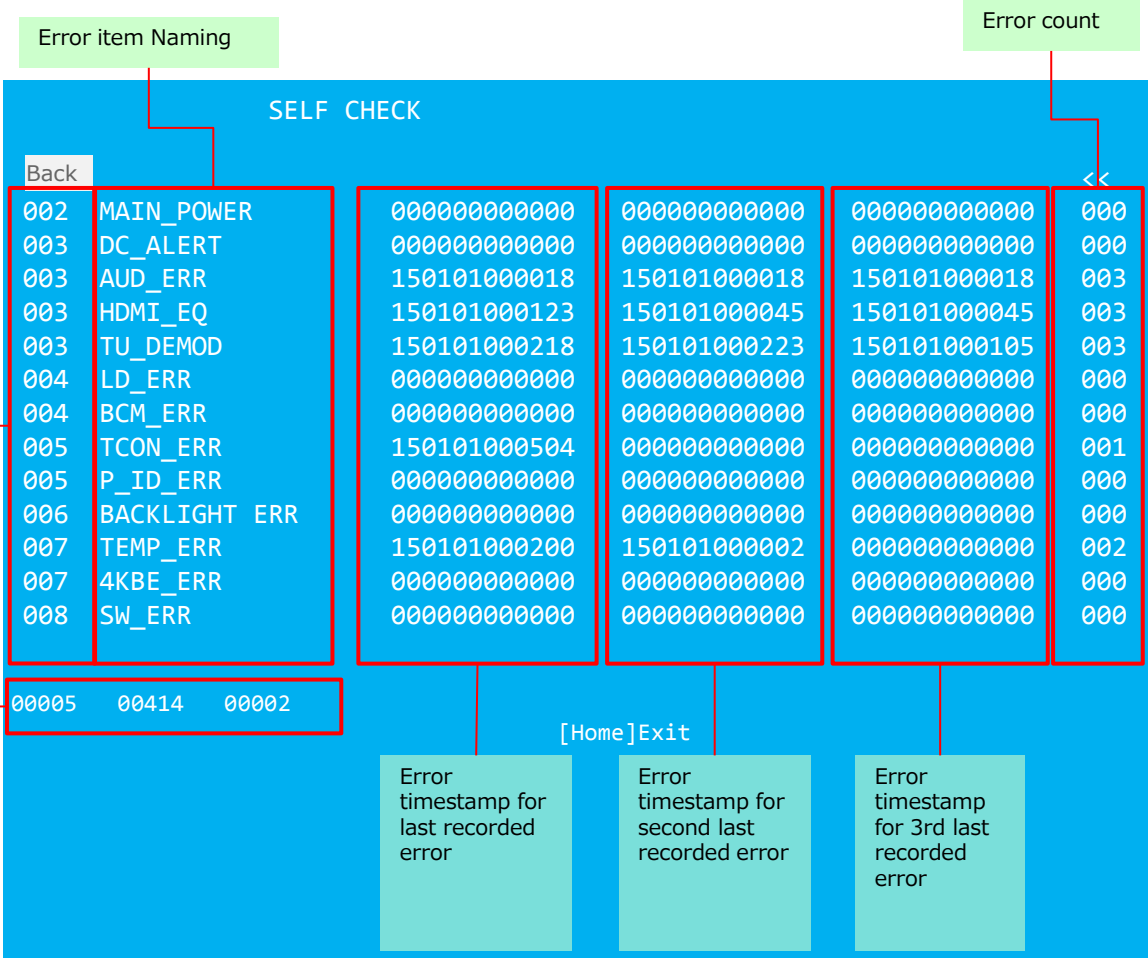

SELF-DIAGNOSTIC SCREEN DISPLAY

For errors with symptoms such as “power sometimes shuts off” or “screen sometimes goes out” that cannot be confirmed, it is possible to bring up past occurrences of failure for confirmation on the screen:

[To Bring Up Screen Test]

In standby mode, press buttons on the remote commander sequentially in rapid succession as shown below:

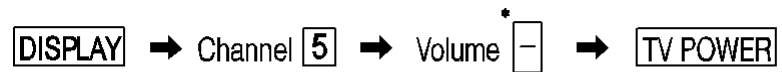

* : Note that this differs from entering the service mode (volume +)

Since the diagnostic results displayed on the screen are not automatically cleared, always check the self-diagnostic screen. After you have completed the repairs, clear the result display to “0”.

Clearing the Self Check Diagnostic List

Panel operation time :

Press the Channel 7 => Channel 0 .

Exiting the Self-diagnostic screen

To exit the Self Diagnostic screen, Power off & on or Push the <Home> button.

SEC 1. DISASSEMBLY

- There are clutch in the yellow frame[]. Therefore please be careful in the case of the disassembly or assembly of parts.

1-1. XBR-55X850C/855C/857C

1-1-1. STAND

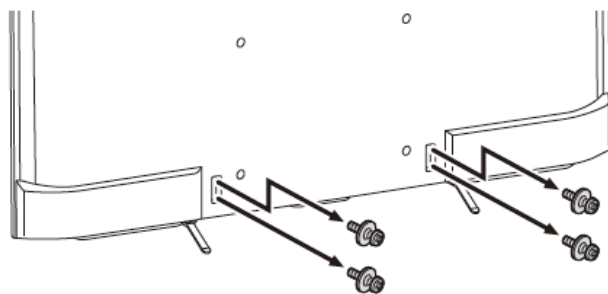

4 screws (SCREW, +PSW M5X16) P/N: 4-449-743-01

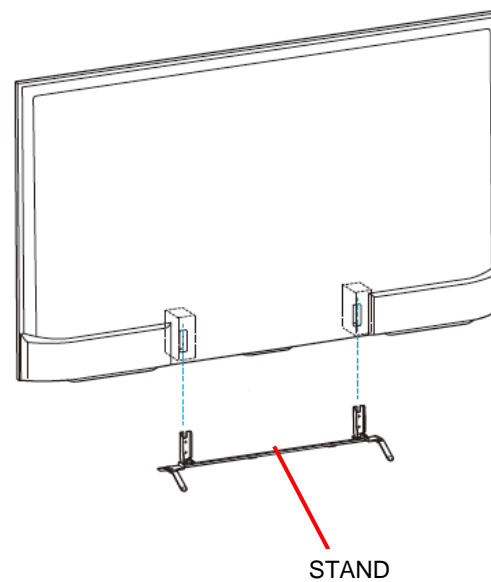

1-1. XBR-55X850C/855C/857C

1-1-2. LABEL, UNDER TERMINAL AND LABEL, REAR TERMINAL AND LABEL, SIDE TERMINAL (L) AND LABEL, CI

(CO1 ONLY)

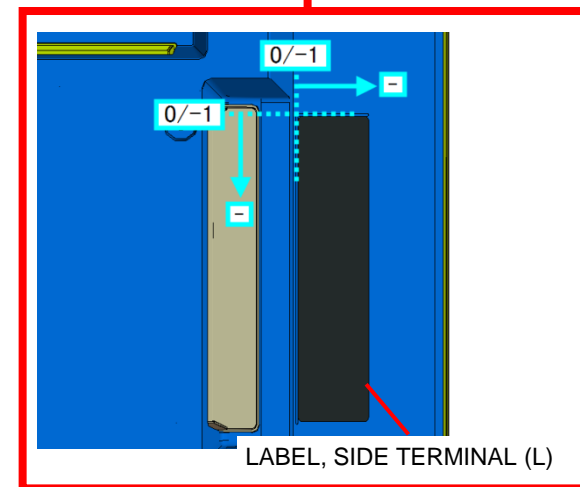
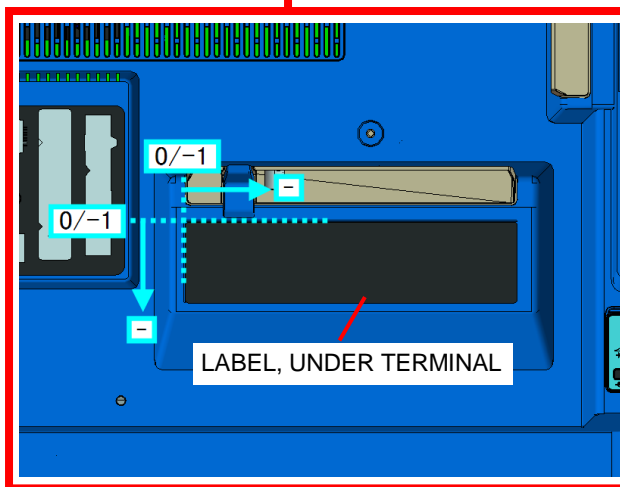
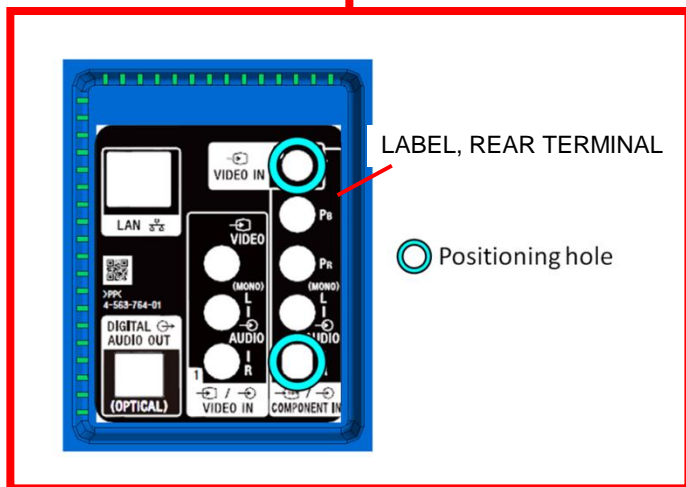
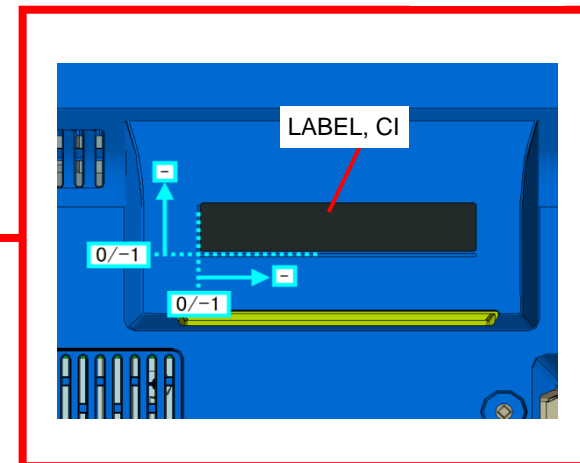
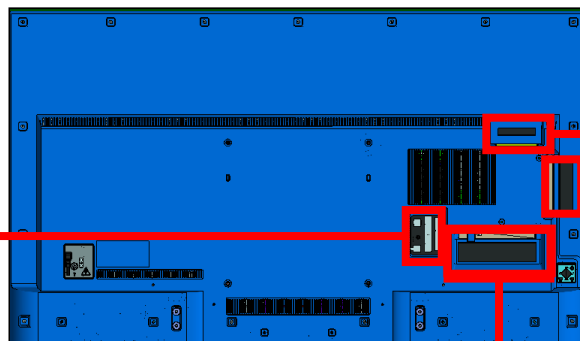

1-1. XBR-55X850C/855C/857C

1-1-3. AC COVER AND POWER SUPPLY CORD

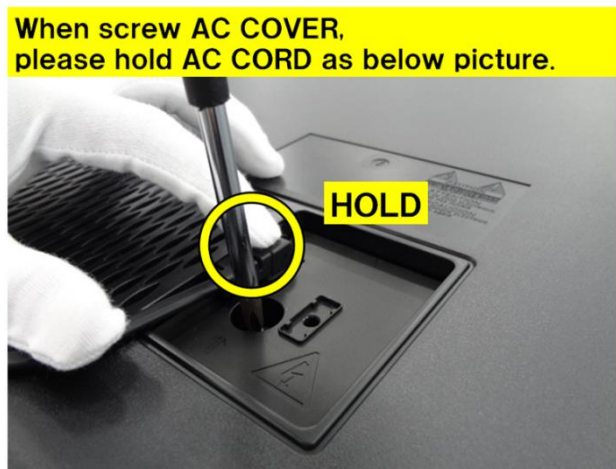
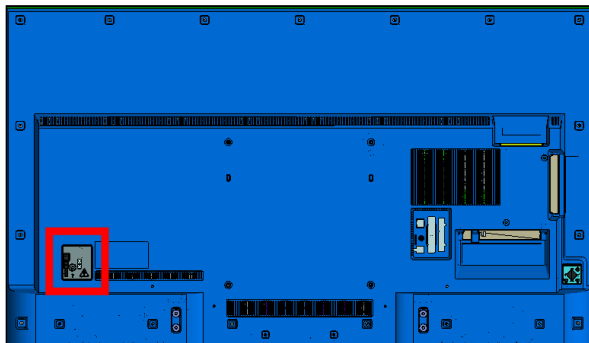

1

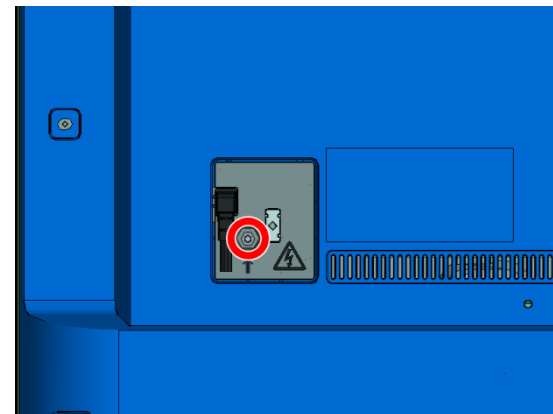

Screw (SCREW +PSW M4X10) P/N: 4-159-298-01

2

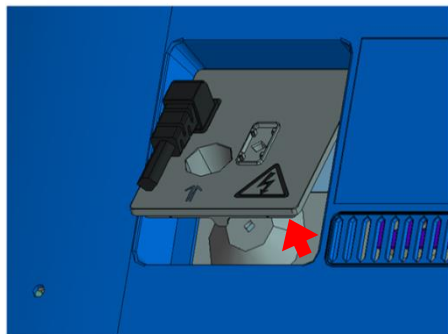

3

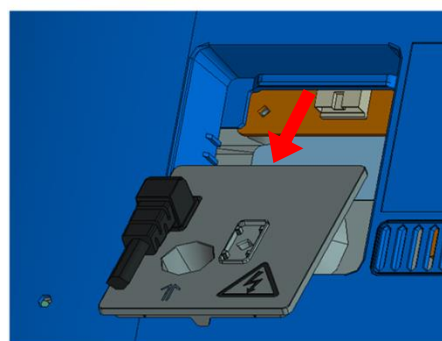

4

POWER SUPPLY CORD

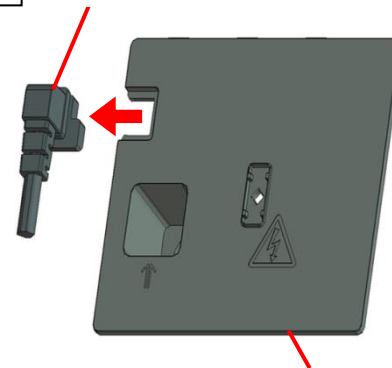

AC COVER

5

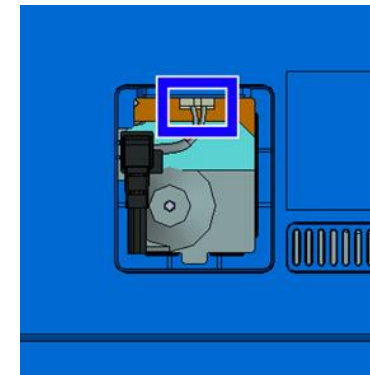

1-1. XBR-55X850C/855C/857C

1-1-4. REAR COVER (L HRN) A



1

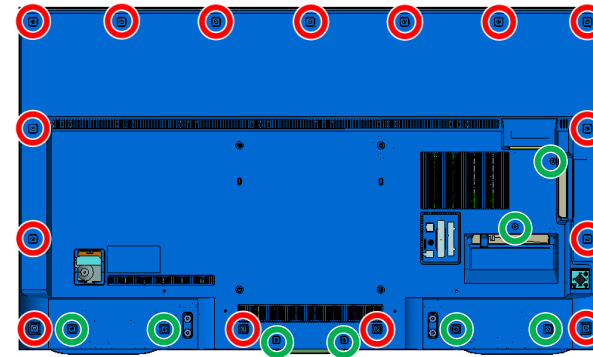

- 15 screws (SCREW , +PWH M3X6) P/N: 4-452-935-11
- 8 screws (SCREW, +BVTP 4X12 TYPE2 IT-3) P/N: 2-580-639-01

2

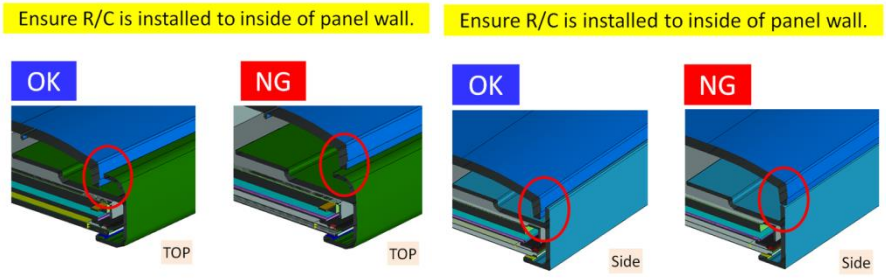
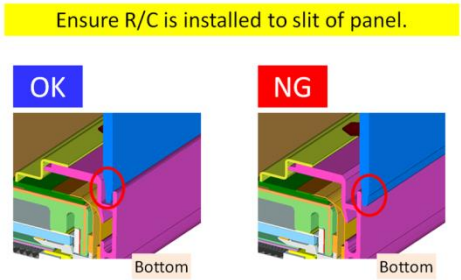

3

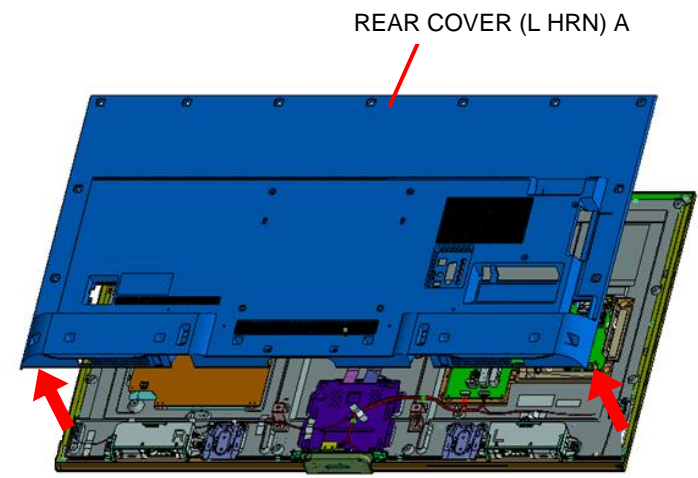

1-1. XBR-55X850C/855C/857C

1-1-5. TAPE AND WIRE DRESSING

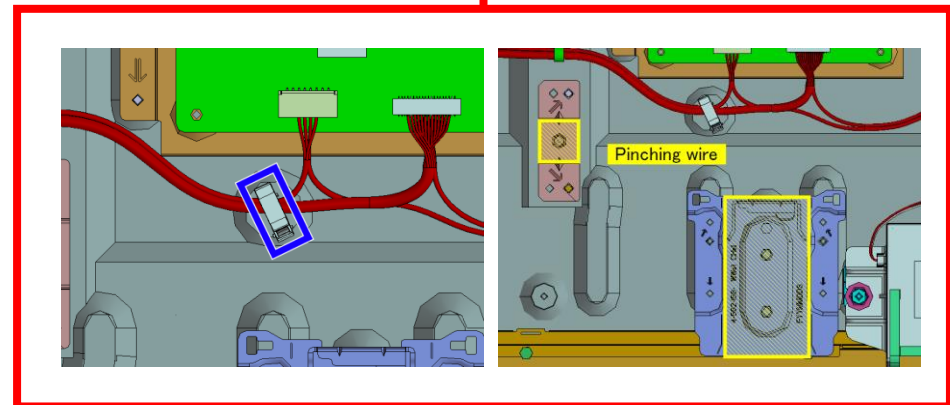
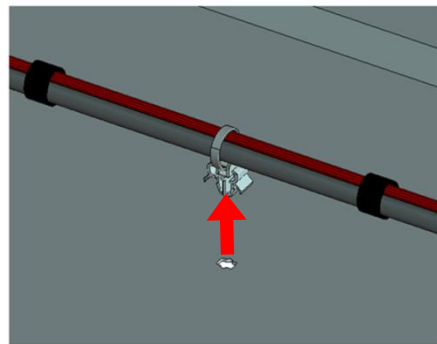
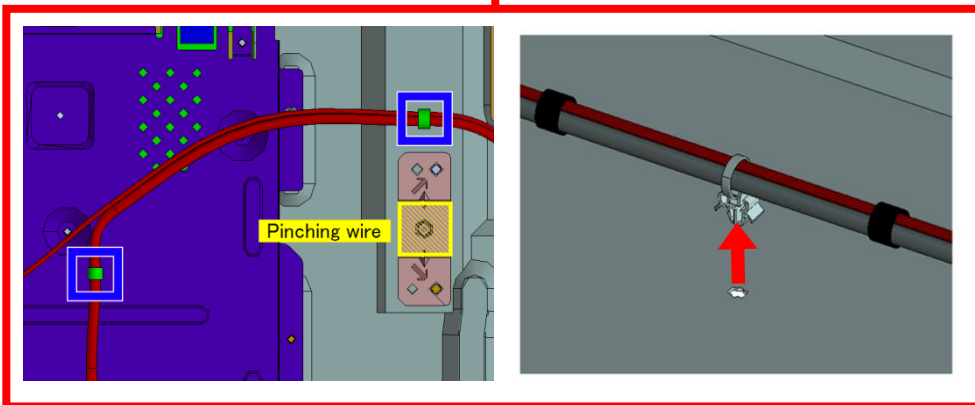
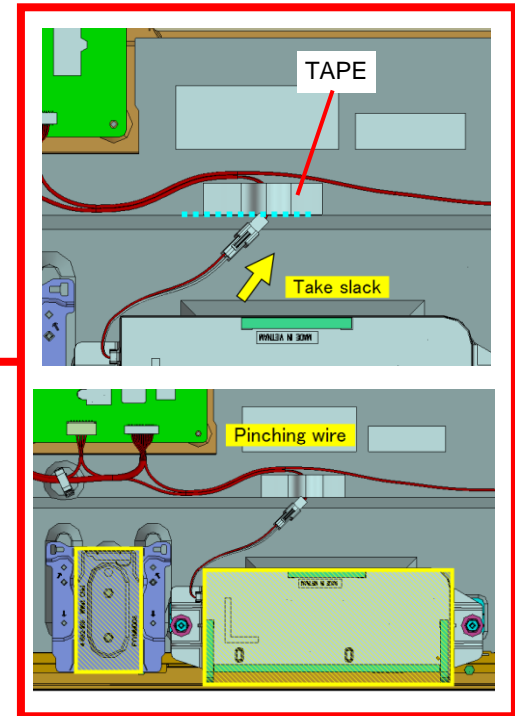
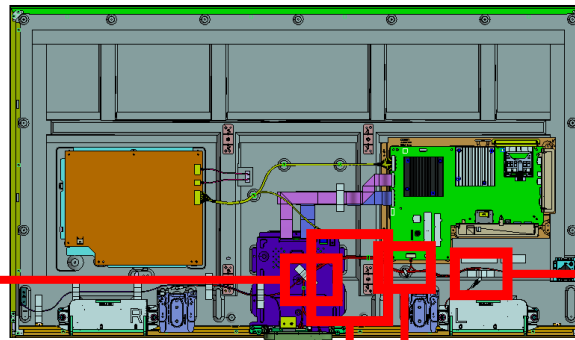
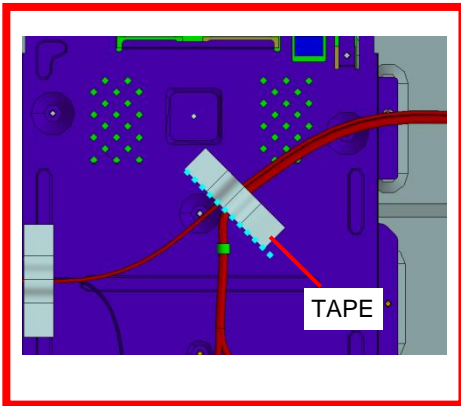

1-1. XBR-55X850C/855C/857C

1-1-6. TAPE AND WIRE DRESSING

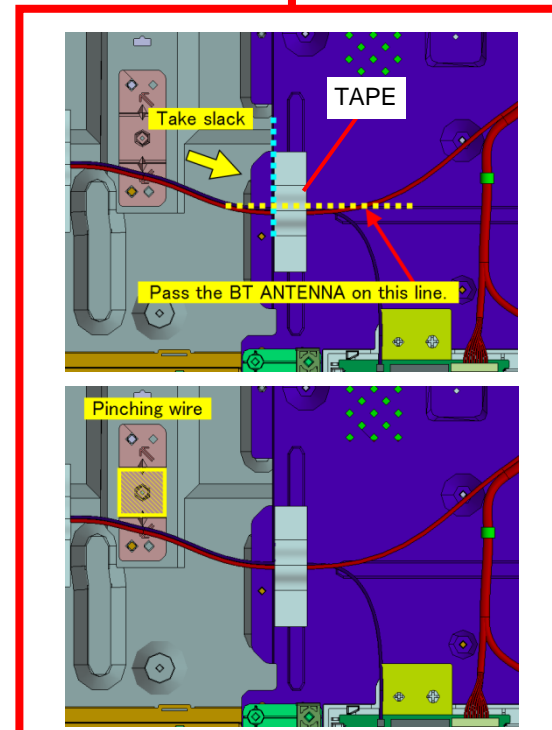
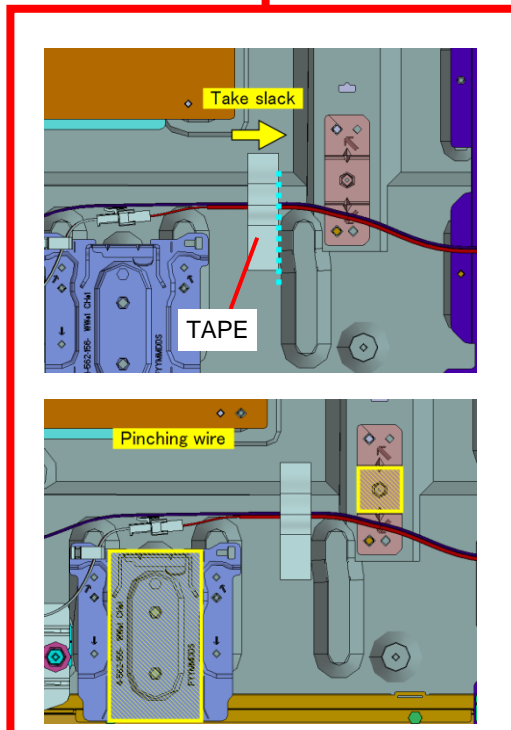
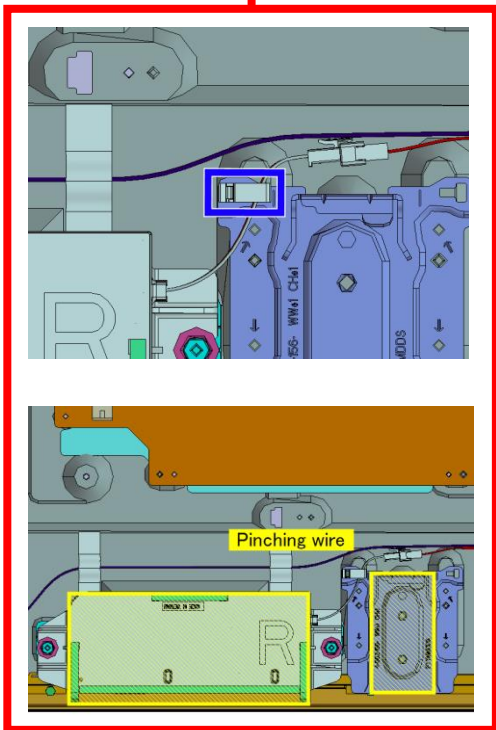
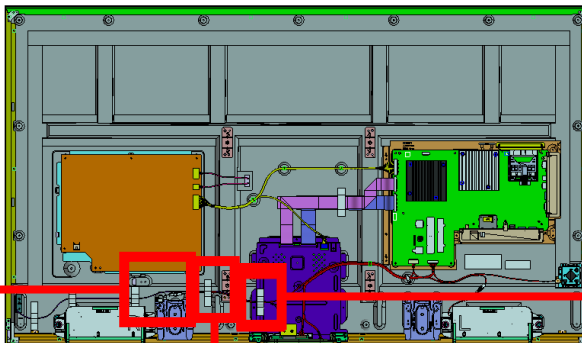

1-1. XBR-55X850C/855C/857C

1-1-7. SPEAKER BOX ASSY (L)

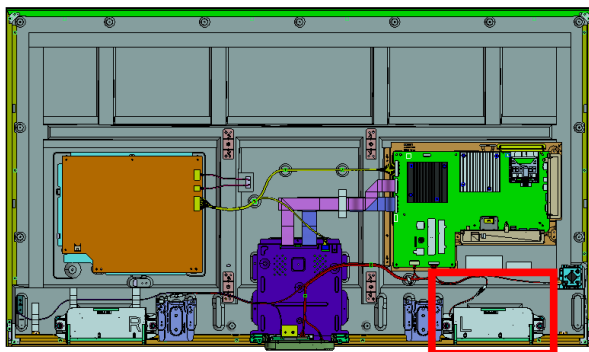

1

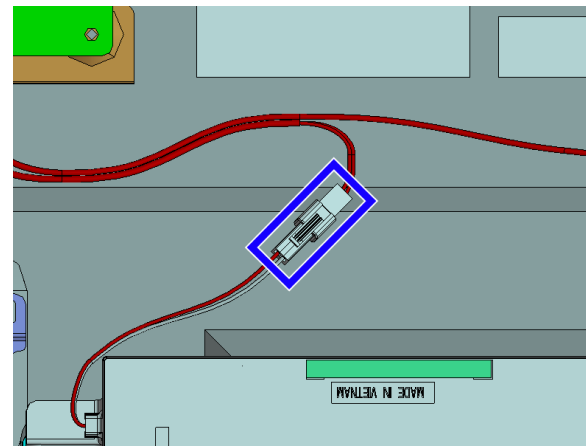

2

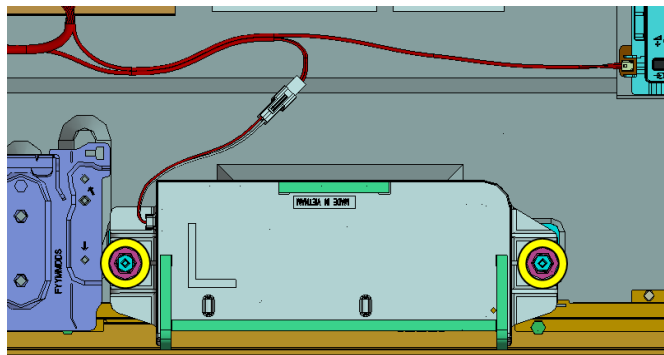

Don't pinch the wire

3

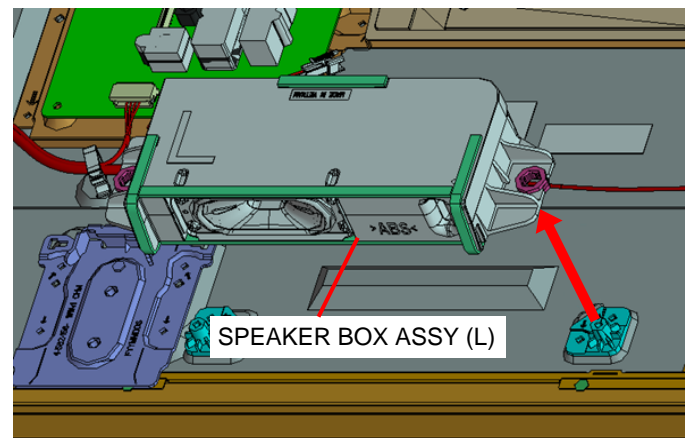

1-1. XBR-55X850C/855C/857C

1-1-8. SPEAKER BOX ASSY (R)

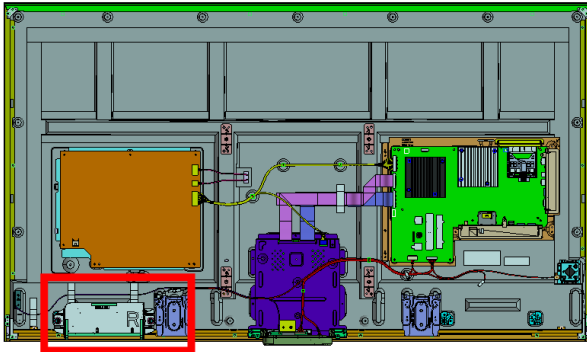

1

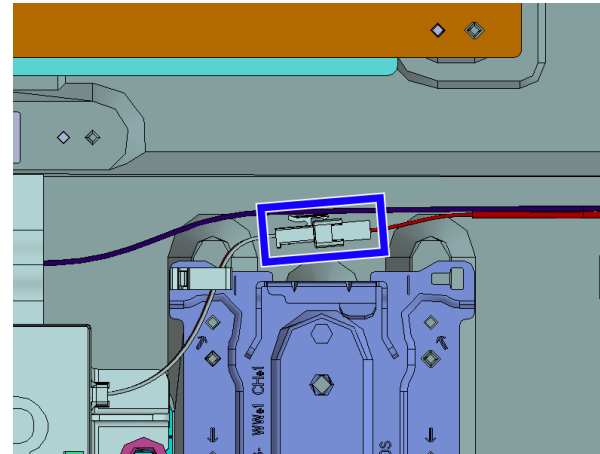

2

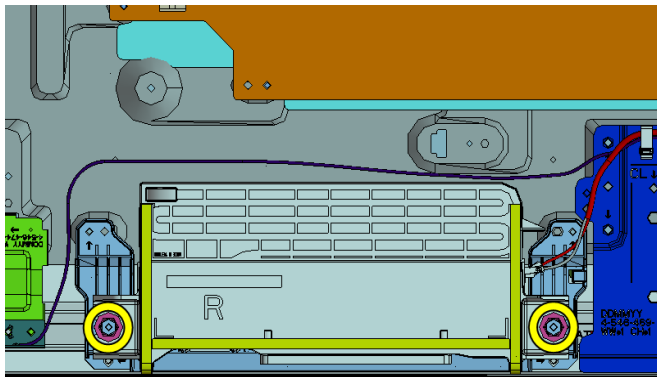

3

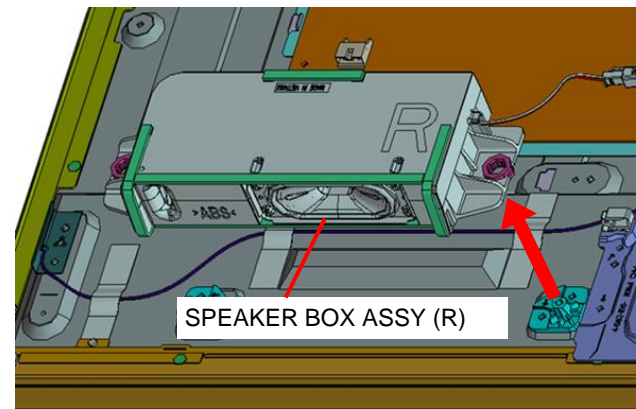

1-1. XBR-55X850C/855C/857C

1-1-9. TAPE

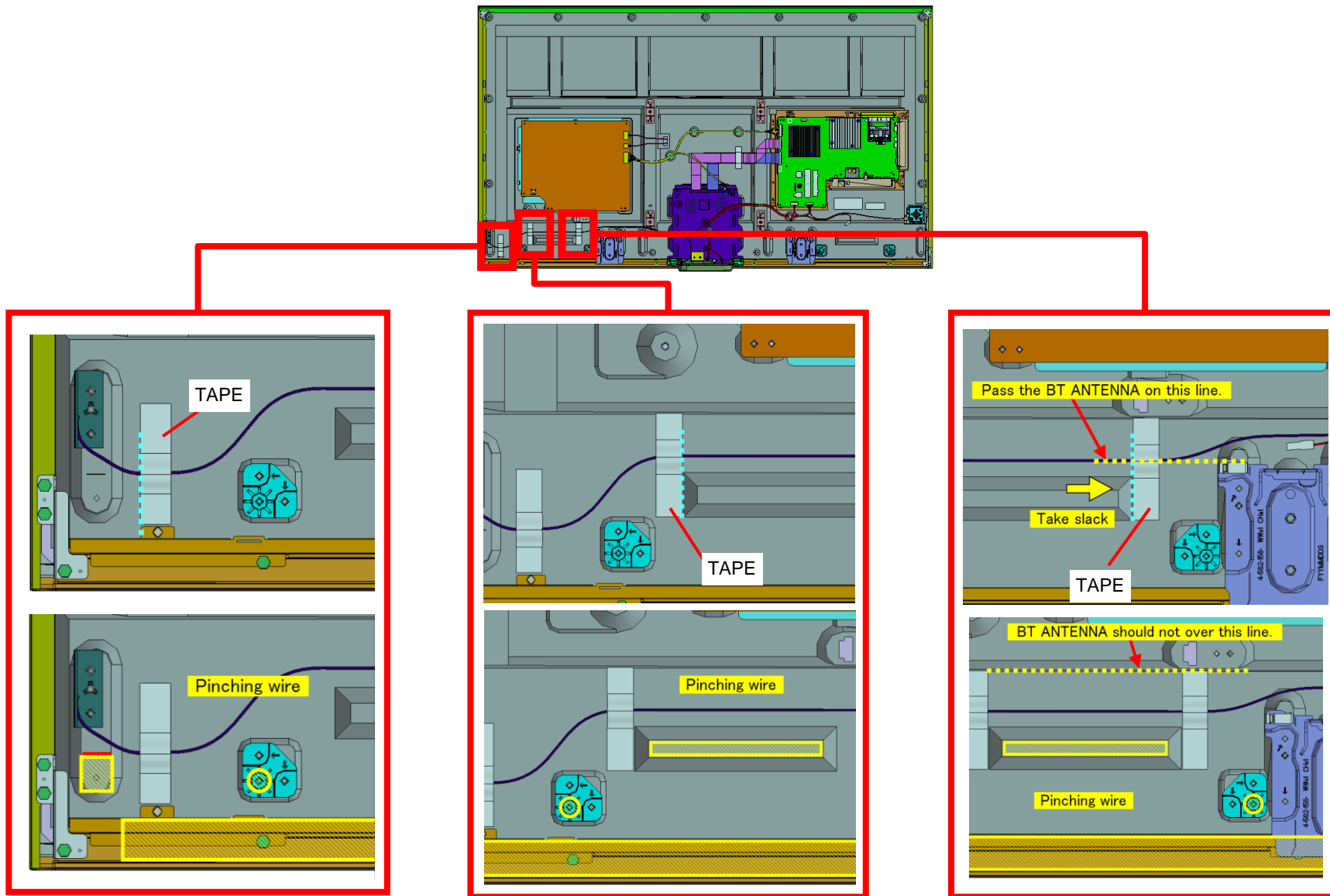

1-1. XBR-55X850C/855C/857C
1-1-10. BT ANTENNA/WIFI ANTENNA

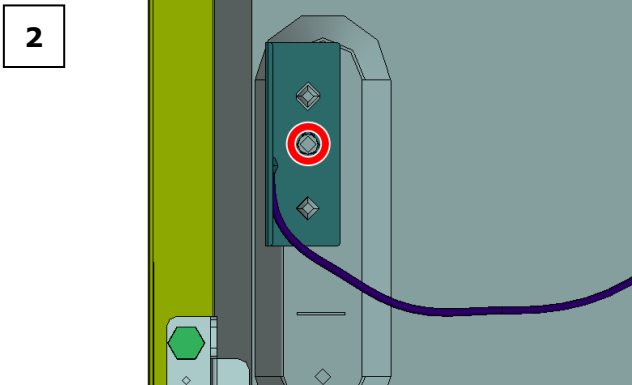
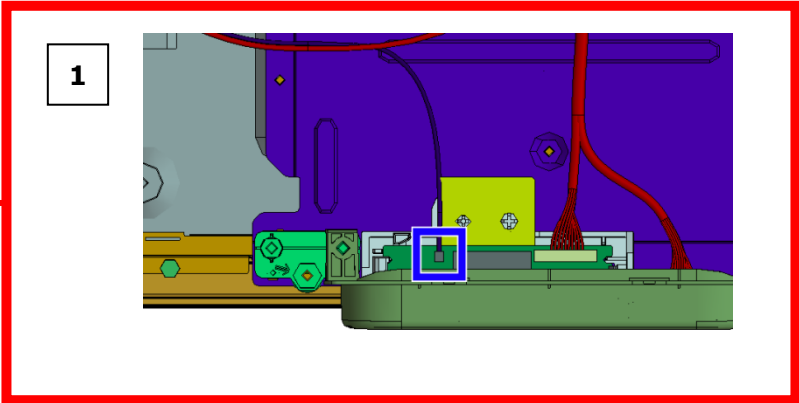
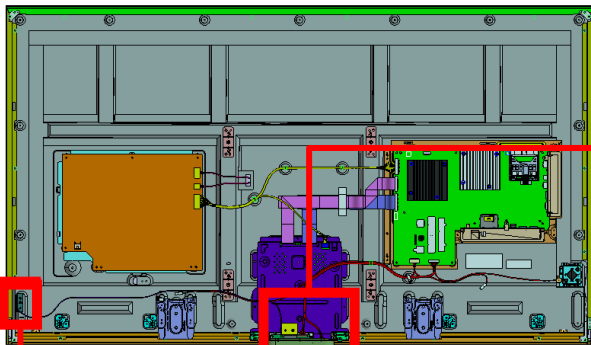

Screw (SCREW (+PSW))(M3X6)
P/N: 2-990-421-41

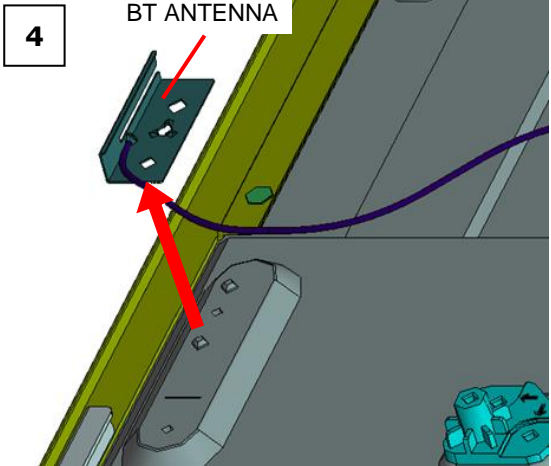
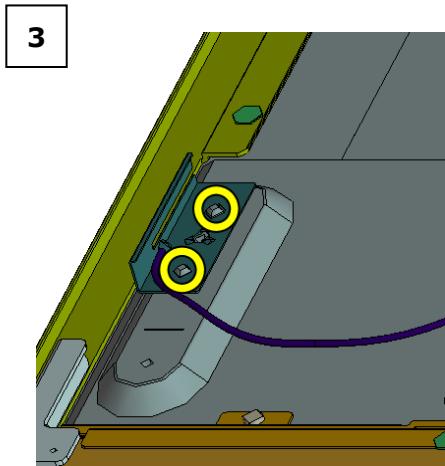

1-1. XBR-55X850C/855C/857C

1-1-11. SMART CORE

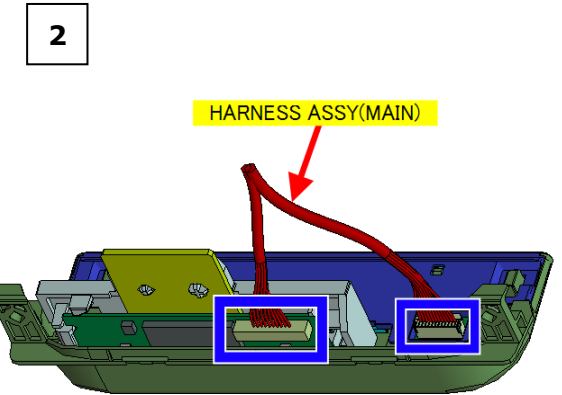
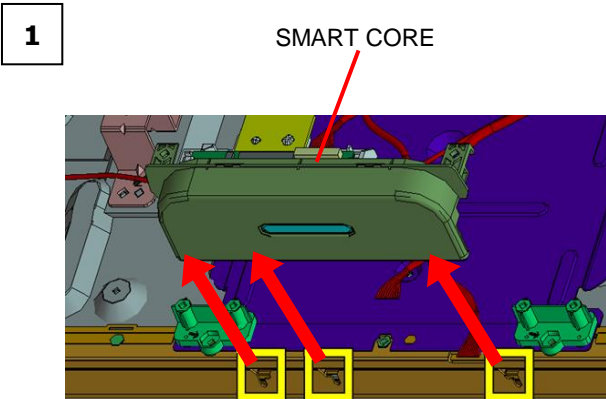
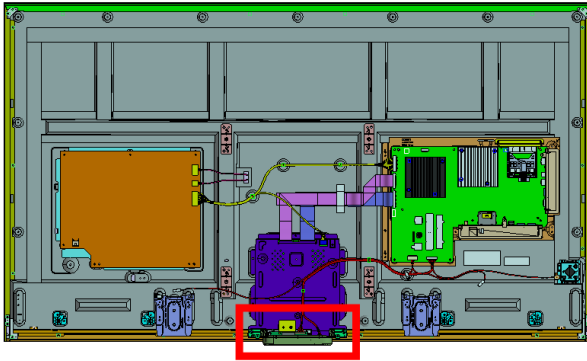

Notes on assembling the Smart core

Don't scratch O/P with Bezel while installing.

No gap between Smart Core and AL Bezel.

Don't touch these components while installing.

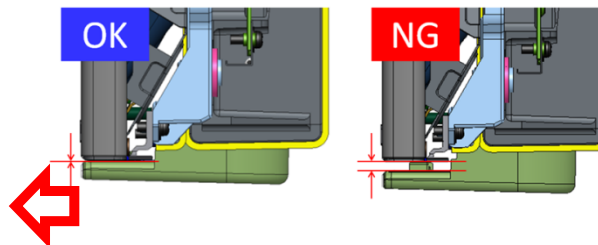
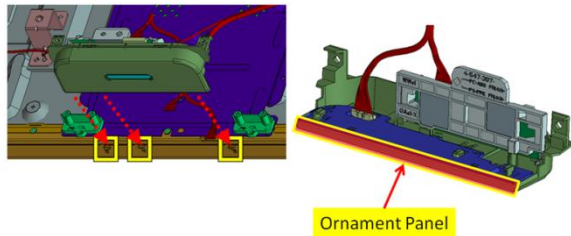

Front View of the TV

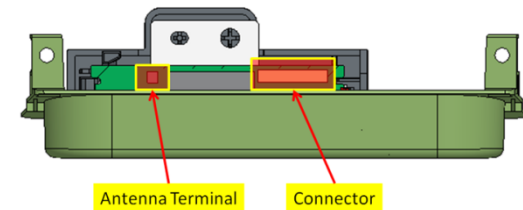

1-1. XBR-55X850C/855C/857C

1-1-12. SWITCH UNIT

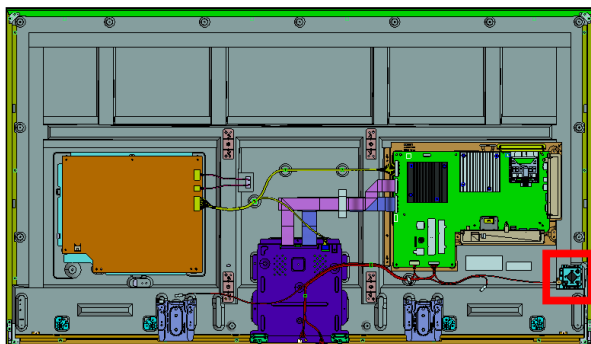

1

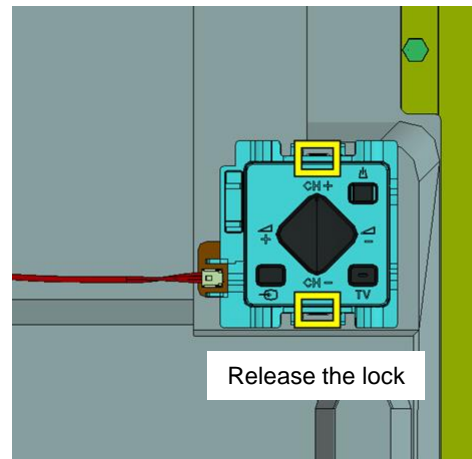

2

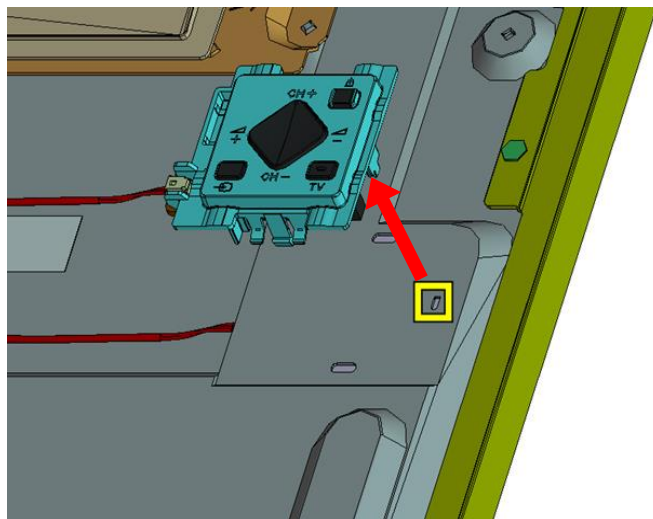

3

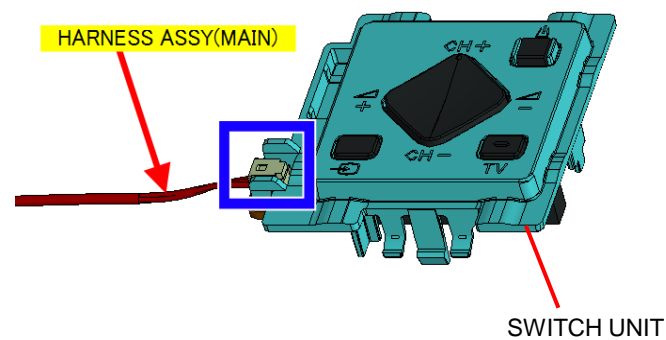

1-1. XBR-55X850C/855C/857C

1-1-13. HARNESS ASSY (MAIN) AND CONNECTOR ASSY 28P

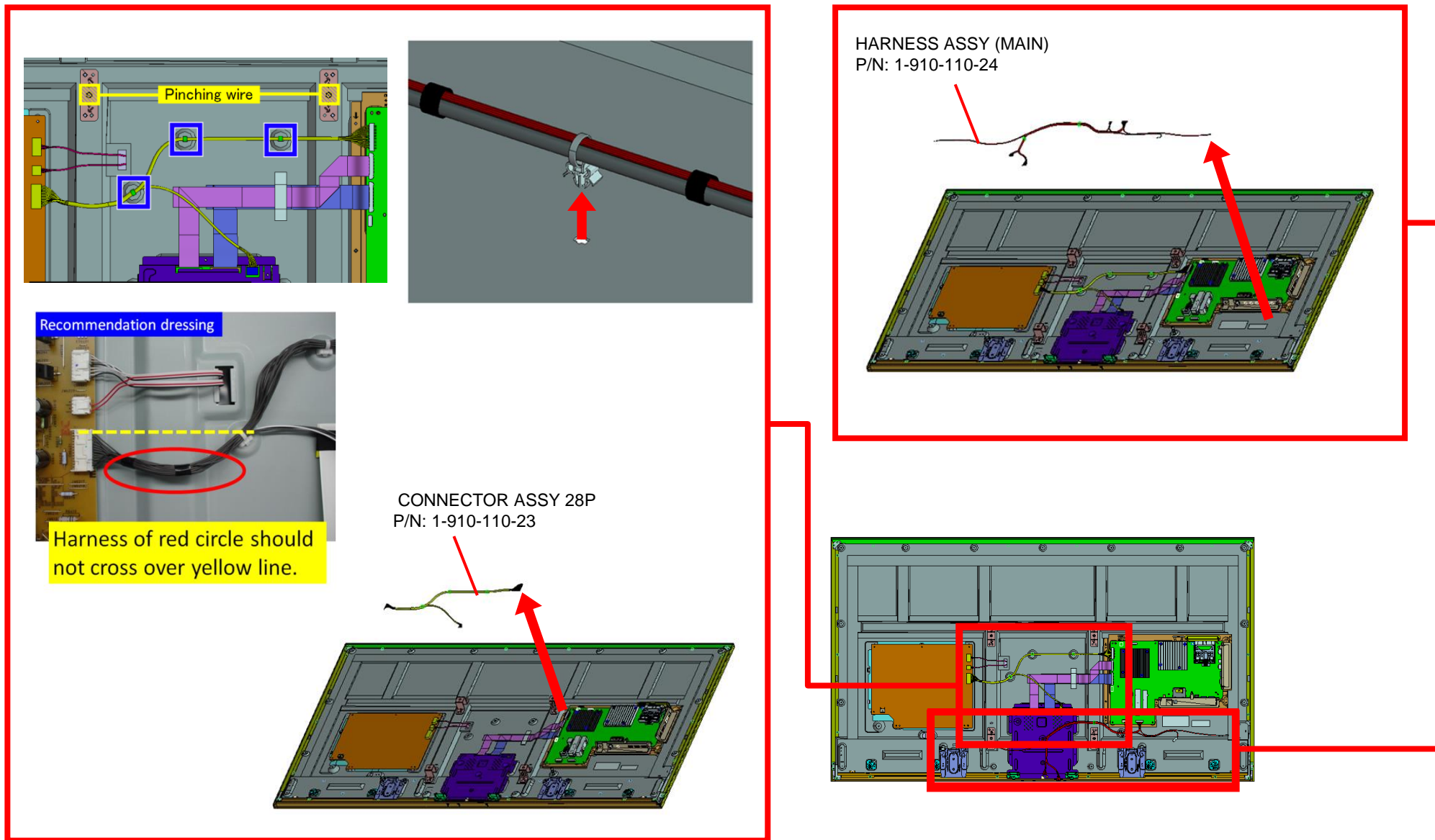

1-1. XBR-55X850C/855C/857C

1-1-14. BRACKET,VESA(HWK)

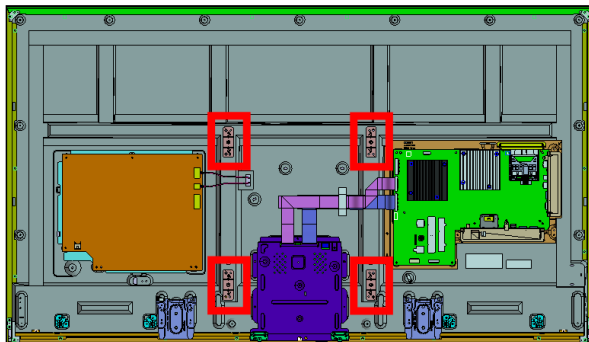

1

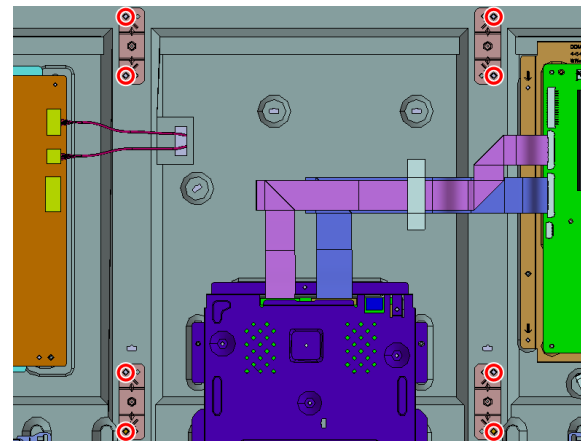

8 screws (SCREW, +PSW M4X8) P/N: 2-580-600-11

2

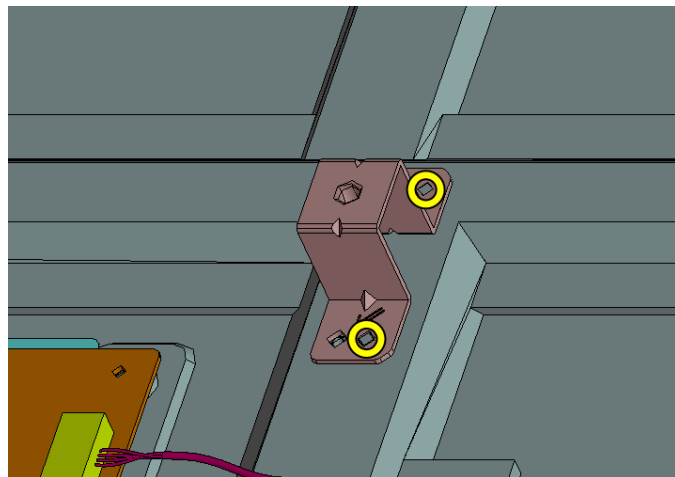

3

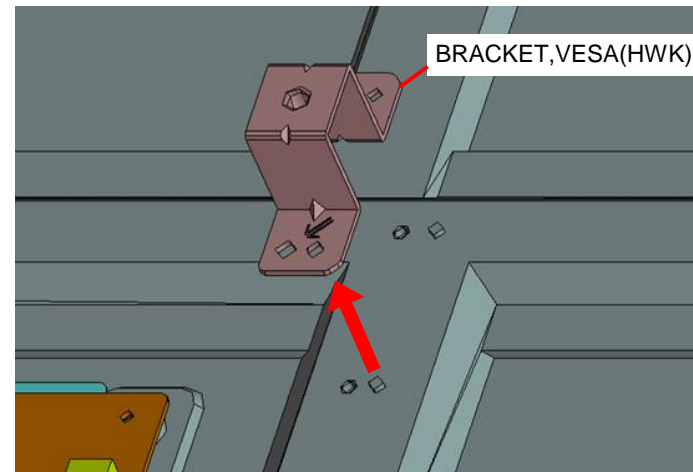

1-1. XBR-55X850C/855C/857C

1-1-15. BRACKET, SC(HWK)

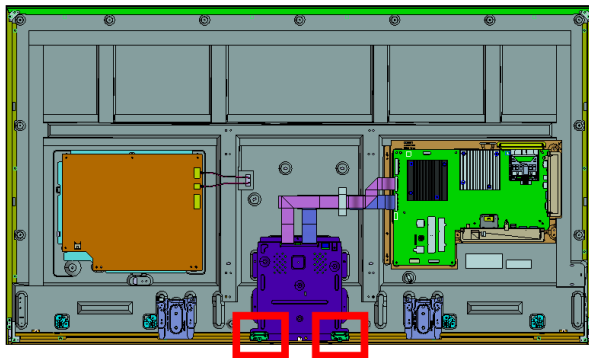

1

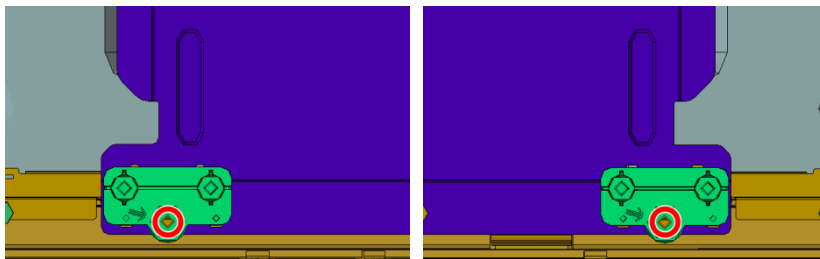

Confirm BRACKET,SC is installed to hole surely before screwing.

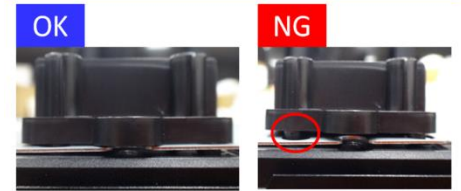

8 screws (SCREW, (+PSW)(M3X6)) P/N: 2-990-421-41

2

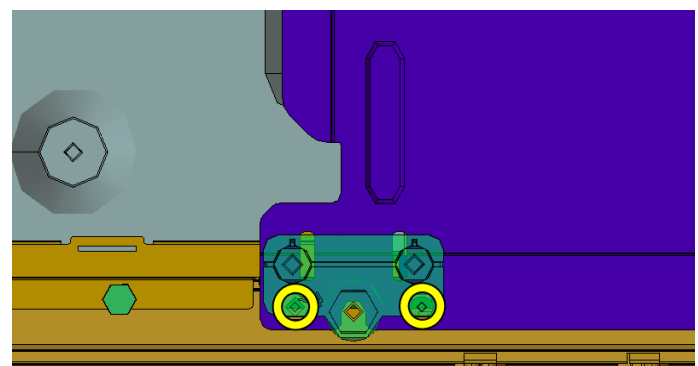

3

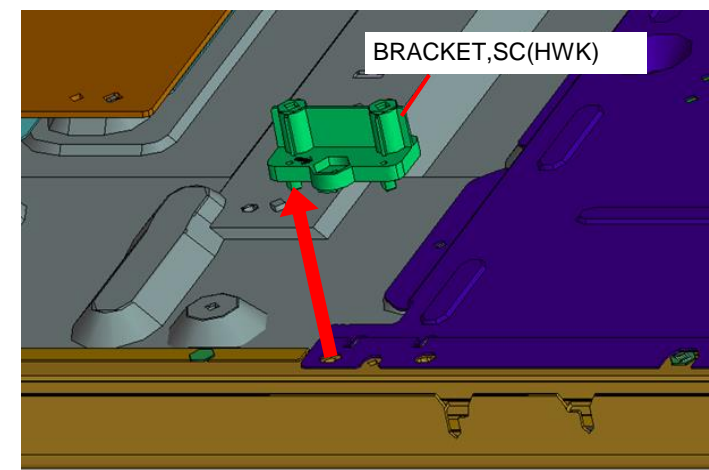

1-1. XBR-55X850C/855C/857C

1-1-16. SLIDE, CLAMP

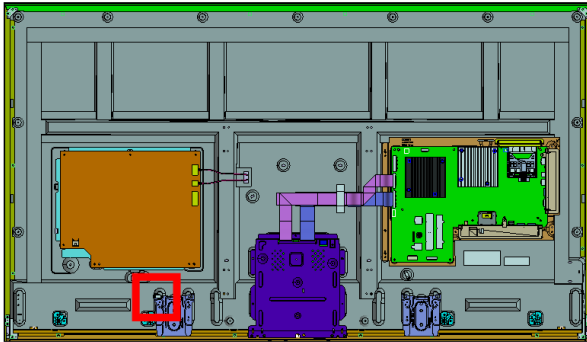

1

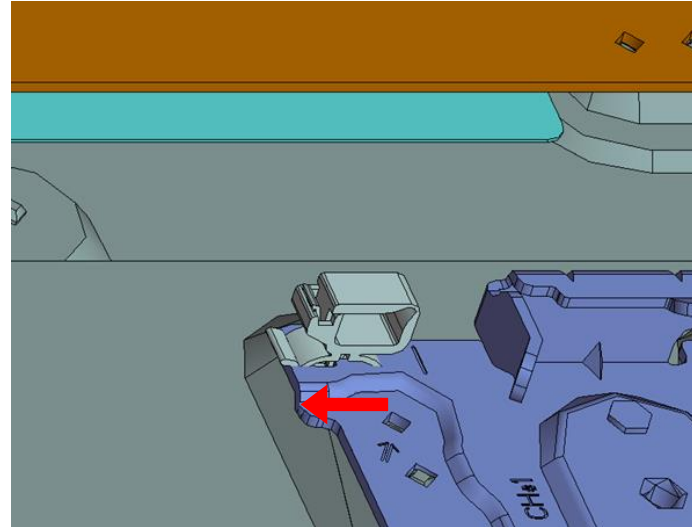

2

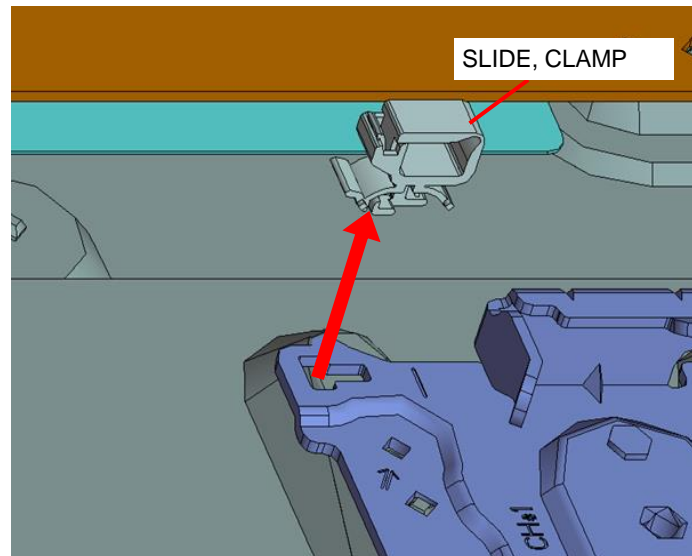

1-1. XBR-55X850C/855C/857C

1-1-17. BOTTOM, FRAME (HRN)

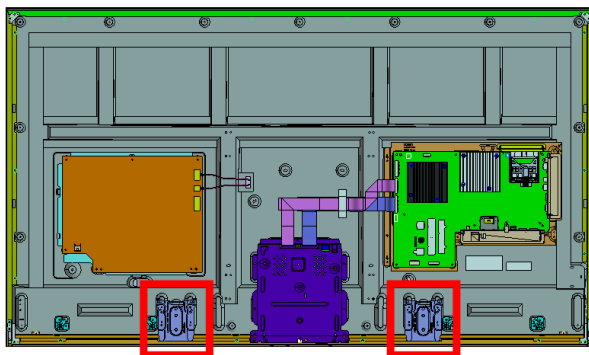

1

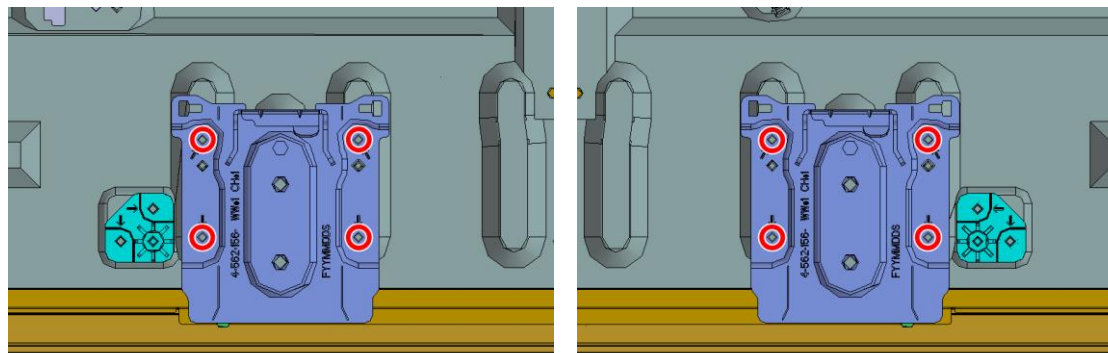

8 screws (SCREW, (+PSW)(M3X6)) P/N: 2-990-421-41

2

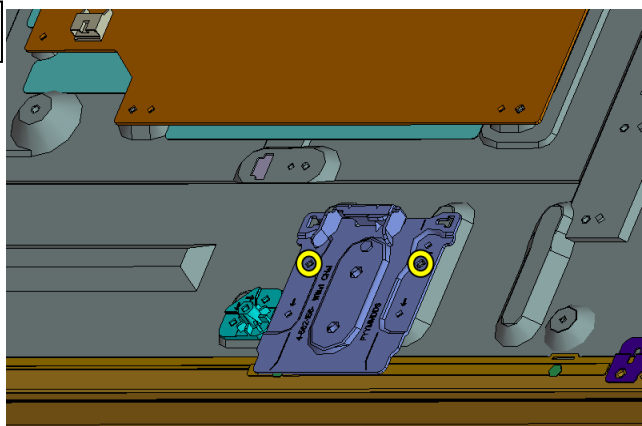

3

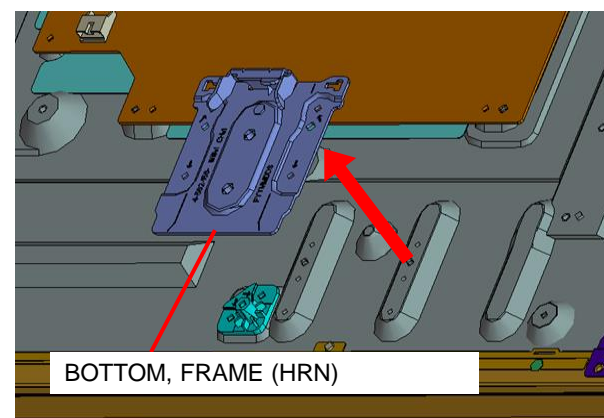

BOTTOM, FRAME (HRN)

1-1. XBR-55X850C/855C/857C

1-1-18. BRACKET, SP (LAK)

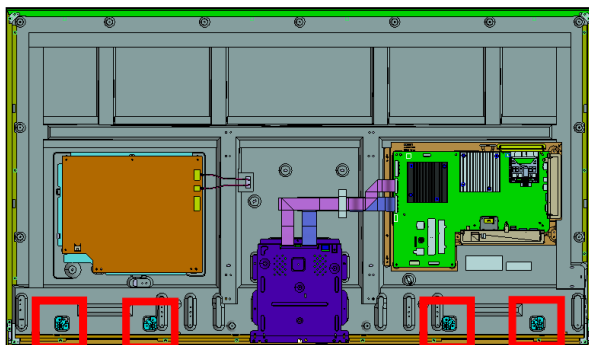

1

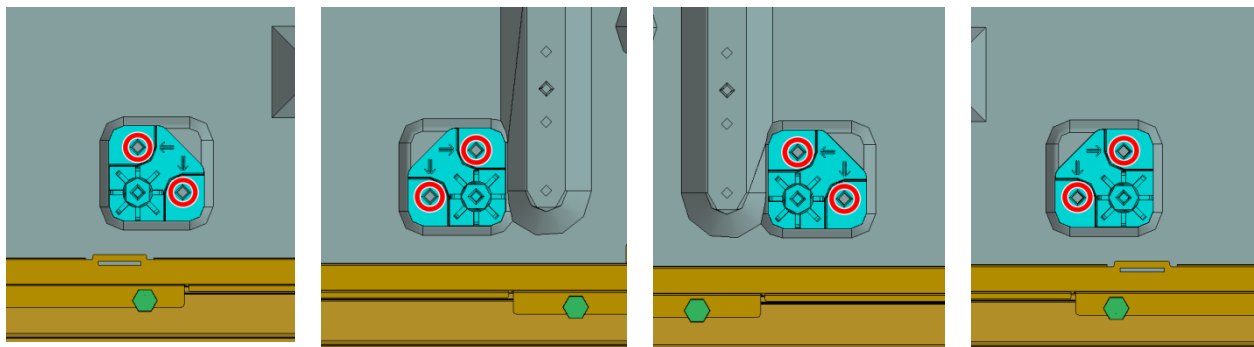

8 screws (SCREW, (+PSW)(M3X6)) P/N: 2-990-421-41

2

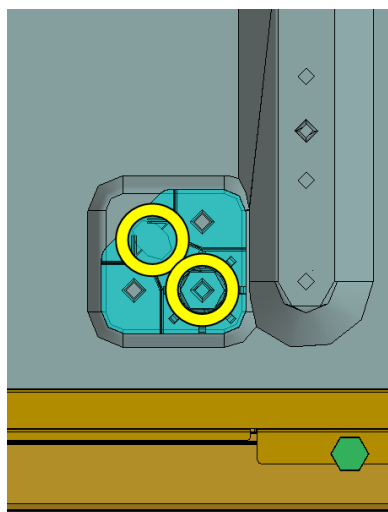
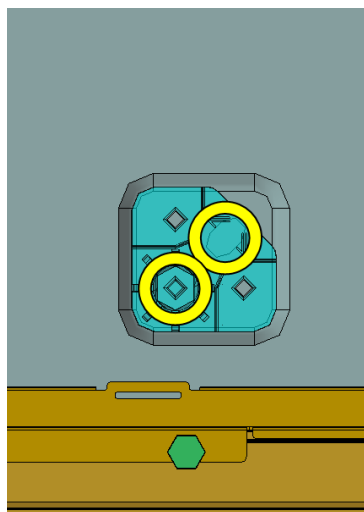

3

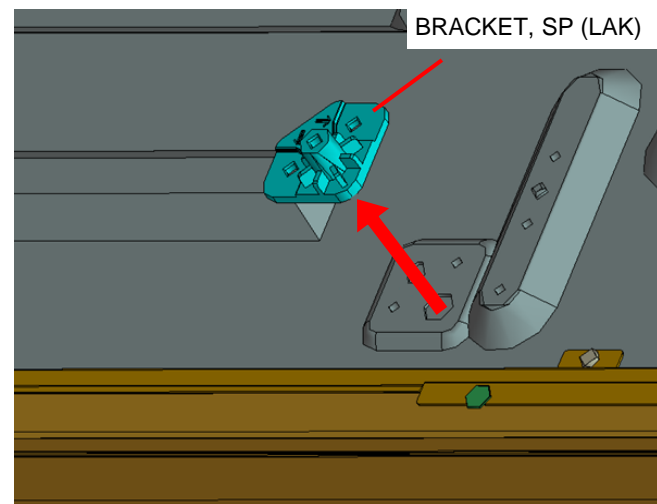

1-1. XBR-55X850C/855C/857C

1-1-19. GL3(CH)-STATIC CONVERTER(TV)

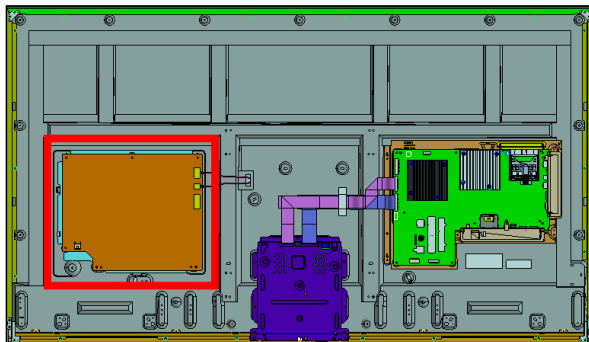

1

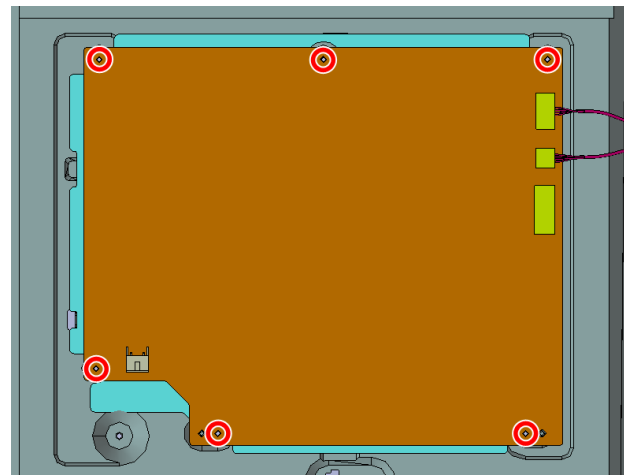

6 screws (SCREW, +PSW M3X6 W12) P/N: 4-256-393-11

2

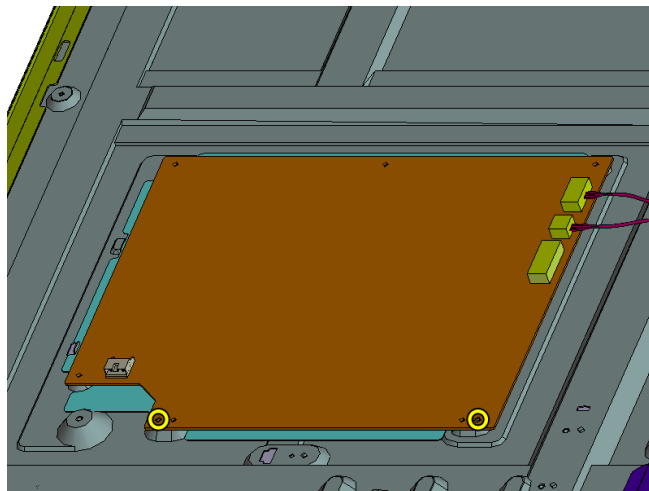

3

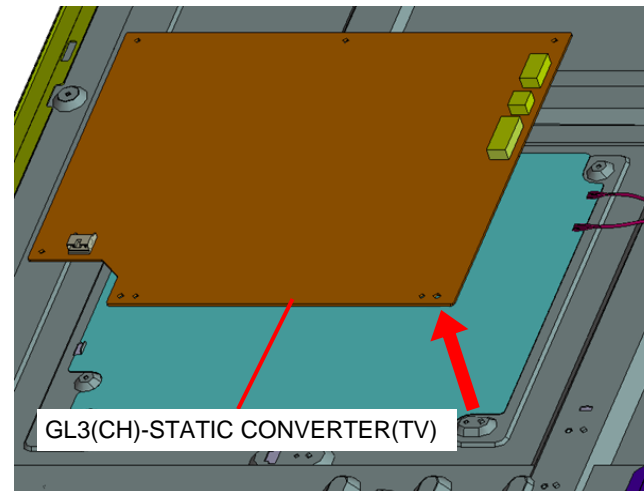

1-1. XBR-55X850C/855C/857C

1-1-20. SHEET, INSULATION(HRN L)

(An insulation sheet is under the GL3 power supply board)

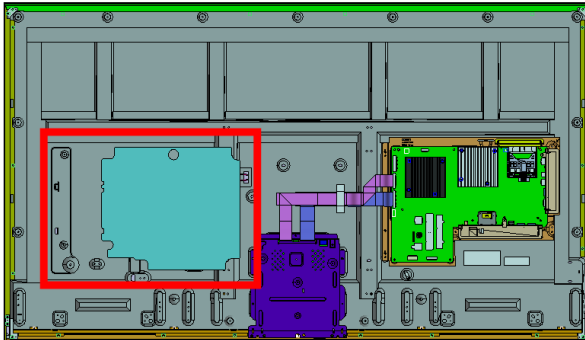

1

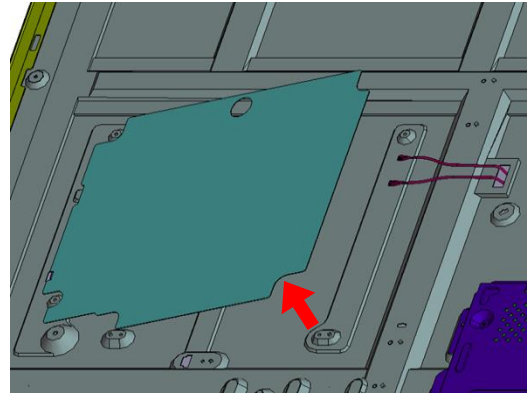

2

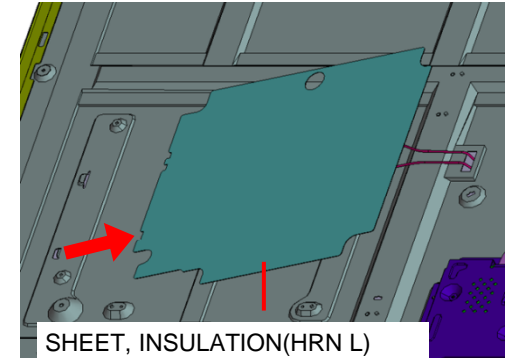

SHEET, INSULATION(HRN L)

Notes on assembling the Insulation sheet (HRN L)

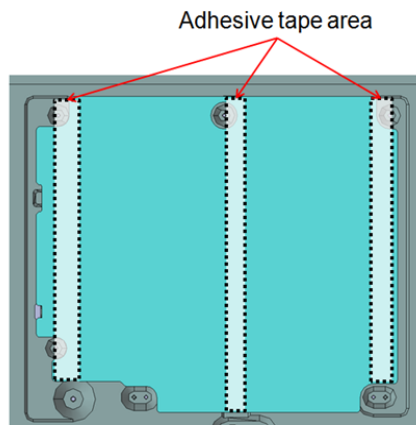

Caution

When handling,
 • Be sure not to touch adhesive tape area.
 After installing,
 • Be sure to push all of adhesive tape area to avoid peel off of "Sheet, Insulation".

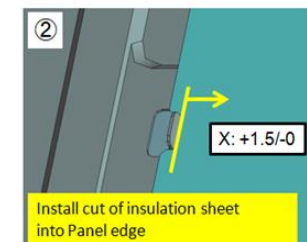
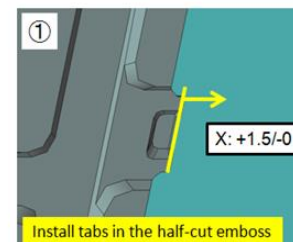
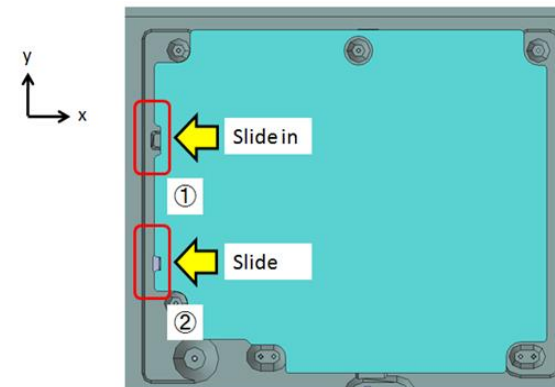

1-1. XBR-55X850C/855C/857C

1-1-21. FLEXIBLE FLAT CABLE 41P (XFS) AND FLEXIBLE FLAT CABLE 51P (XFS)

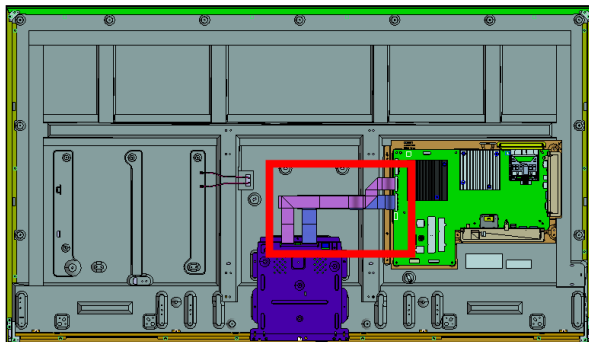

1

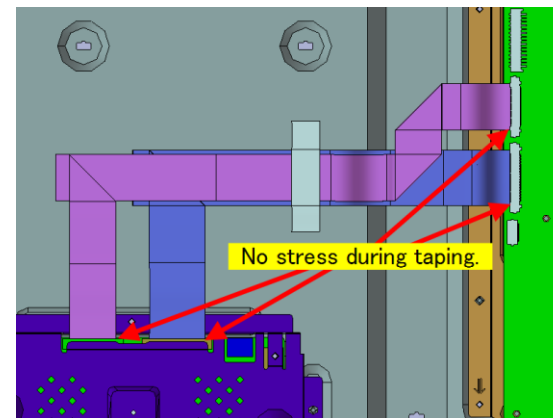
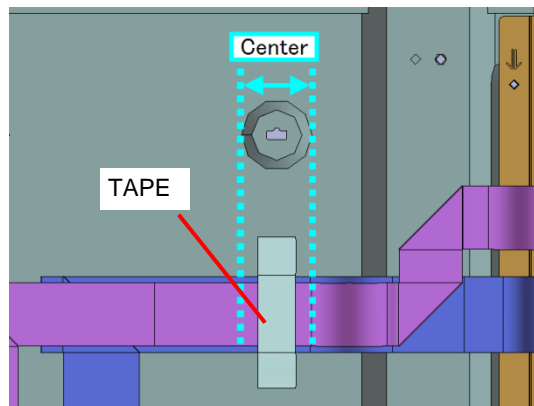

2

FLEXIBLE FLAT CABLE 41P (XFS)
 P/N: 1-848-915-11 (Except BR6)
 P/N: 1-848-927-11 (BR6)

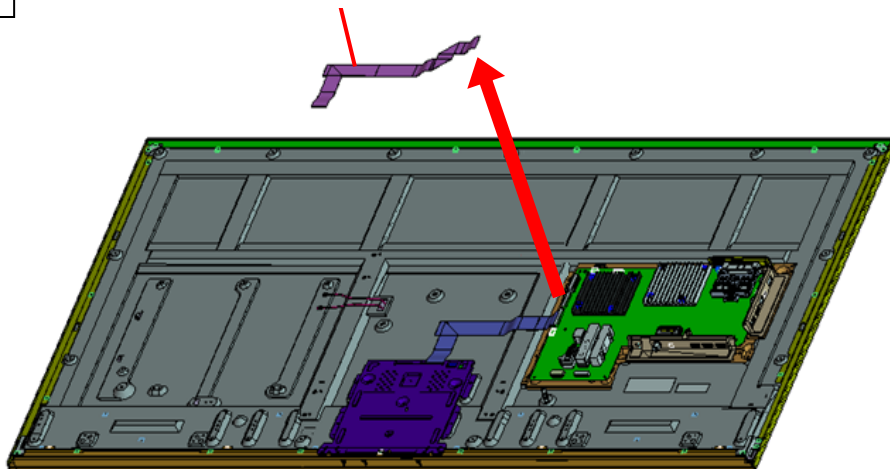

3

FLEXIBLE FLAT CABLE 51P (XFS)
 P/N: 1-848-914-11 (Except BR6)
 P/N: 1-848-922-11 (BR6)

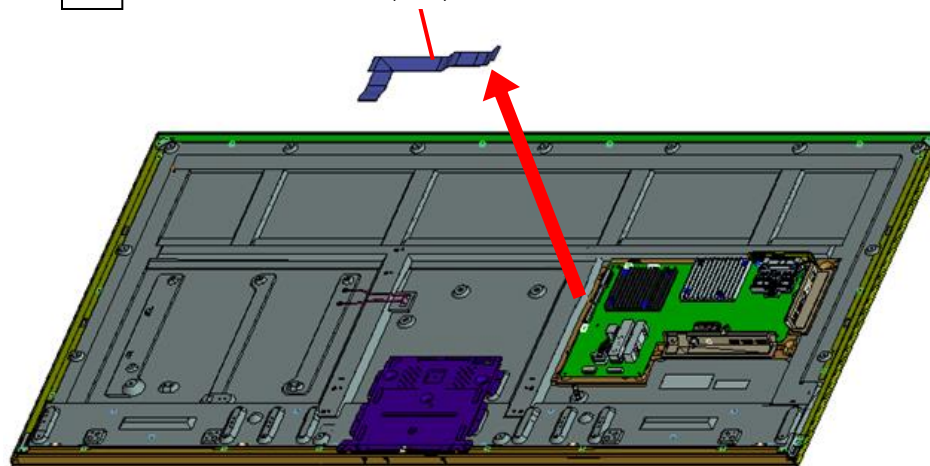

1-1. XBR-55X850C/855C/857C

1-1-22. BRACKET, UNDER FL (MOLD)

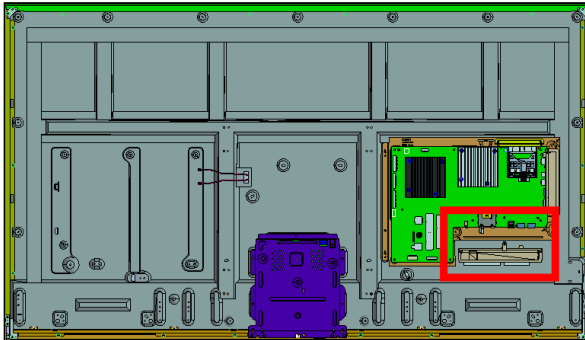

1

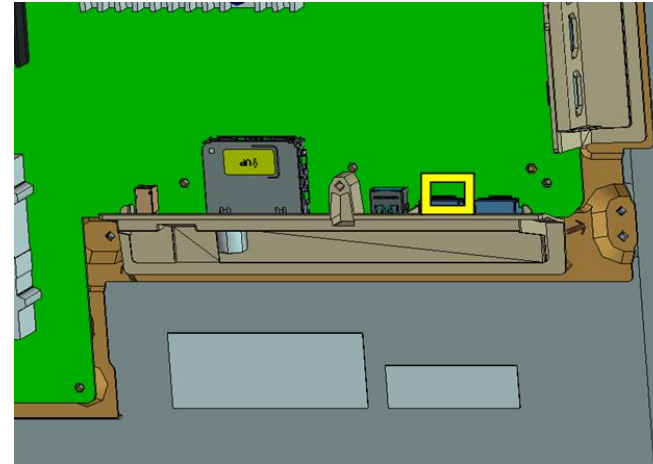

2

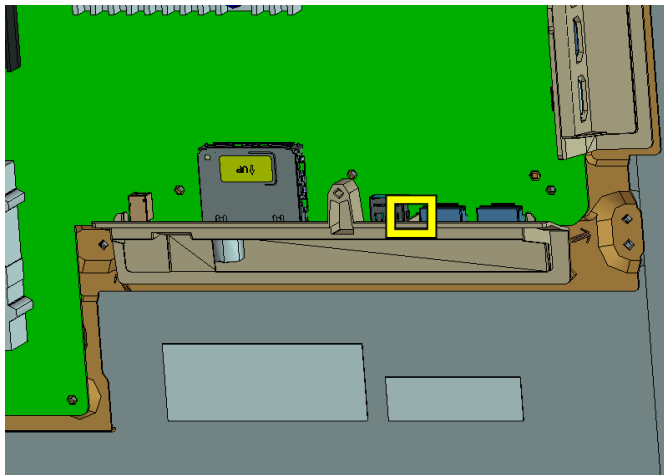

3

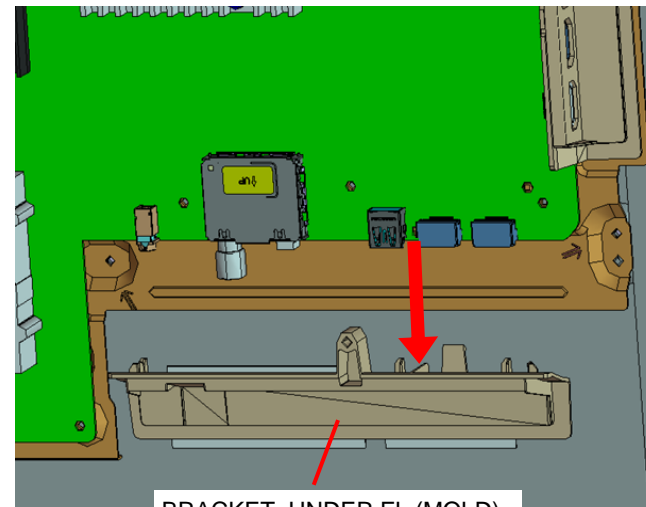

BRACKET, UNDER FL (MOLD)

1-1. XBR-55X850C/855C/857C

1-1-23. BRACKET, SIDE FL (MOLD)

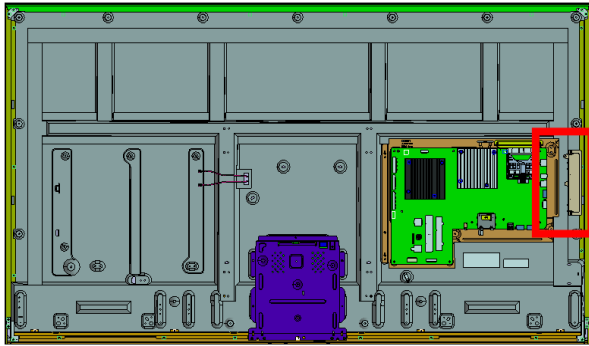

1

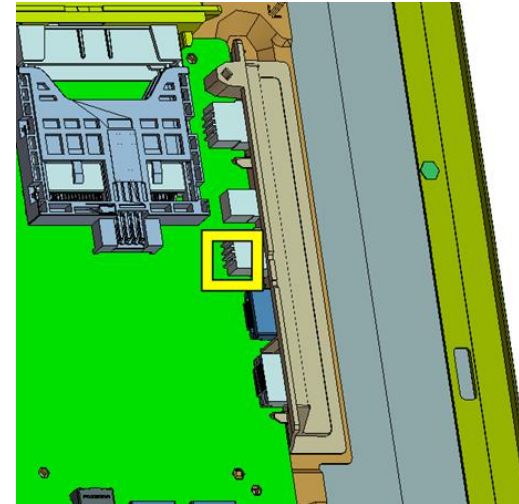

2

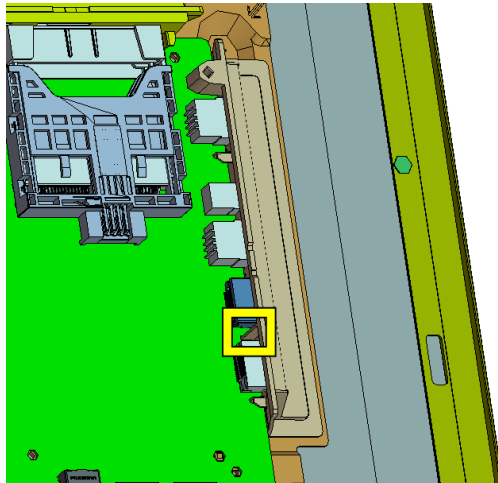

3

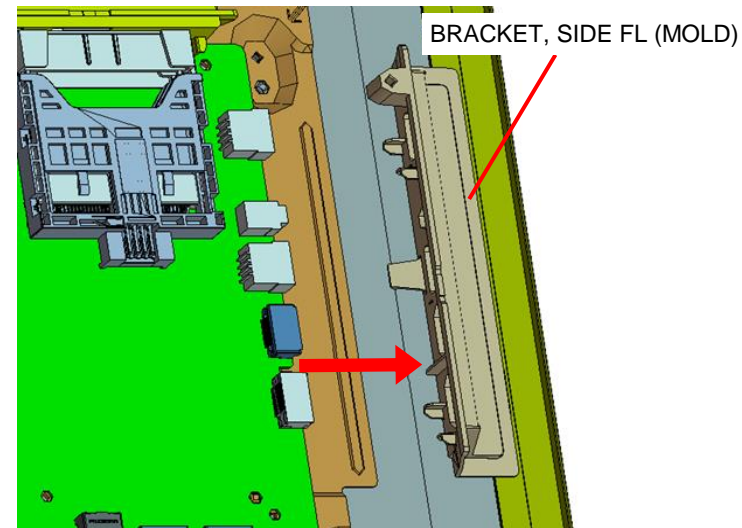

1-1. XBR-55X850C/855C/857C

1-1-24. BRACKET, TOP FL (MOLD)

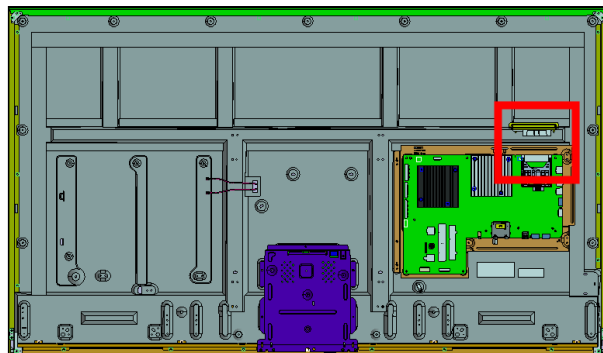

1

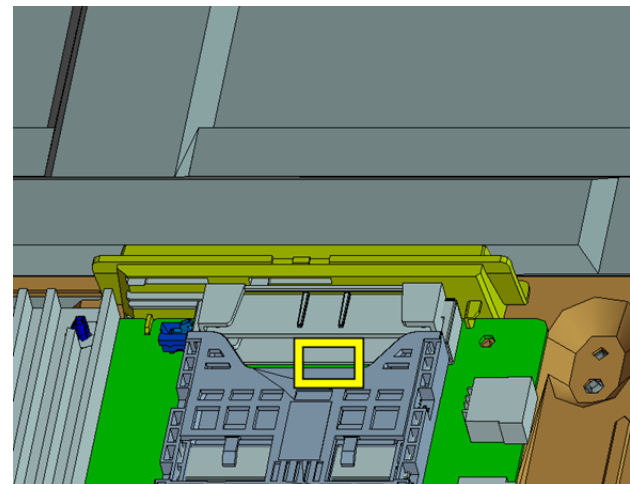

2

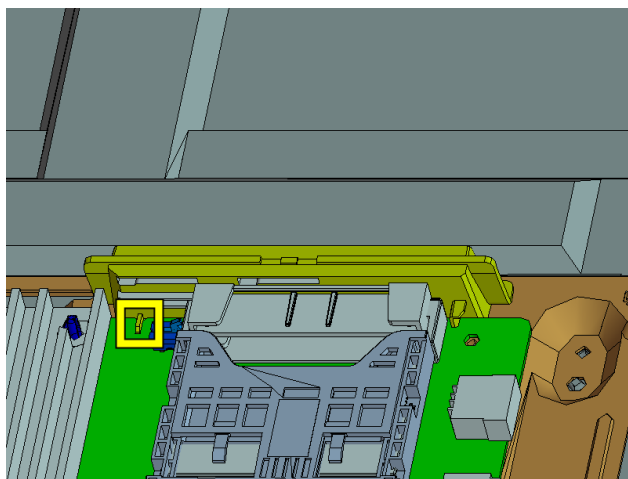

3

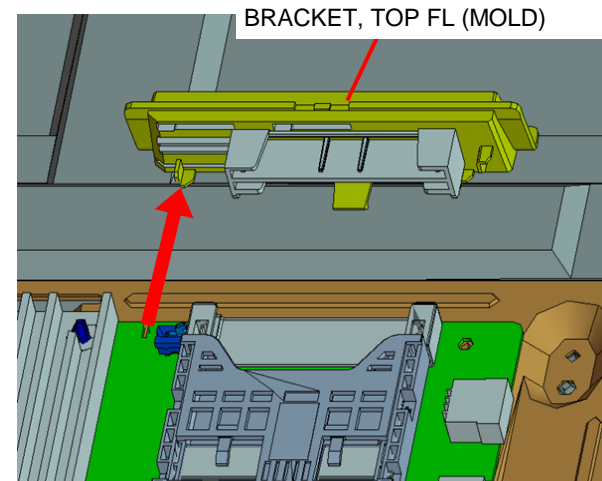

1-1. XBR-55X850C/855C/857C

1-1-25. PLATE, MAIN(HWK) ASSY

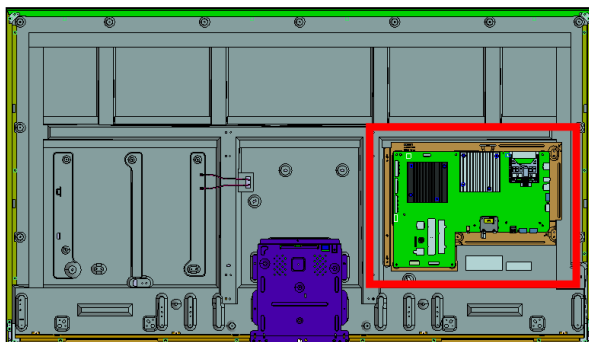

1

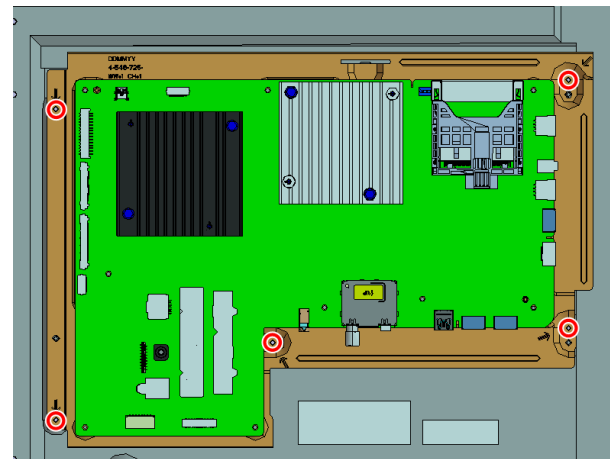

5 screws (SCREW, +PSW M3X8) P/N: 2-580-593-01

2

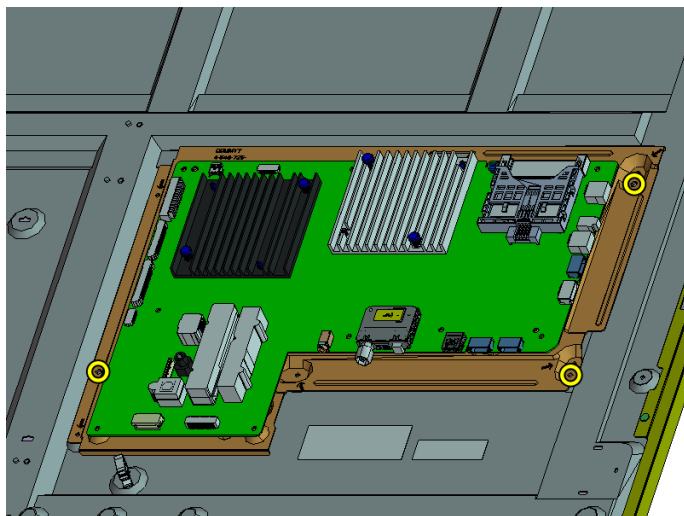

3

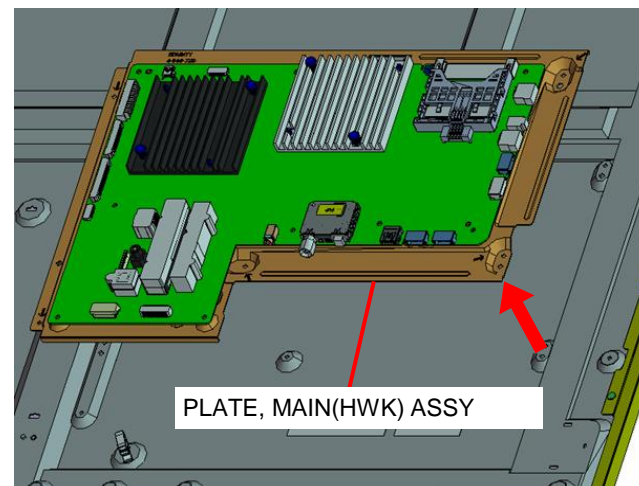

1-1. XBR-55X850C/855C/857C

1-1-26. BMFL ASSY

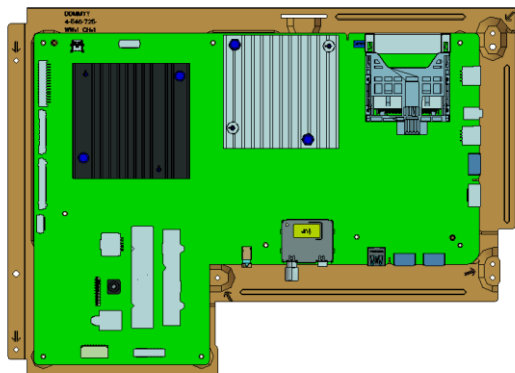

1

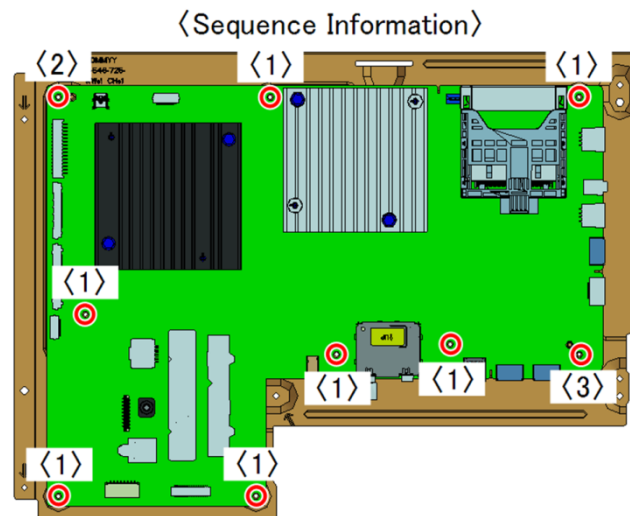

9 screws (SCREW (+PSW)(M3X6)) P/N: 2-990-421-41

2

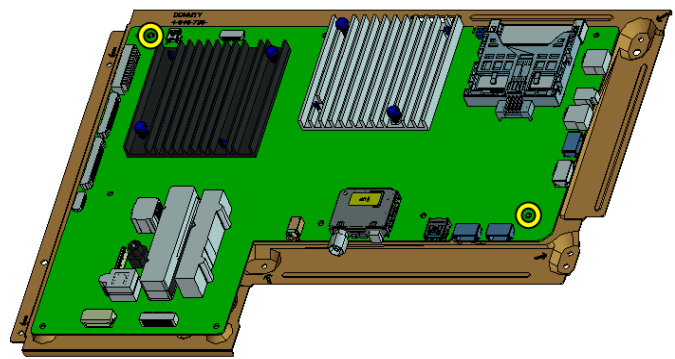

3

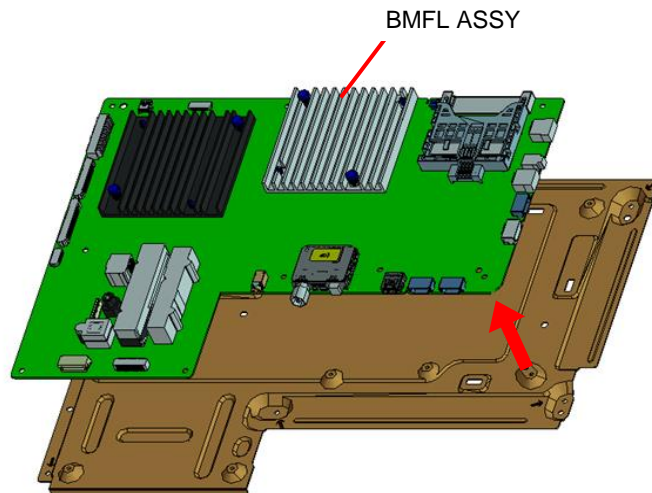

1-1. XBR-55X850C/855C/857C

1-1-27. GASKET (BMF)

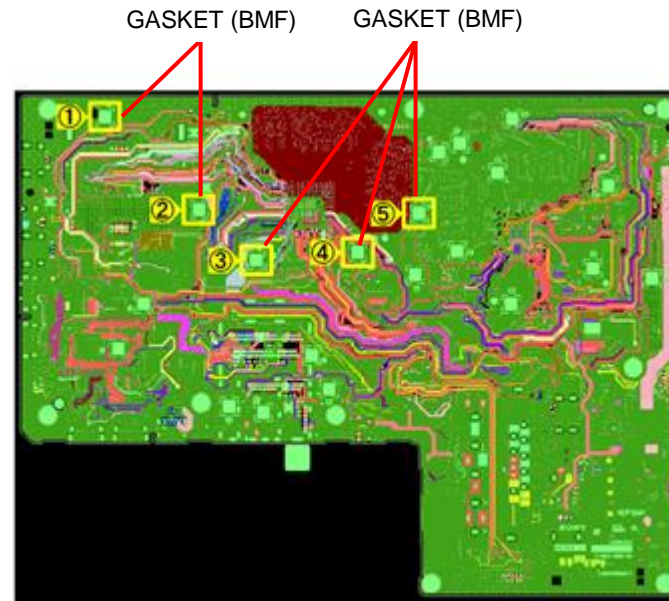
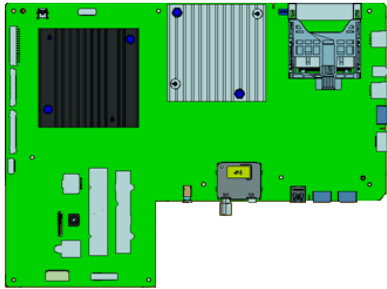

NOTE:

When you replace a BMFL board, it is necessary to stick five new GASKET on a new BMFL board.

GASKET (BMF): 4-566-117-01

Stick GASKET inside the guide line.

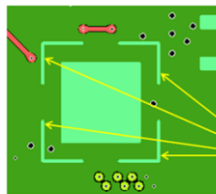

Guide line

*No indication of direction

To stick the GASKET firmly,

Press the gasket until compression completely.

(0.5-1.0kgf)



Caution:

1. Please aim at the center of square land.
2. Assy the gaskets just before B board panel installation.

1-1. XBR-55X850C/855C/857C

1-1-28. SHEET, THERMAL(BM) AND PLATE, MAIN(HWK)

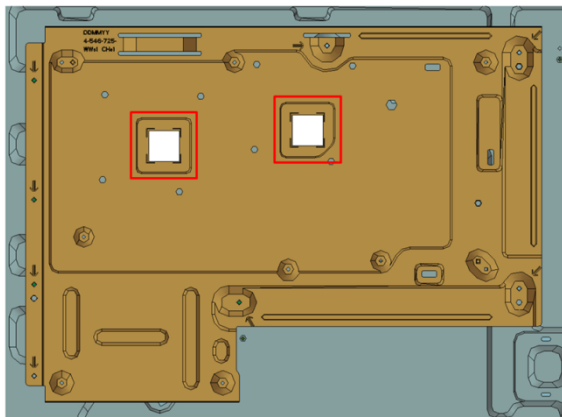

1

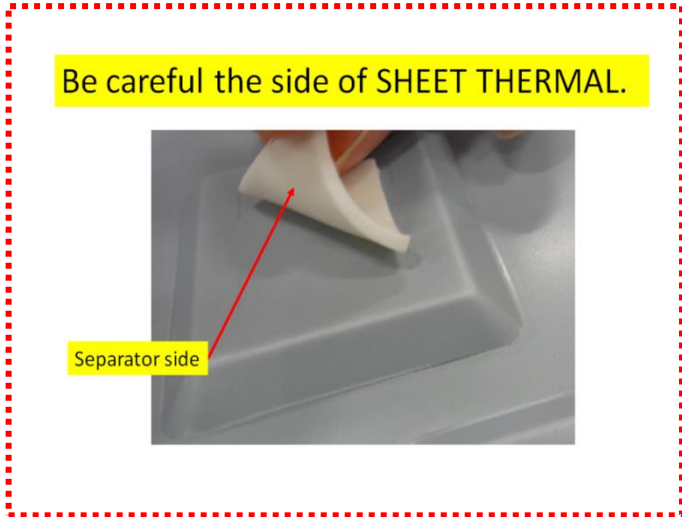
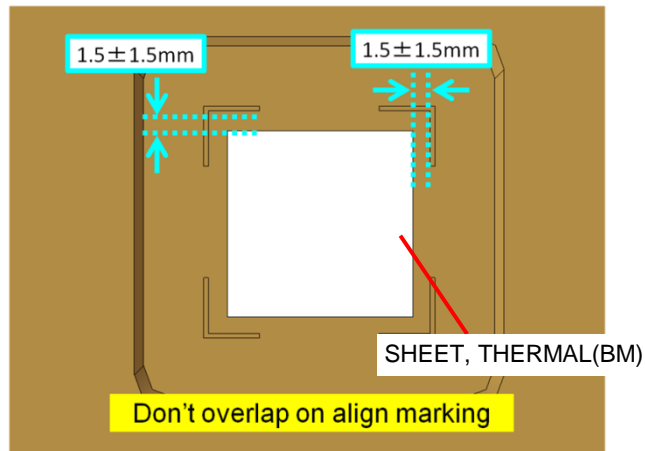

2

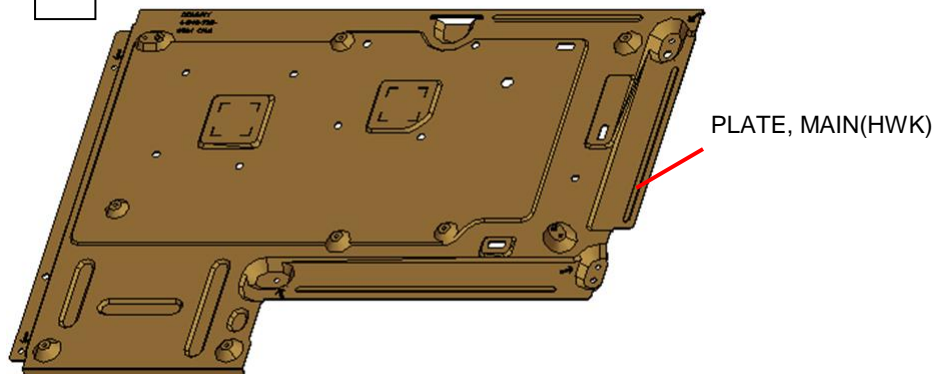

1-1. XBR-55X850C/855C/857C

1-1-29. SLIDE, CLAMP

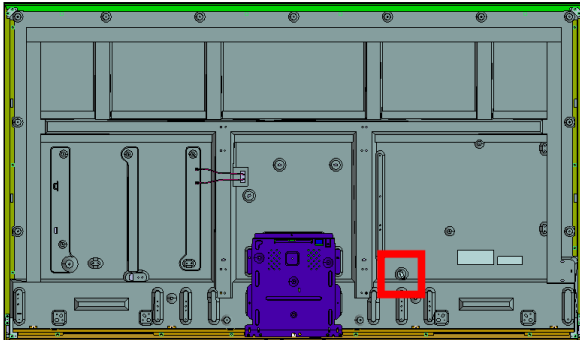

1

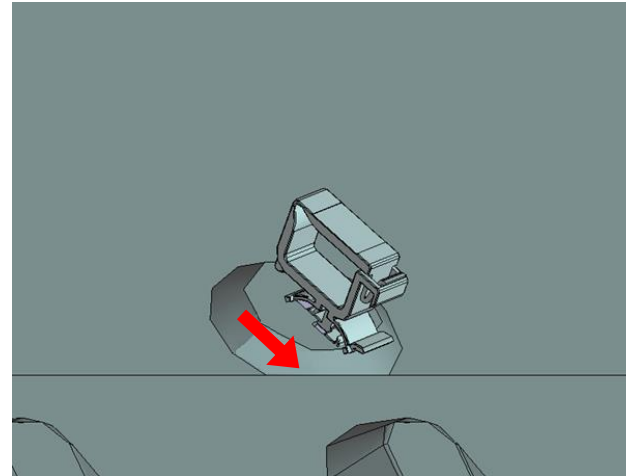

2

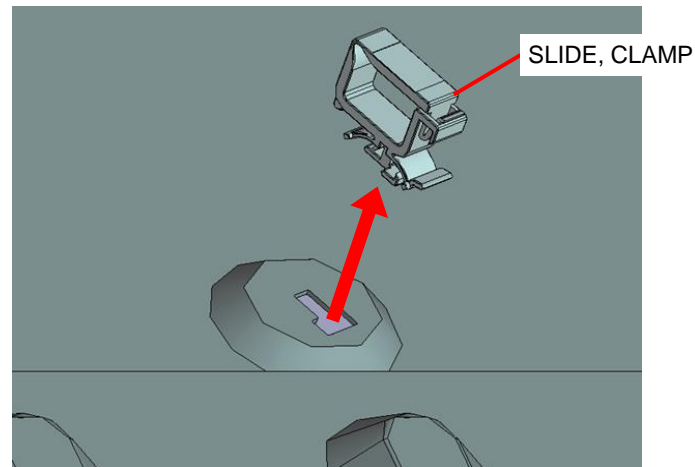

1-1. XBR-55X850C/855C/857C

1-1-30. LCD PANEL

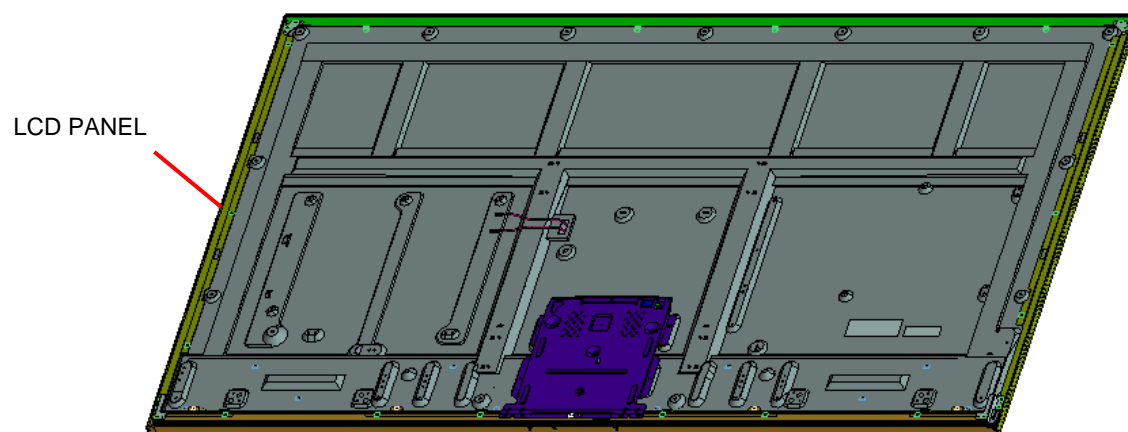

1-2. XBR-65X850C/855C/857C

1-2-1. STAND

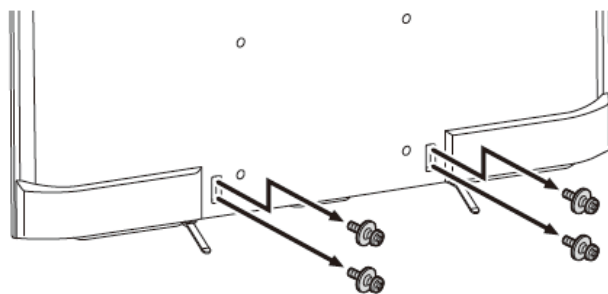

4 screws (SCREW, +PSW M6X12) P/N: 4-567-081-01

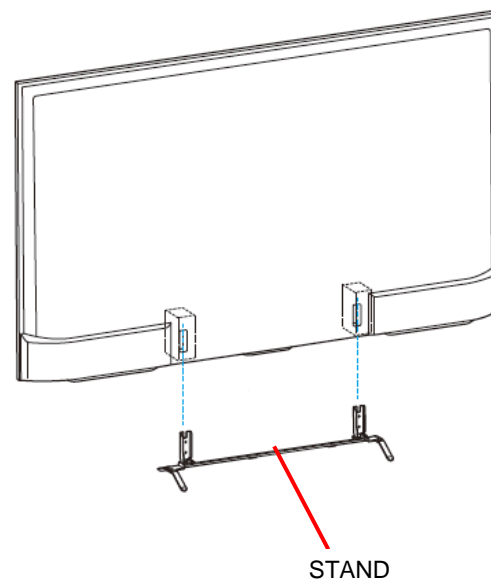

1-2. XBR-65X850C/855C/857C

1-2-2. LABEL, UNDER TERMINAL AND LABEL, REAR TERMINAL AND LABEL, SIDE TERMINAL (L) AND LABEL, CI

(CO1 ONLY)

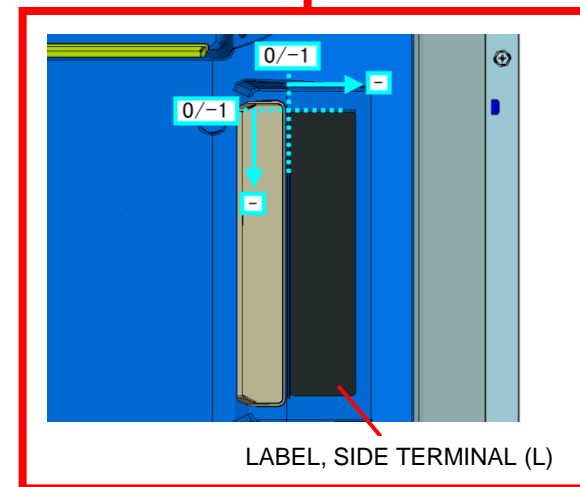
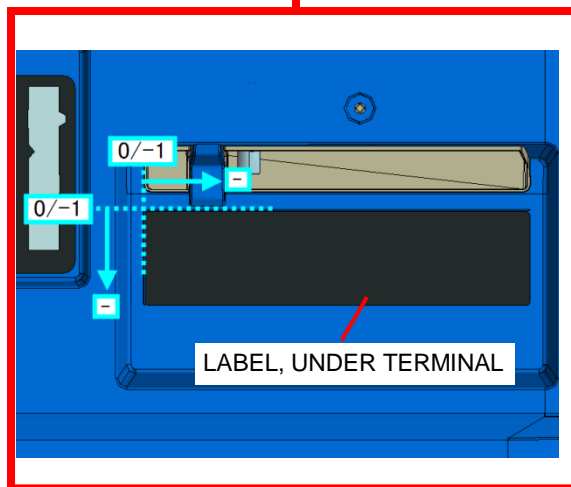
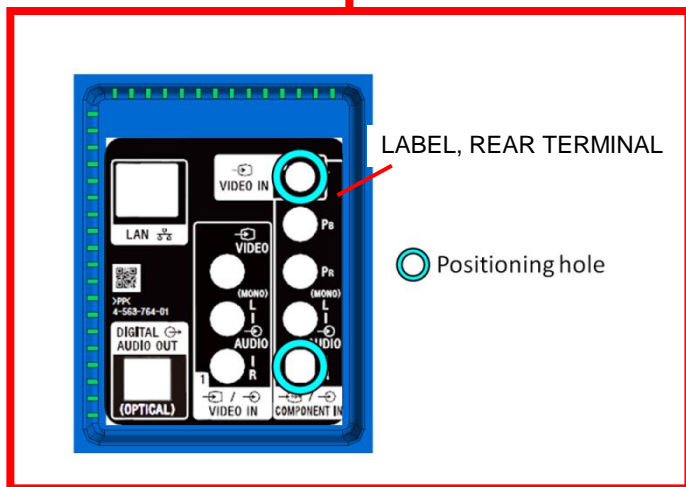
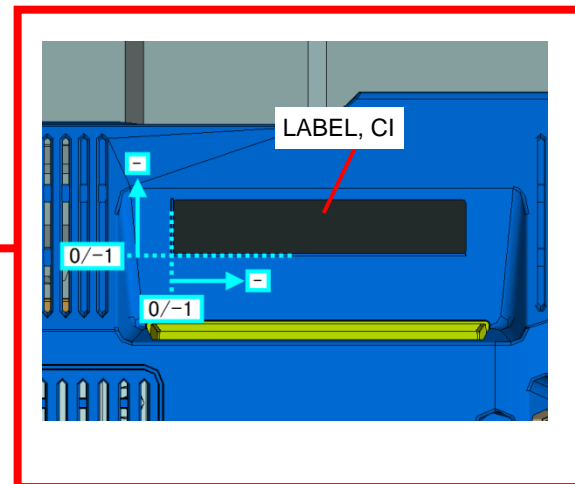
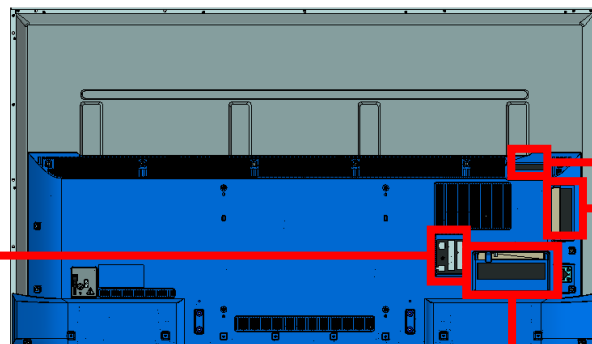

1-2. XBR-65X850C/855C/857C

1-2-3. AC COVER AND POWER SUPPLY CORD

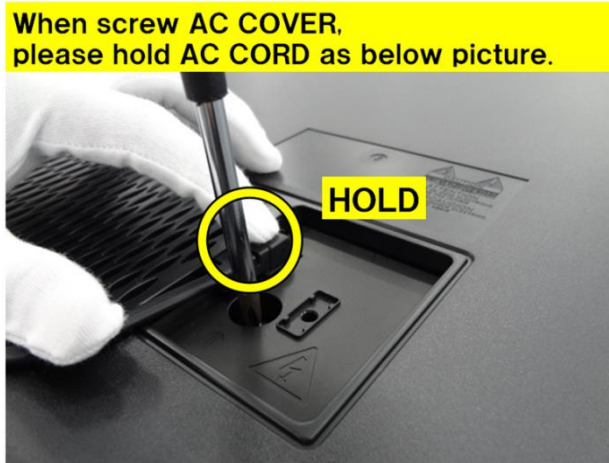
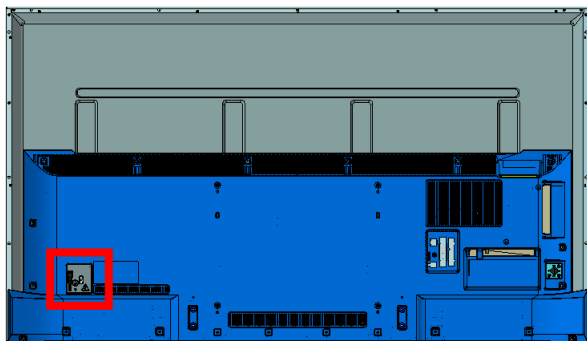

1

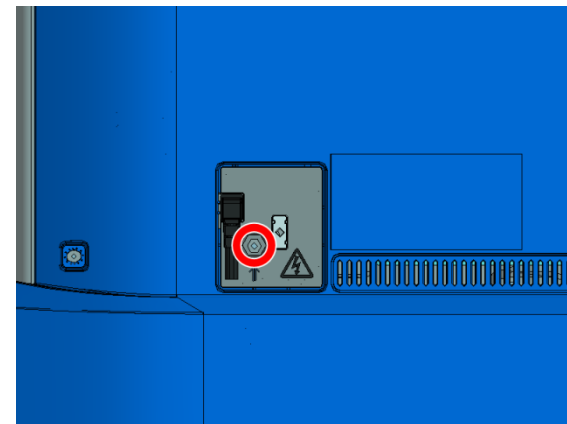

Screw (SCREW +PSW M4X10) P/N: 4-159-298-01

2

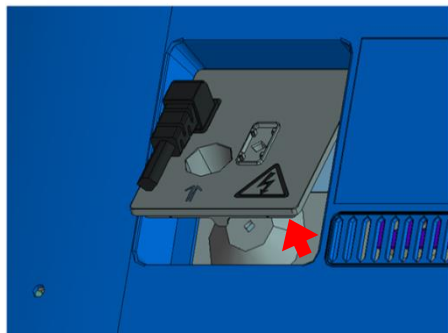

3

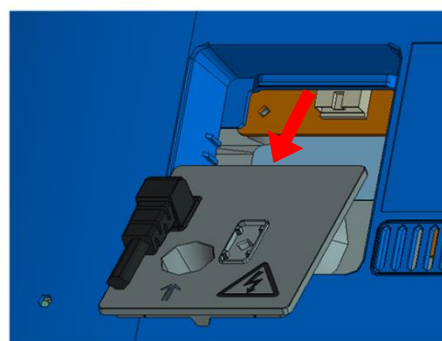

4

POWER SUPPLY CORD

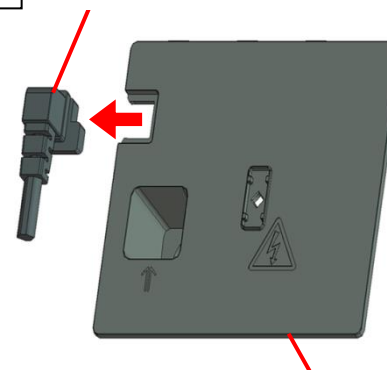

AC COVER

5

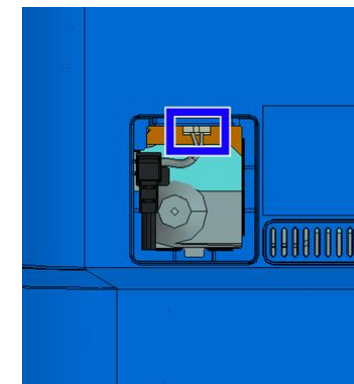

1-2. XBR-65X850C/855C/857C

1-2-4. UNDER COVER (2L_HWK) A

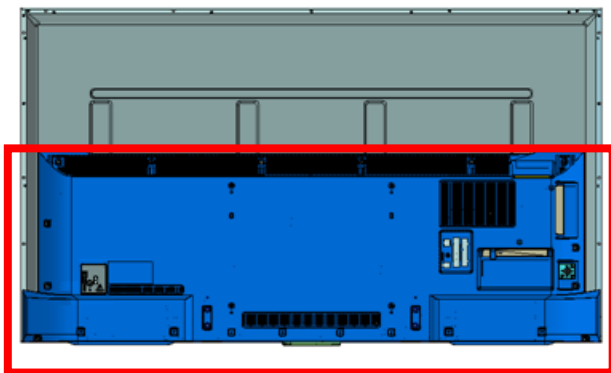

2

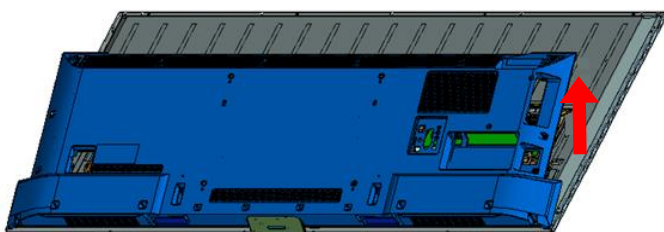

Ensure R/C is installed to slit of panel.

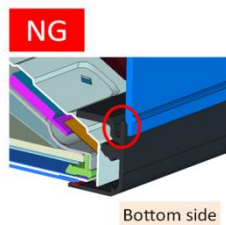
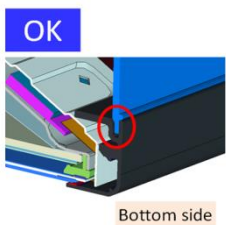

1

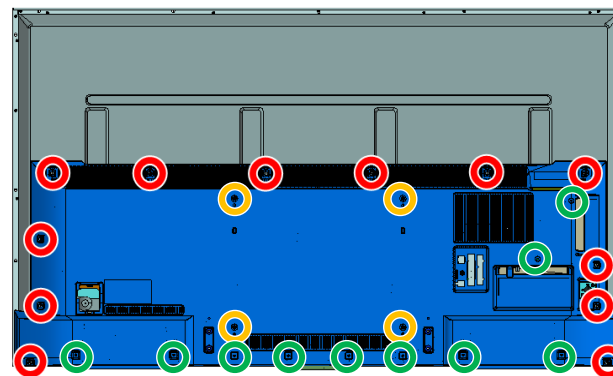

- 12 screws (SCREW , +PWH M3X6) P/N: 4-452-935-11
- 4 screws (SCREW, ORNAMENTAL M6X12) P/N: 4-268-126-02
- 10 screws (SCREW, +BVTP 4X12 TYPE2 IT-3) P/N: 2-580-639-01

3

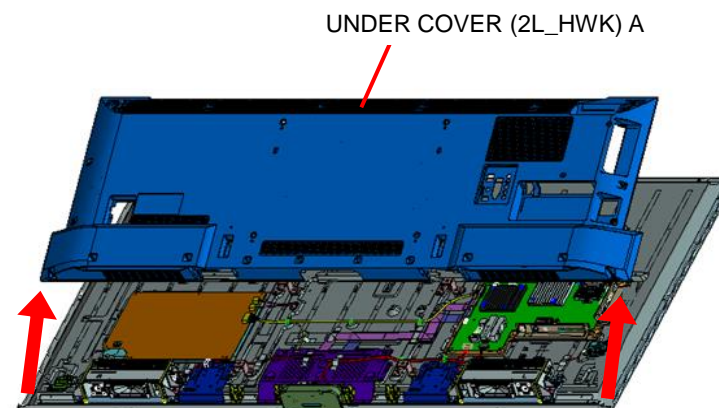

1-2. XBR-65X850C/855C/857C

1-2-5. TAPE

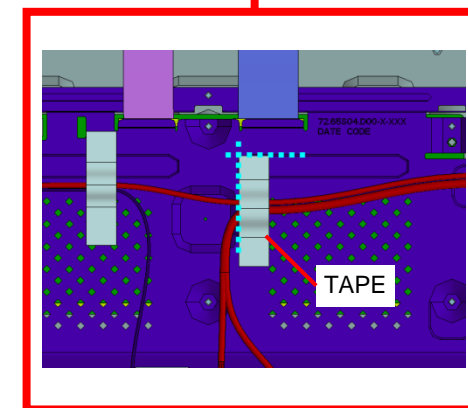
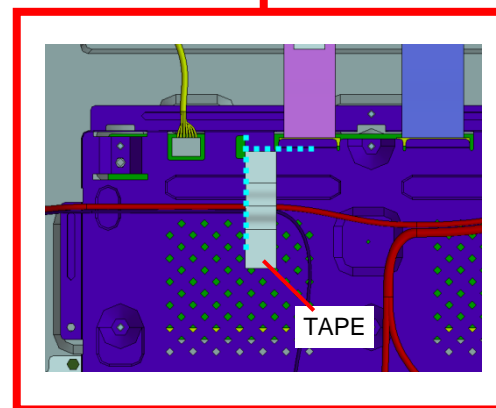
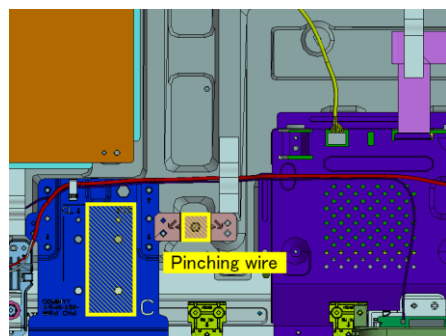
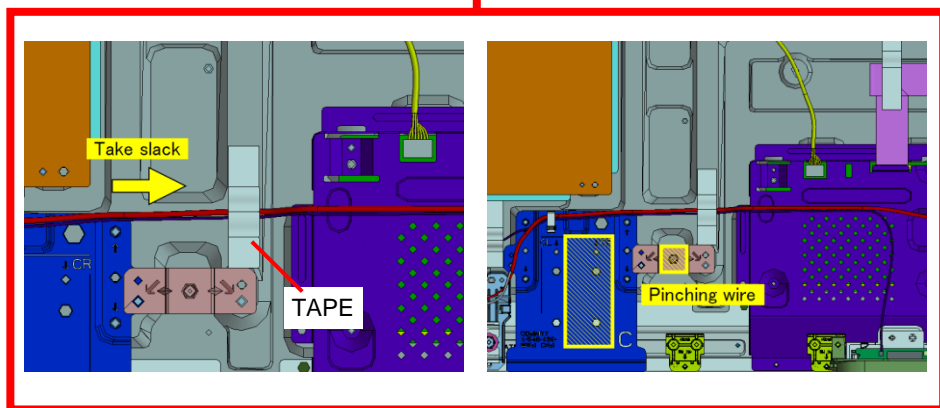
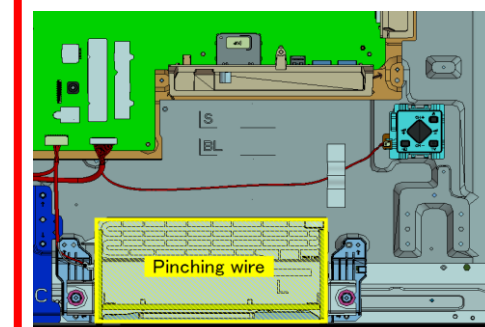
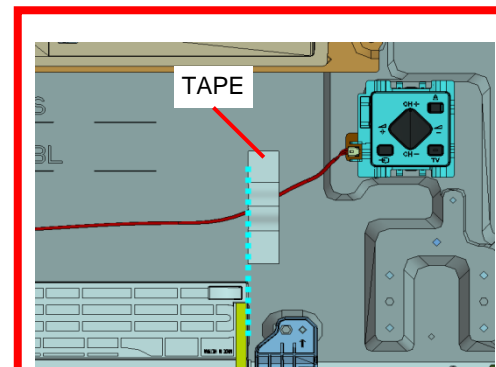
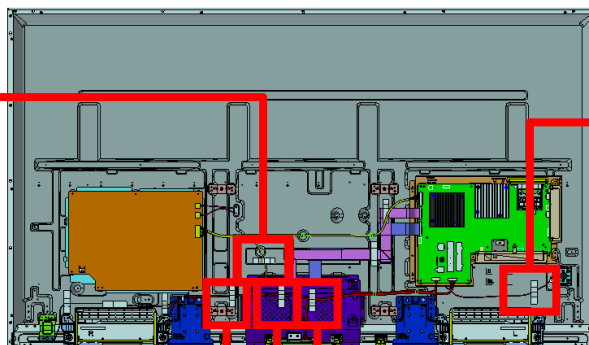
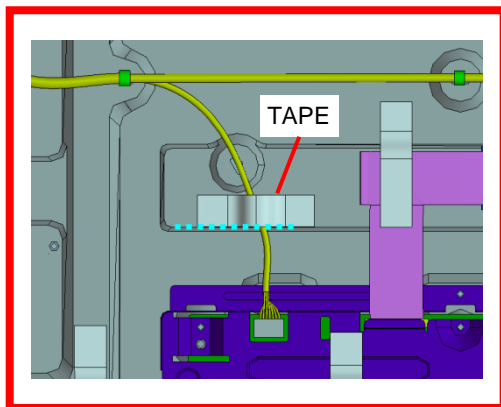

1-2. XBR-65X850C/855C/857C

1-2-6. TAPE

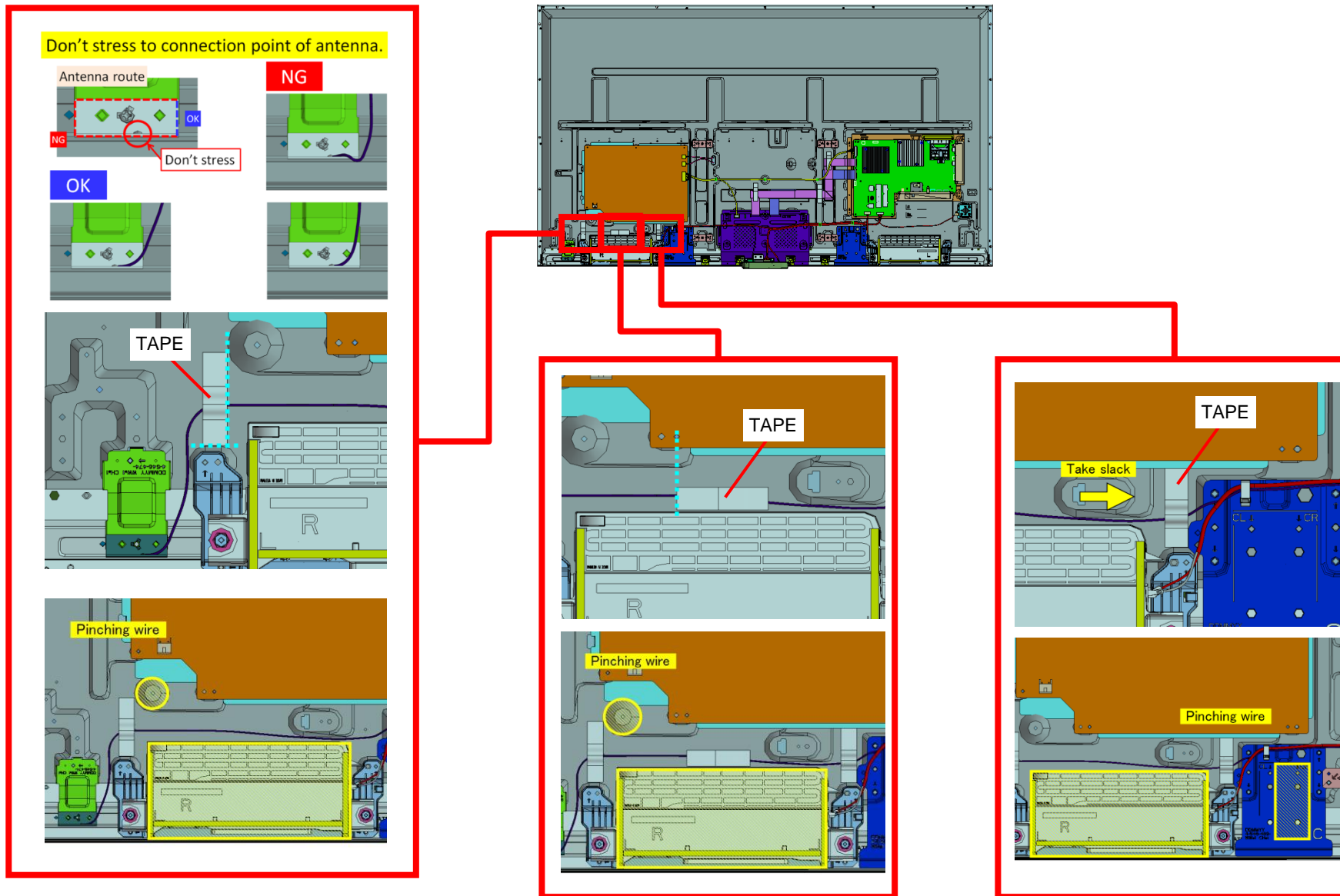

1-2. XBR-65X850C/855C/857C

1-2-7. WIRE DRESSING

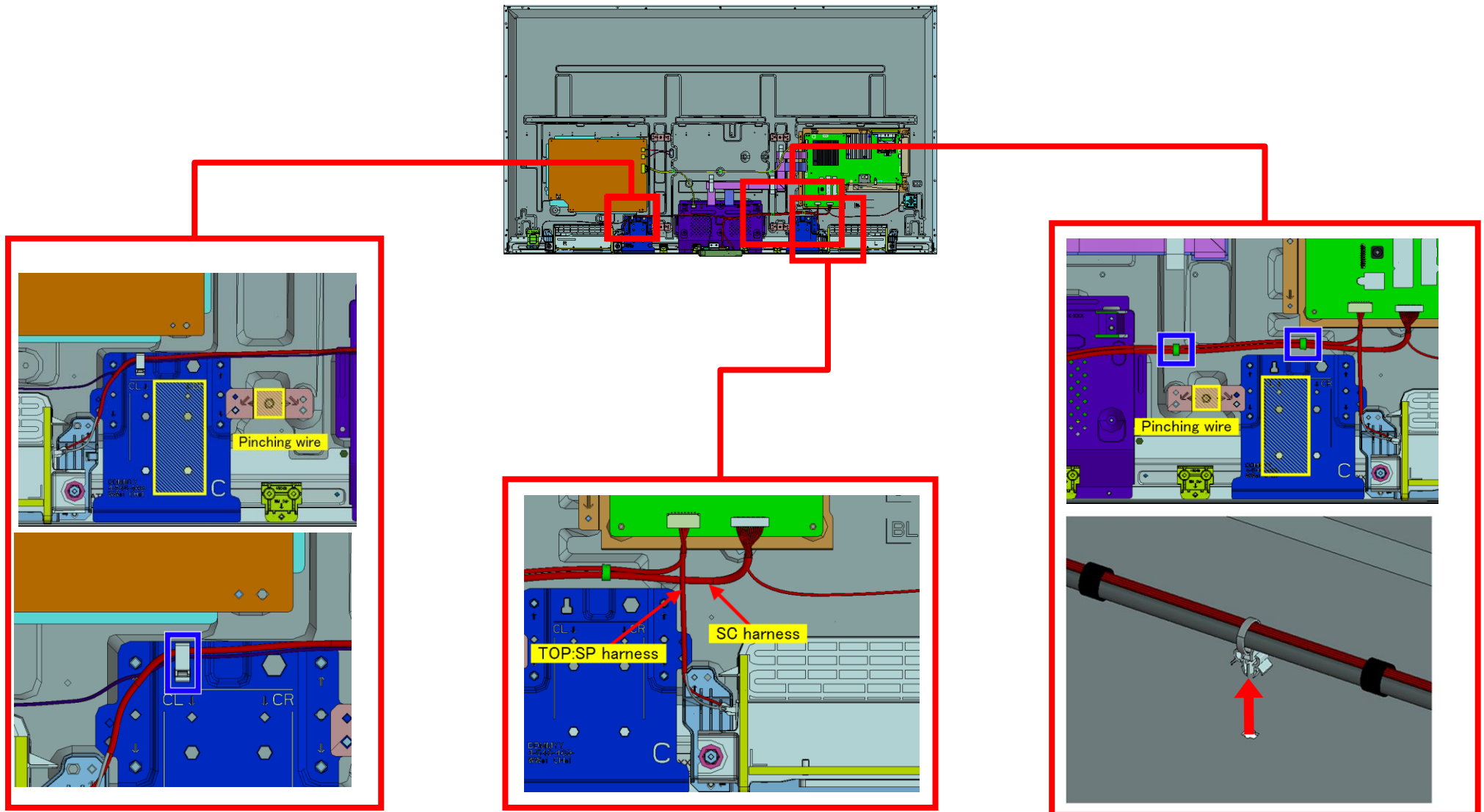

1-2. XBR-65X850C/855C/857C

1-2-8. SPEAKER BOX ASSY (L)

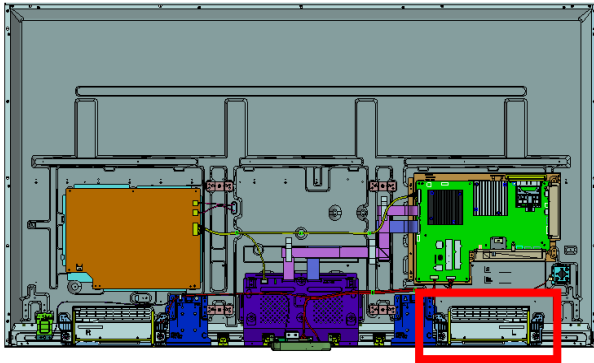

1

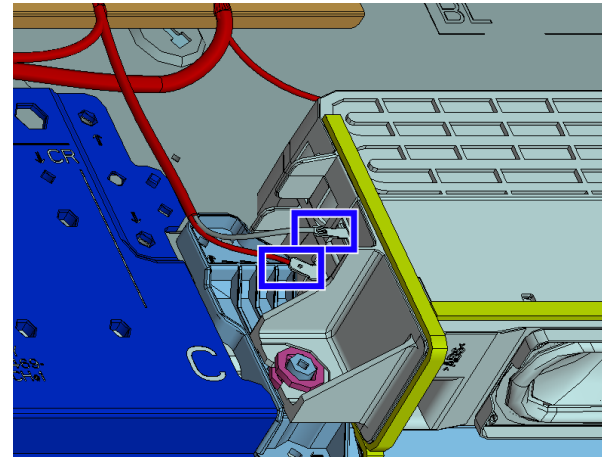

2

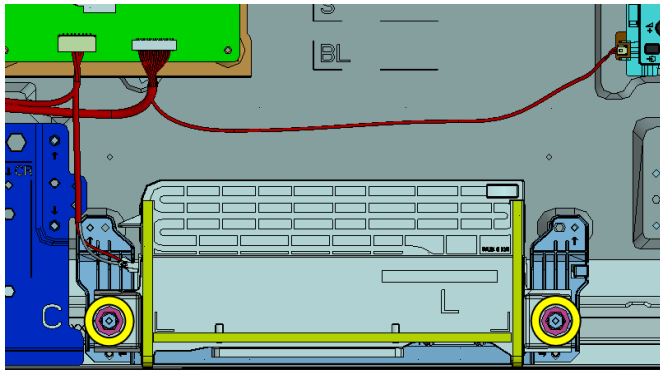

3

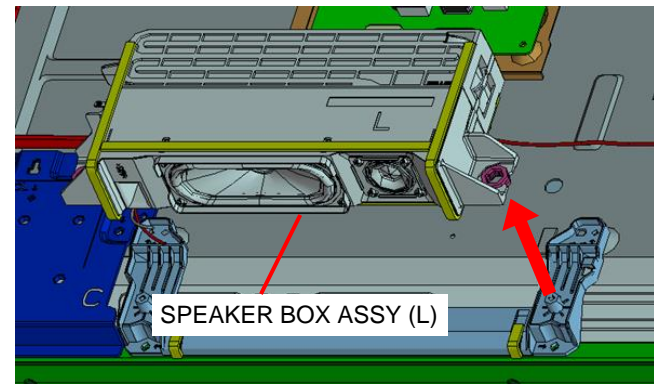

1-2. XBR-65X850C/855C/857C

1-2-9. BRACKET, SP (2L HWK) A

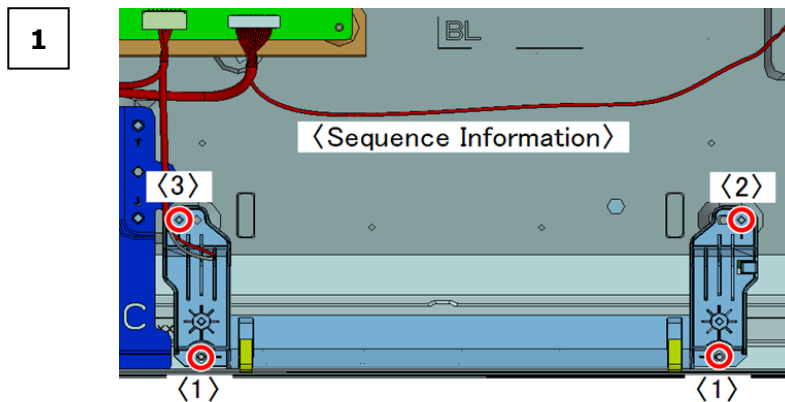
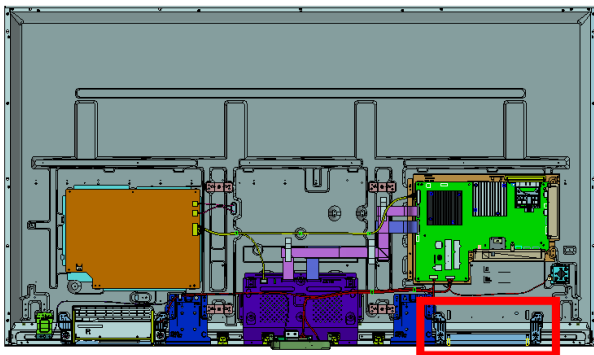

4 screws (SCREW , +PSW M3X8) P/N: 2-580-593-01

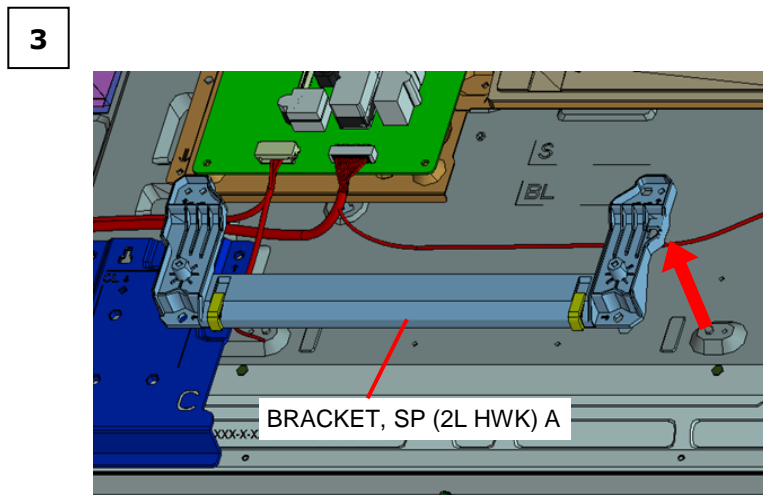
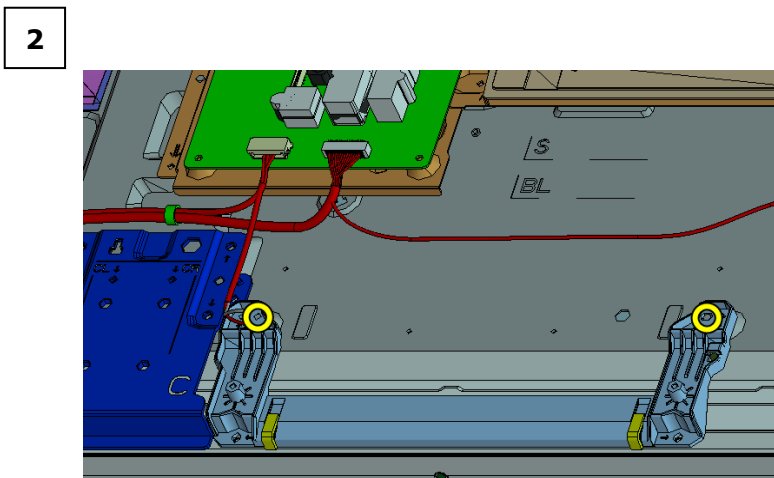

1-2. XBR-65X850C/855C/857C

1-2-10. SPEAKER BOX ASSY (R)

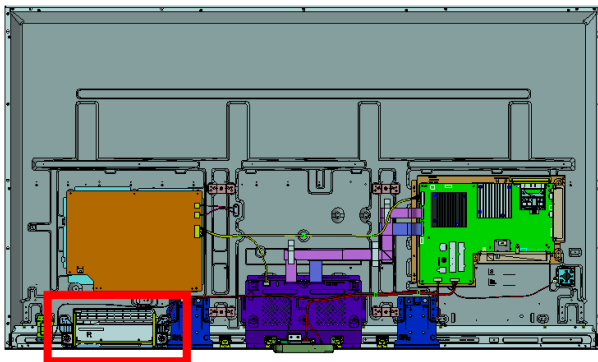

1

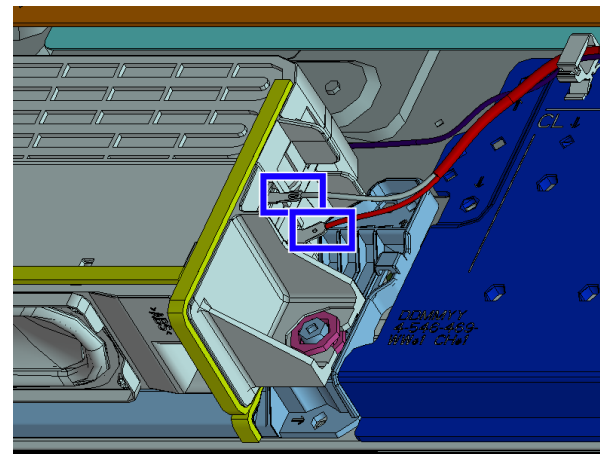

2

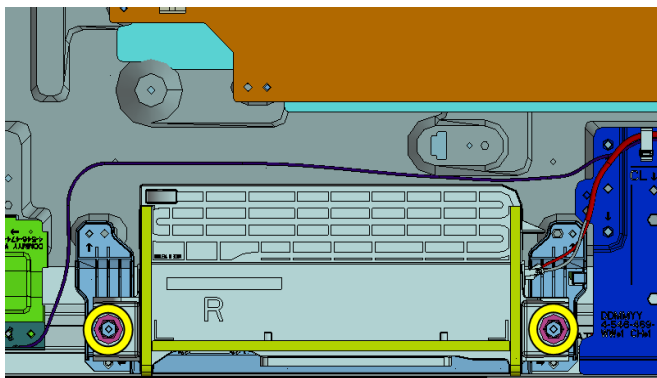

3

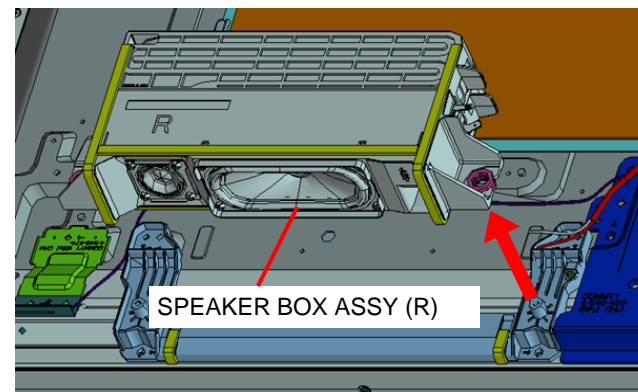

1-2. XBR-65X850C/855C/857C

1-2-11. BRACKET, SP (2L HWK) A

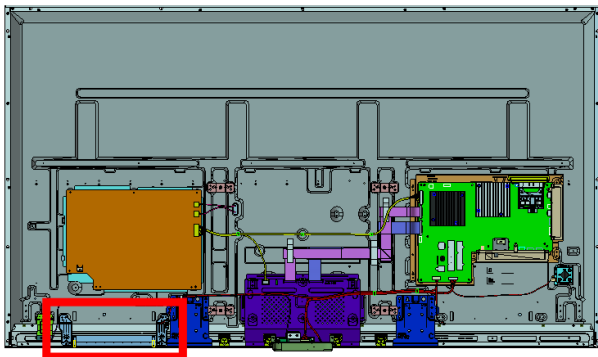

1

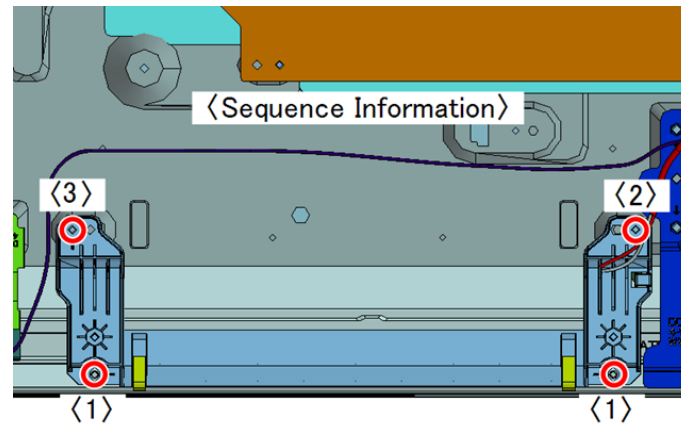

4 screws (SCREW , +PSW M3X8) P/N: 2-580-593-01

2

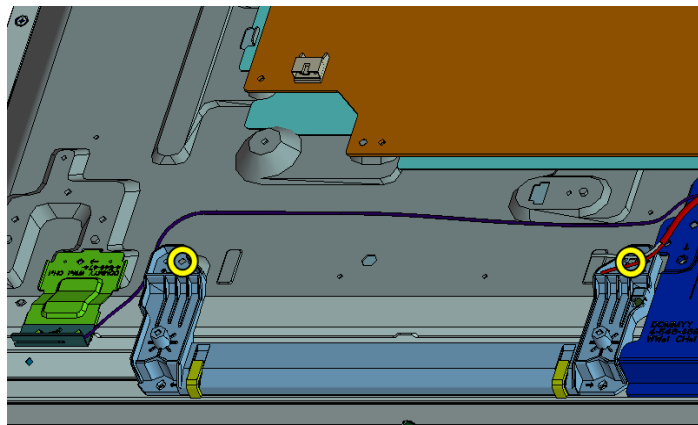

3

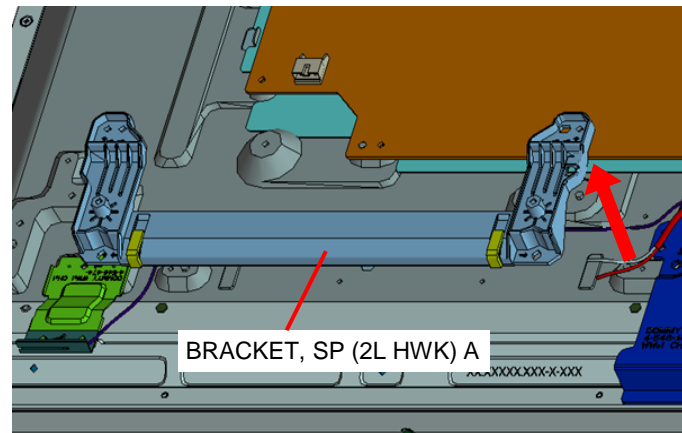

1-2. XBR-65X850C/855C/857C

1-2-12. BRACKET,BT (EGL) ASSY

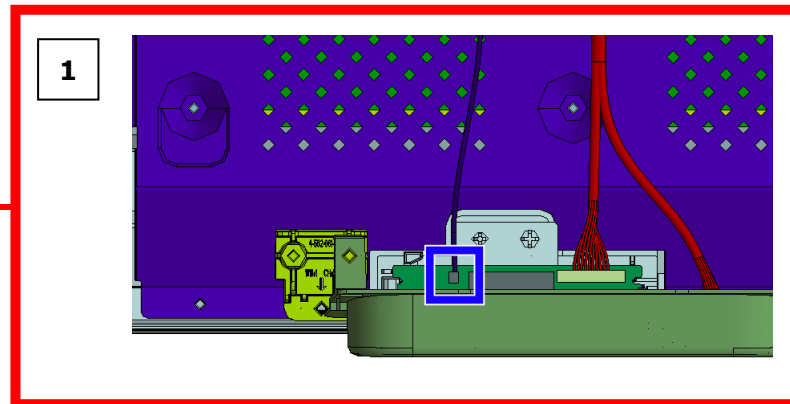
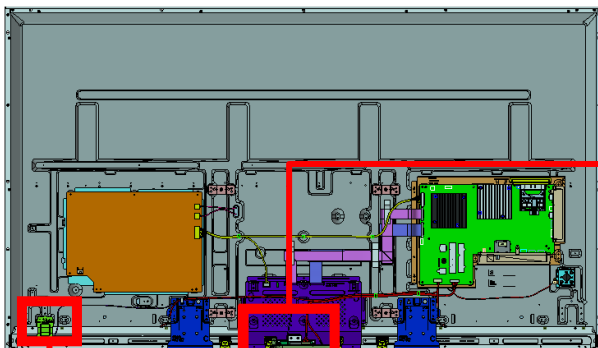

2

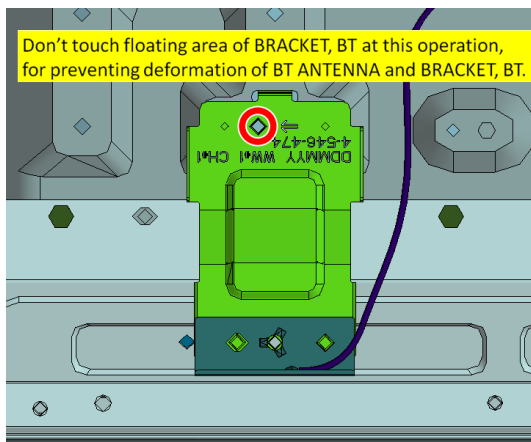

Screw (SCREW (+PSW)(M3X6))

P/N: 2-990-421-41

3

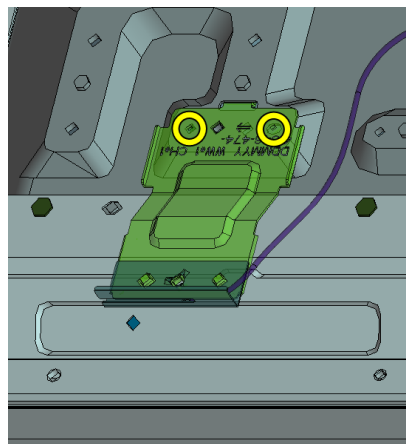

4

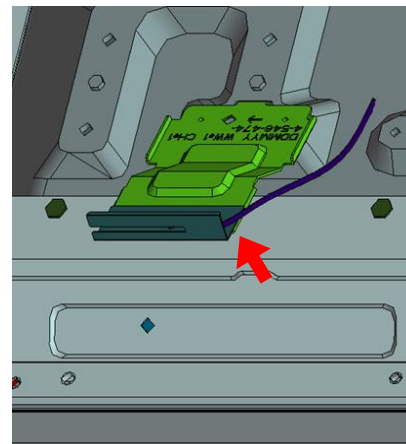

5

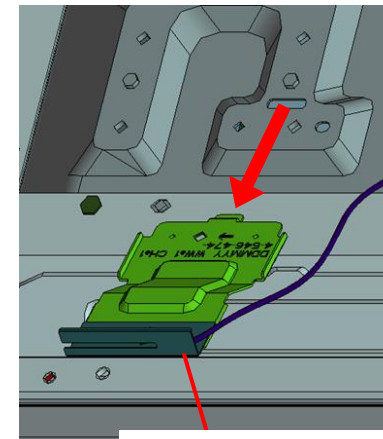

BRACKET,BT (EGL) ASSY

1-2. XBR-65X850C/855C/857C

1-2-13. BT ANTENNA/WIFI ANTENNA AND BRACKET, BT(EGL)

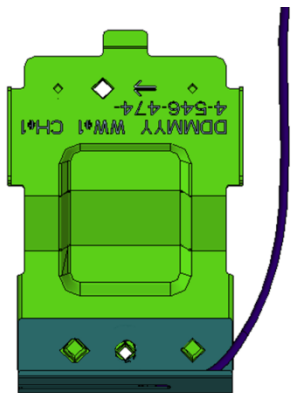

1

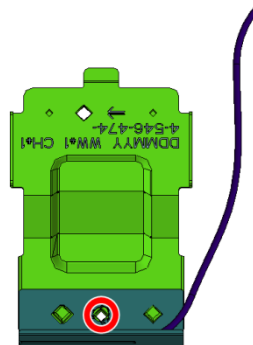

Screw (SCREW (+PSW)(M3X6))

P/N: 2-990-421-41

2

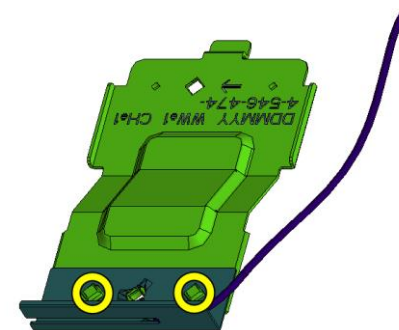

3

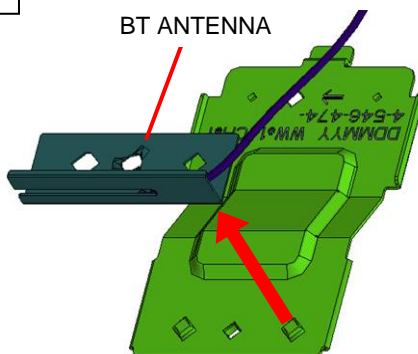

BT ANTENNA

4

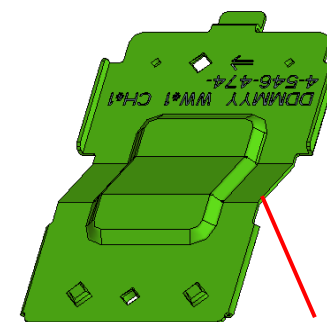

BRACKET,BT (EGL)

1-2. XBR-65X850C/855C/857C

1-2-14. SMART CORE

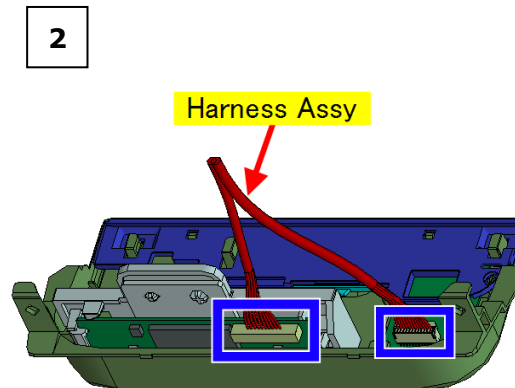
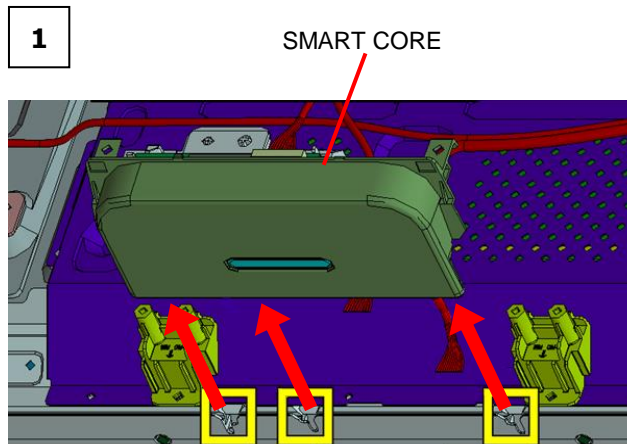
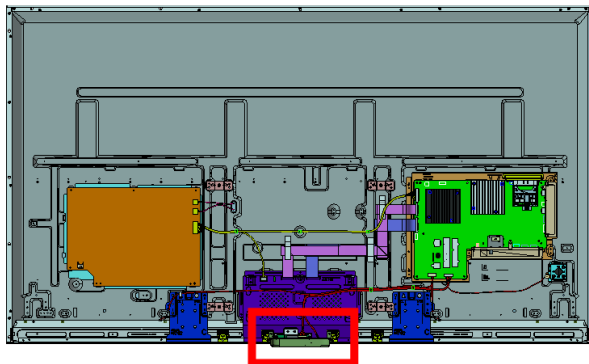

Notes on assembling the Smart core

Don't scratch O/P with Bezel while installing.

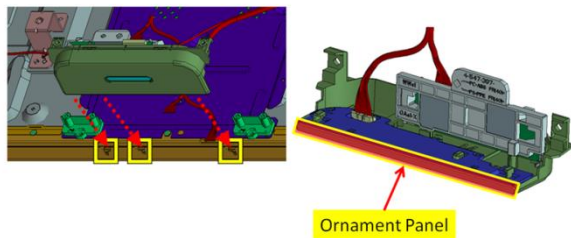

No gap between Smart Core and AL Bezel.

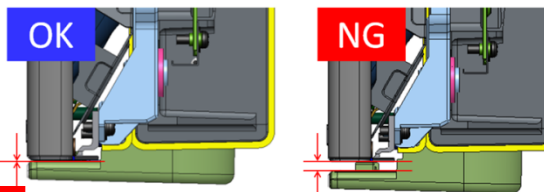

Front View of the TV

Don't touch these components while installing.

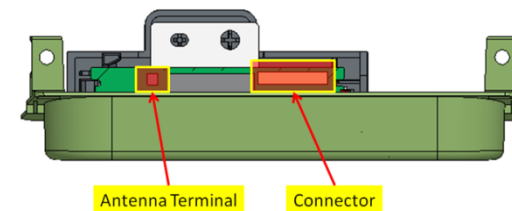

1-2. XBR-65X850C/855C/857C

1-2-15. SWITCH UNIT

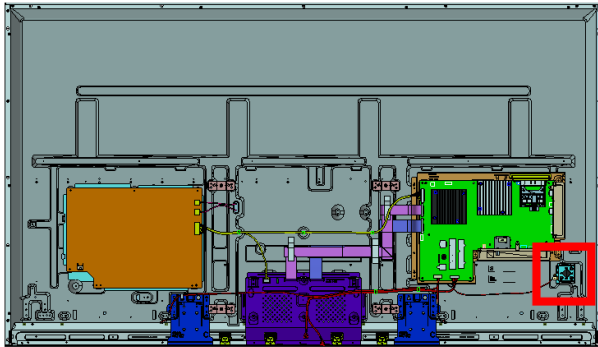

1

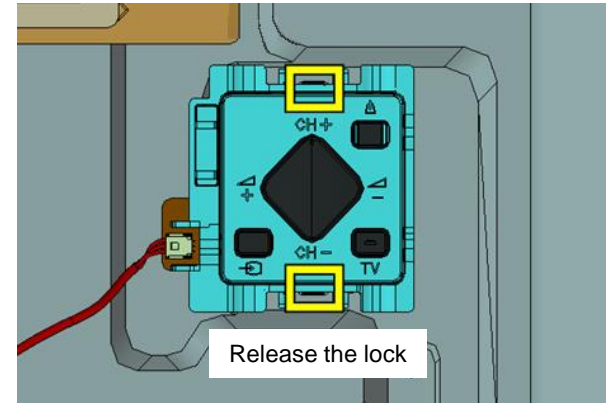

2

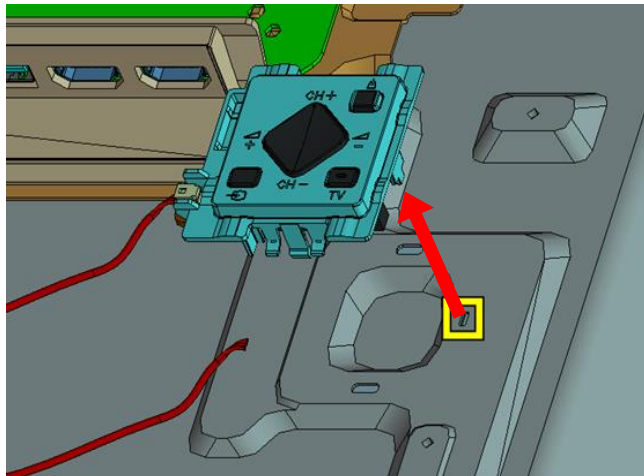

3

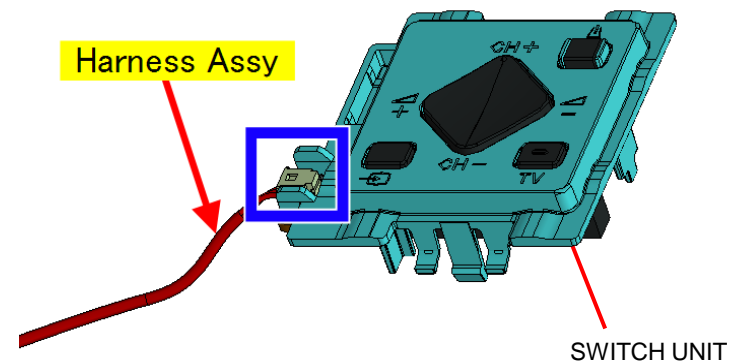

1-2. XBR-65X850C/855C/857C

1-2-16. HARNESS ASSY (MAIN) AND CONNECTOR ASSY 28P

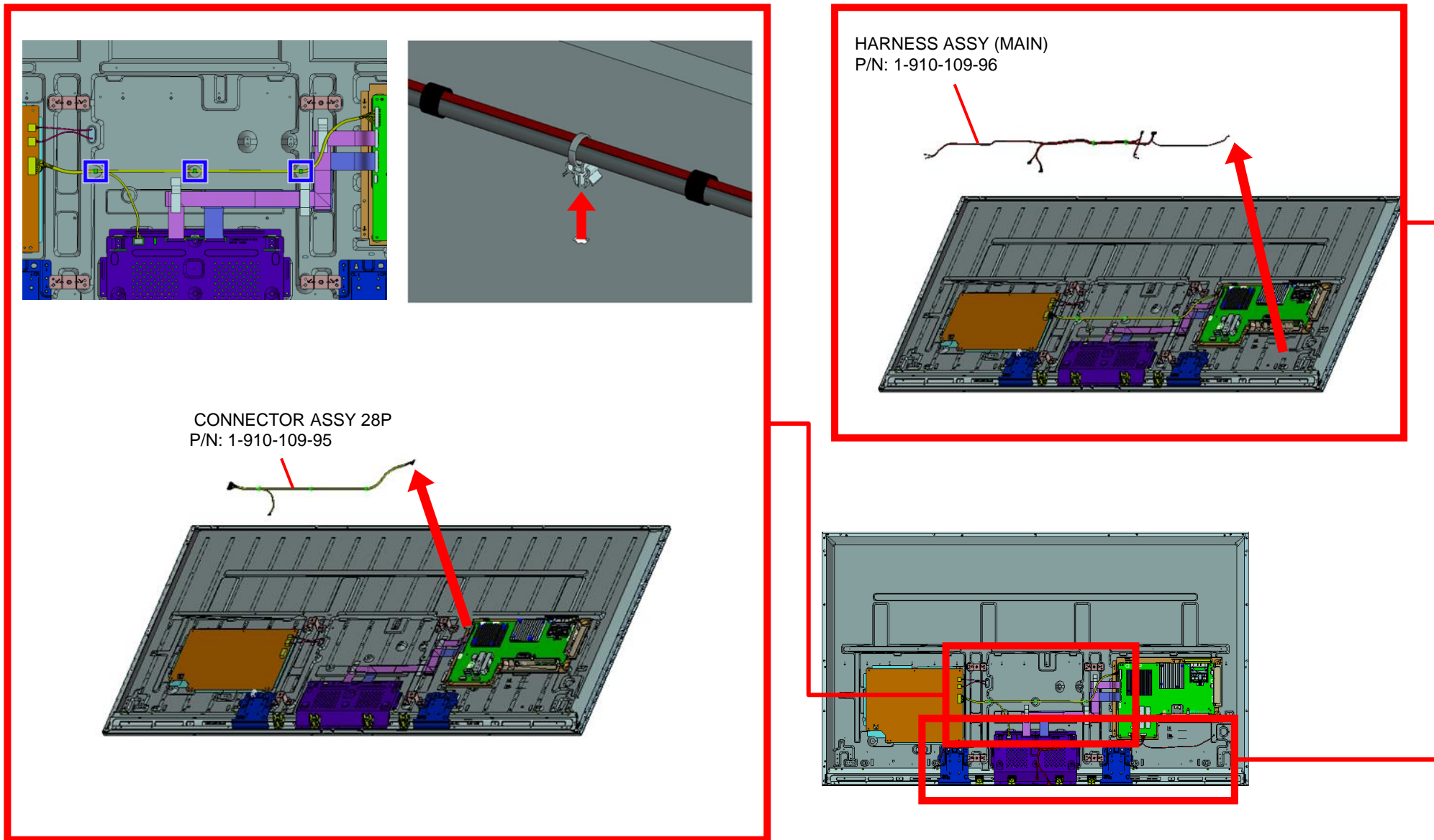

1-2. XBR-65X850C/855C/857C

1-2-17. BRACKET,VESA(HWK)

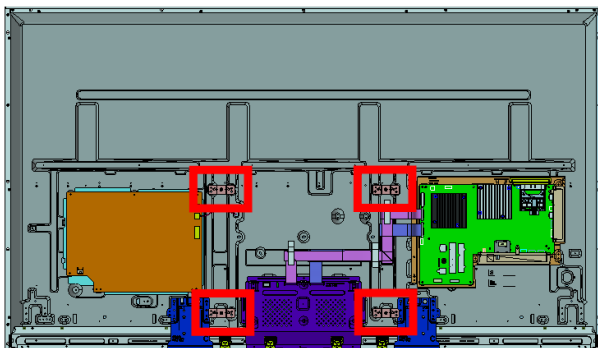

1

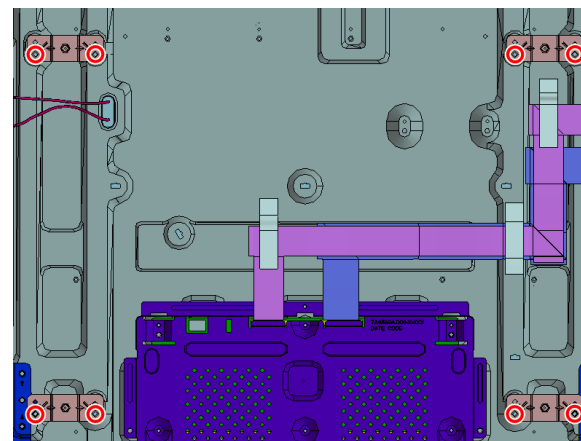

8 screws (SCREW, +PSW M4X8) P/N: 2-580-600-11

2

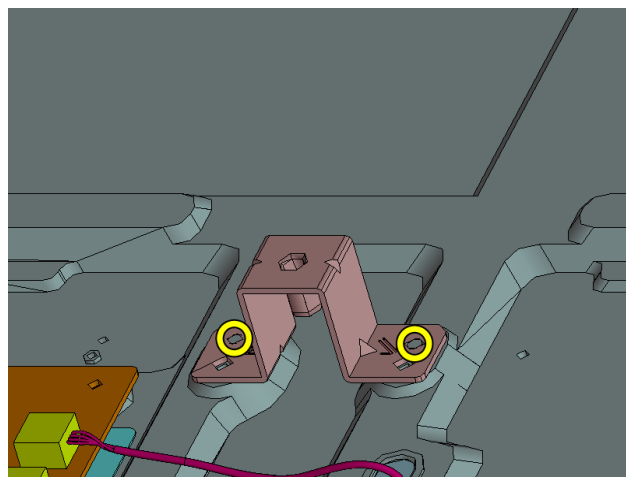

3

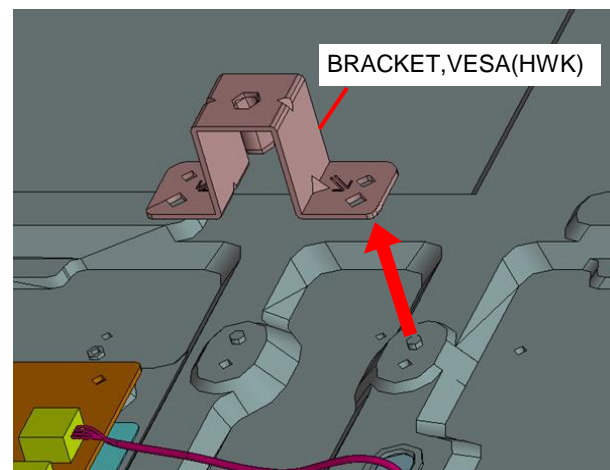

1-2. XBR-65X850C/855C/857C

1-2-18. BRACKET, SC(HWK)

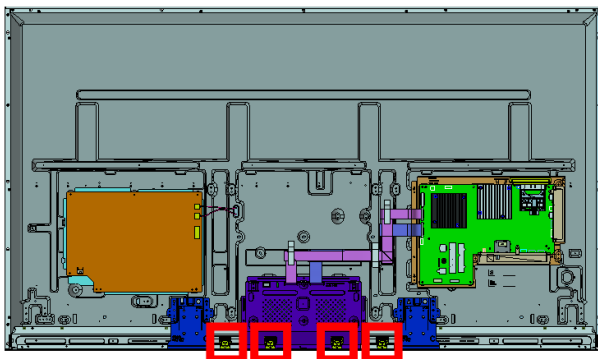

1

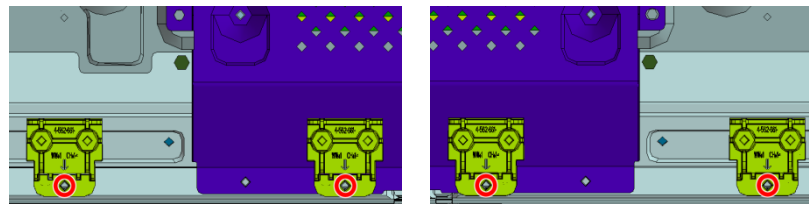

4 screws (SCREW, +PSW M3X8) P/N: 2-580-593-01

2

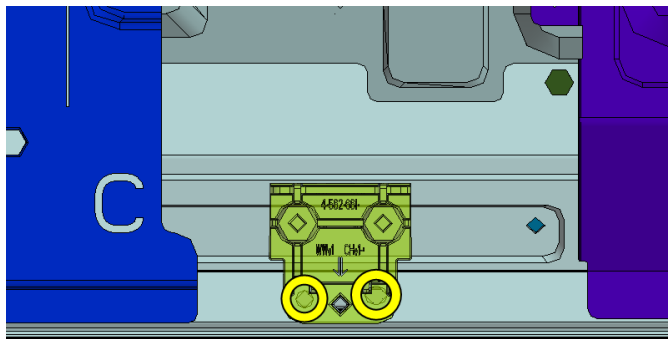

3

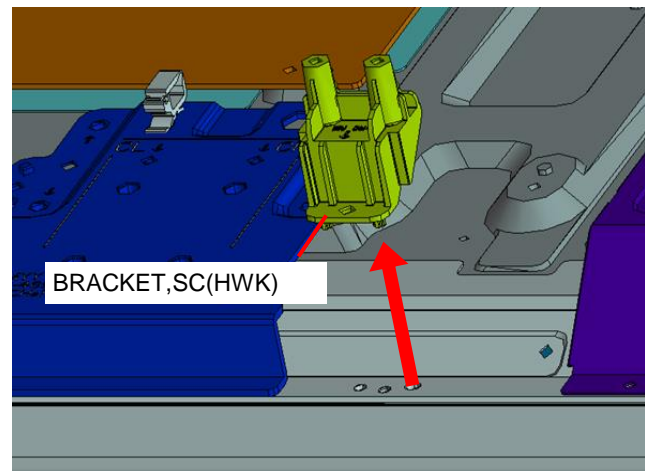

1-2. XBR-65X850C/855C/857C

1-2-19. SLIDE, CLAMP

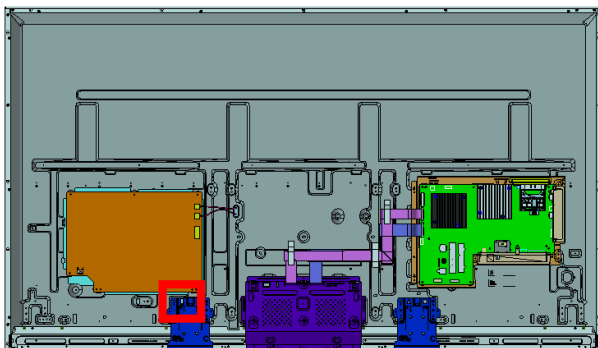

1

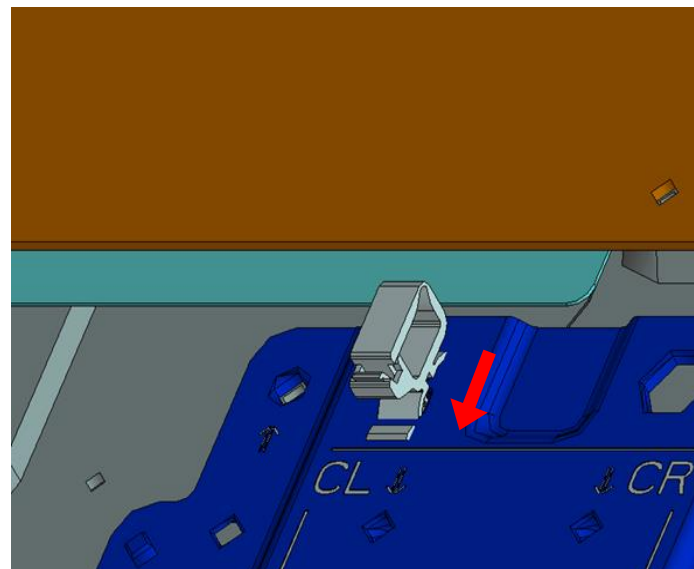

2

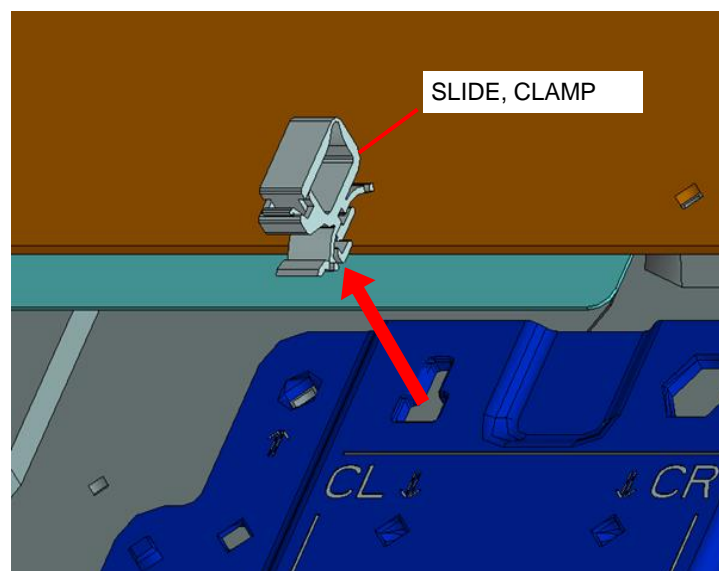

1-2. XBR-65X850C/855C/857C

1-2-20. BRACKET, STD C (2L_HWK) AND GASKET (HWK STD)

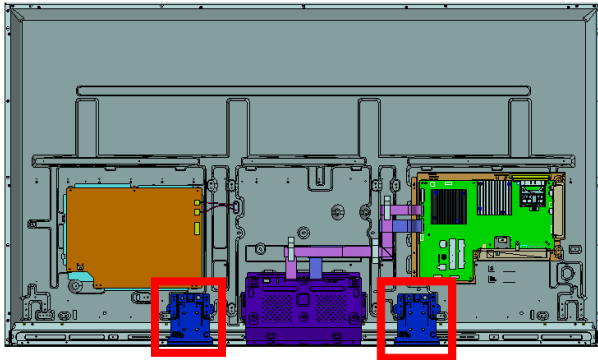

1

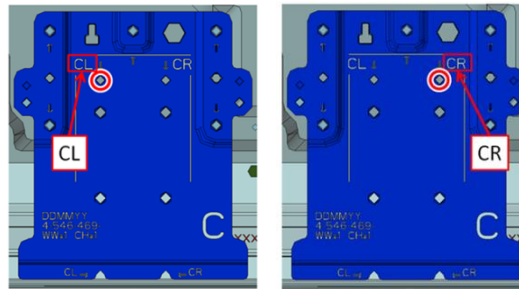

2 screws (PULLEY, STAND (HWI)) P/N: 4-534-964-01

2

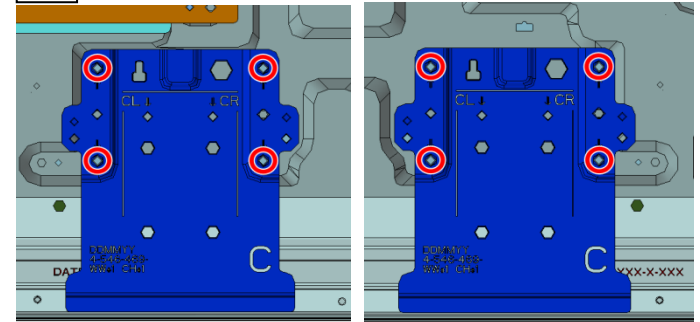

8 screws (SCREW, +PSW M4X8) P/N: 2-580-600-11

3

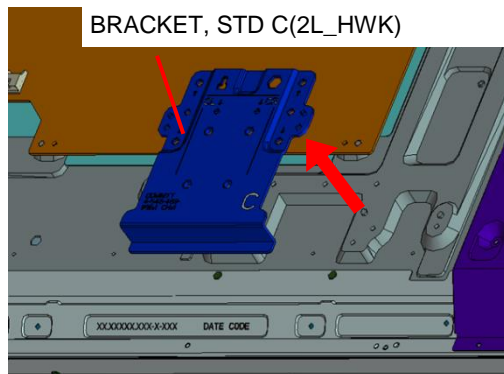

4

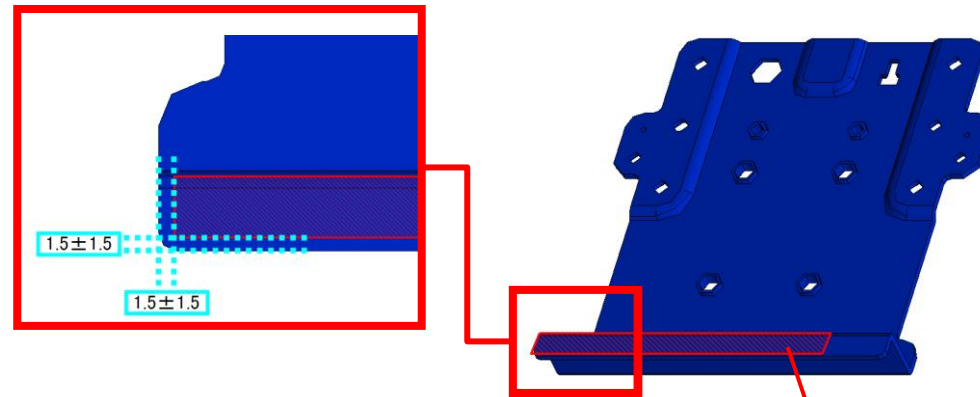

GASKET (HWK STD)

1-2. XBR-65X850C/855C/857C

1-2-21. GL1A(CH)-STATIC CONVERTER (TV)

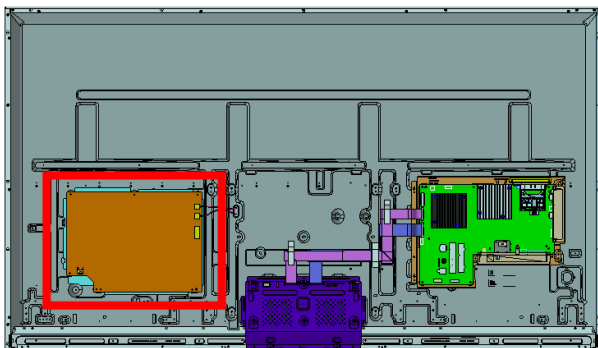

1

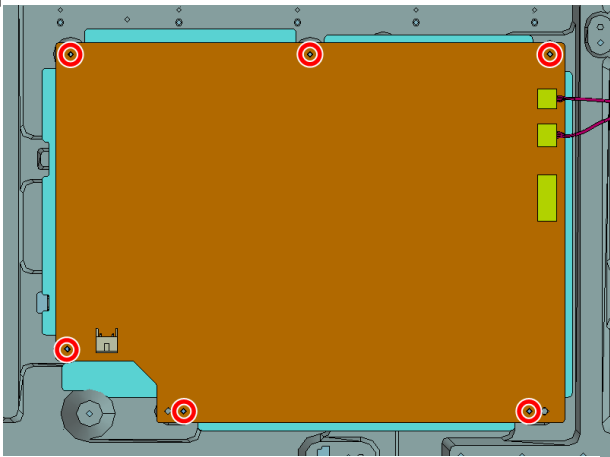

6 screws (SCREW, +PSW M3X6 W12) P/N: 4-256-393-11

2

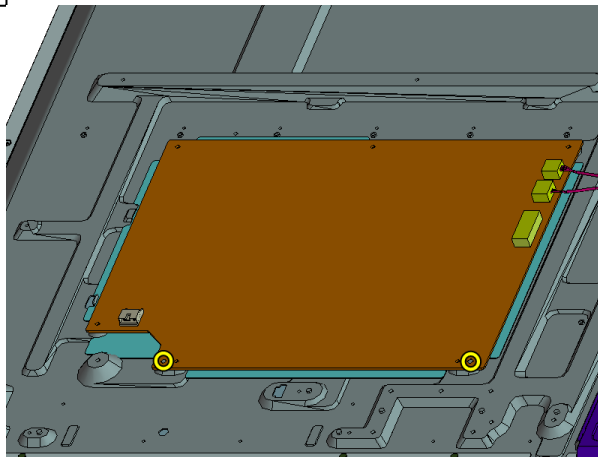

3

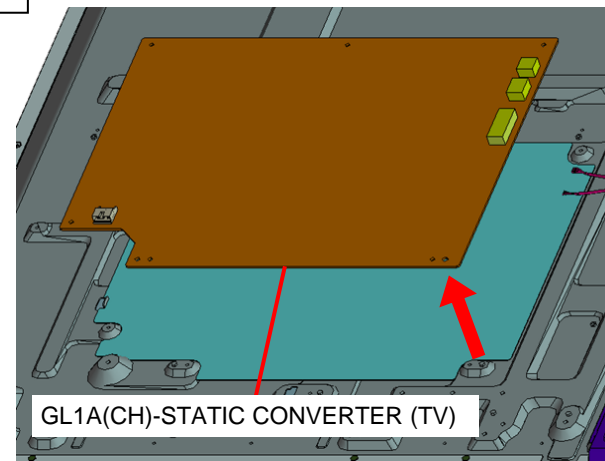

1-2. XBR-65X850C/855C/857C

1-2-22. SHEET, INSULATION(HWK 2L)

(An insulation sheet is under the GL1A power supply board)

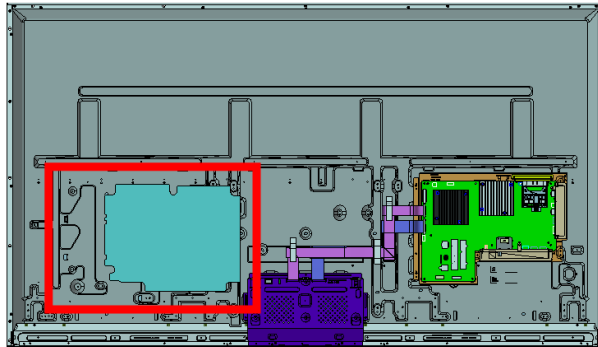

1



2

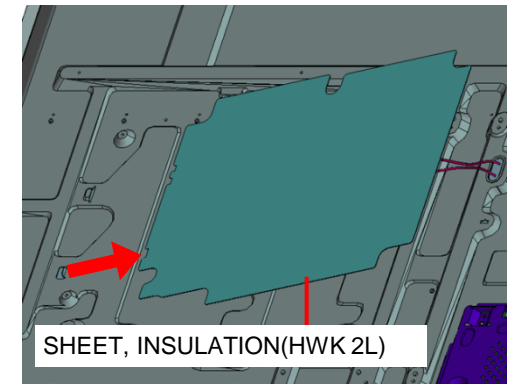

Notes on assembling the Insulation sheet (HWK 2L)

Adhesive tape area

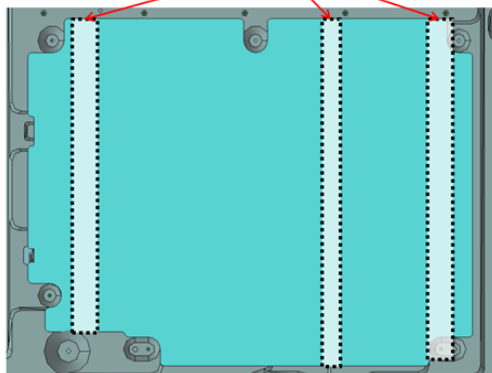

Caution

When handling,
 • Be sure not to touch adhesive tape area.
 After installing,
 • Be sure to push all of adhesive tape area to avoid peel off of "Sheet, Insulation".

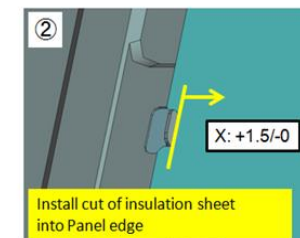
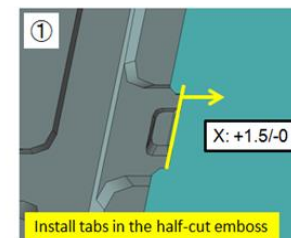
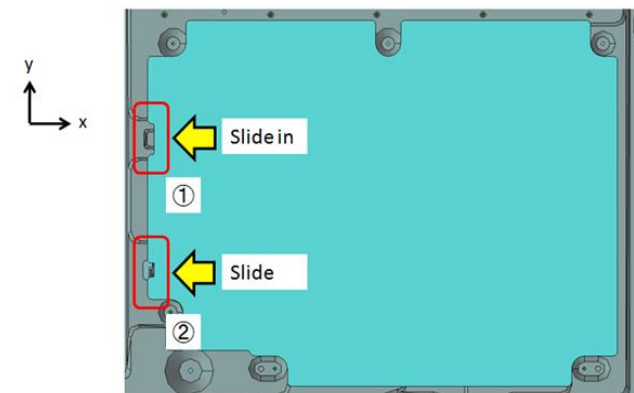

1-2. XBR-65X850C/855C/857C

1-2-23. TAPE

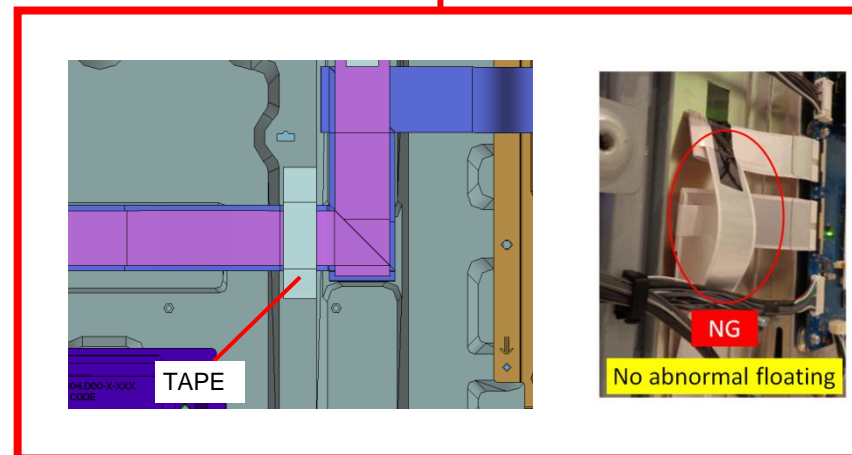
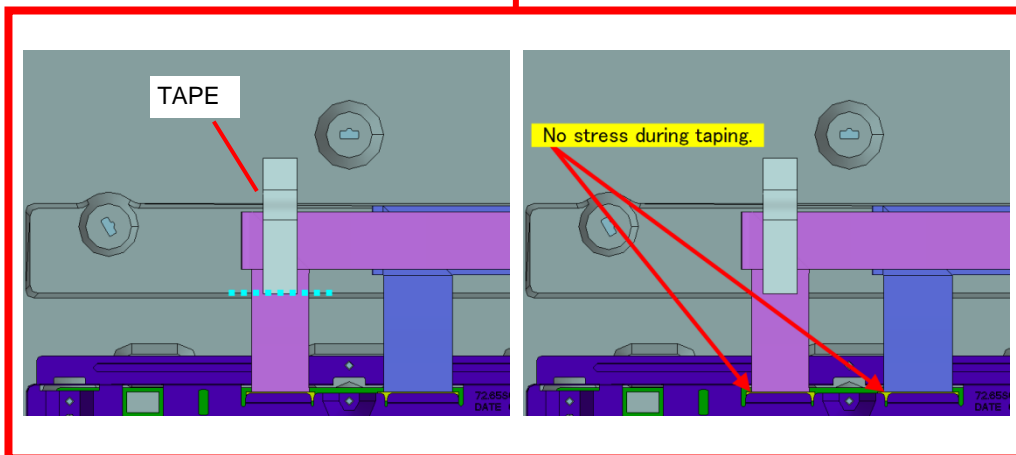
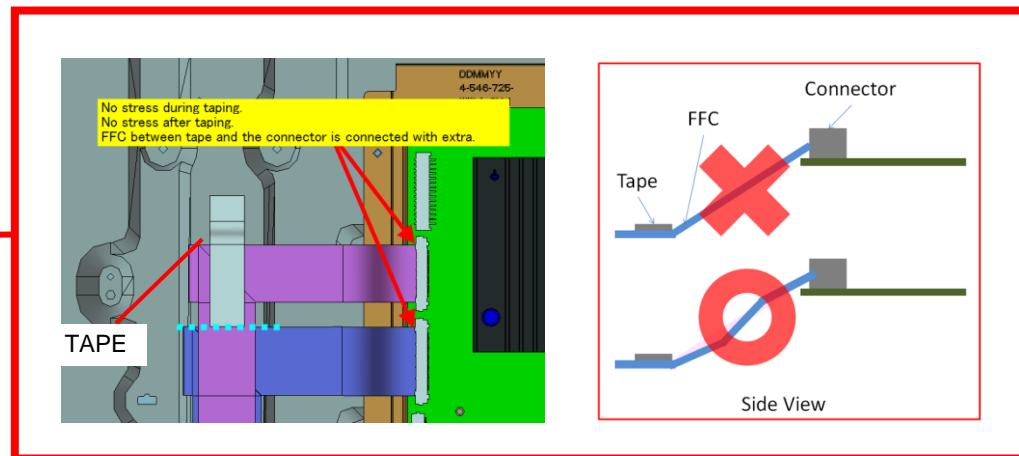
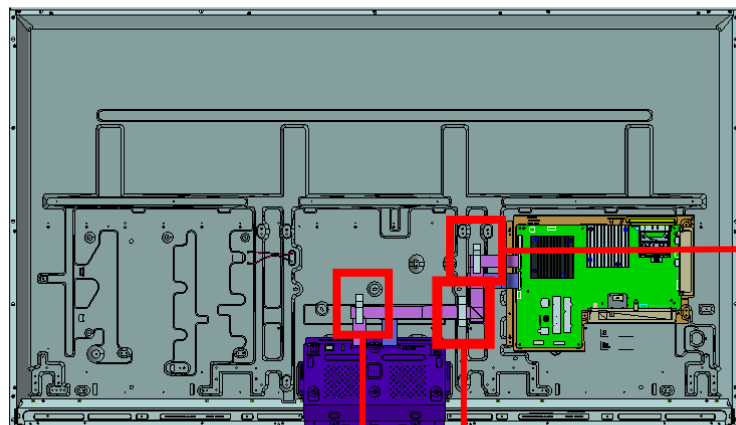

1-2. XBR-65X850C/855C/857C

1-2-24. CABLE, FLEXIBLE FLAT 41P AND CABLE, FLEXIBLE FLAT 51P

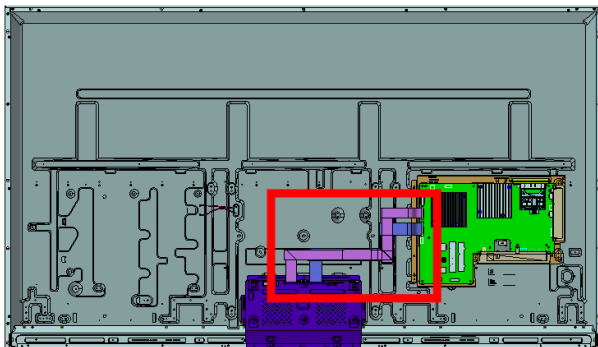

1

CABLE, FLEXIBLE FLAT 41P
 P/N: 1-848-870-11 (Except BR6)
 FLEXIBLE FLAT CABLE 41P
 P/N: 1-848-872-11 (BR6)

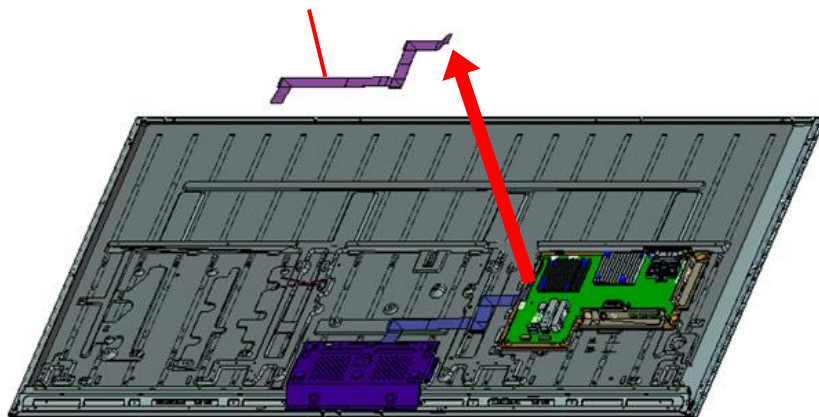

2

CABLE, FLEXIBLE FLAT 51P
 P/N: 1-848-871-11 (Except BR6)
 FLEXIBLE FLAT CABLE 51P
 P/N: 1-848-873-11 (BR6)

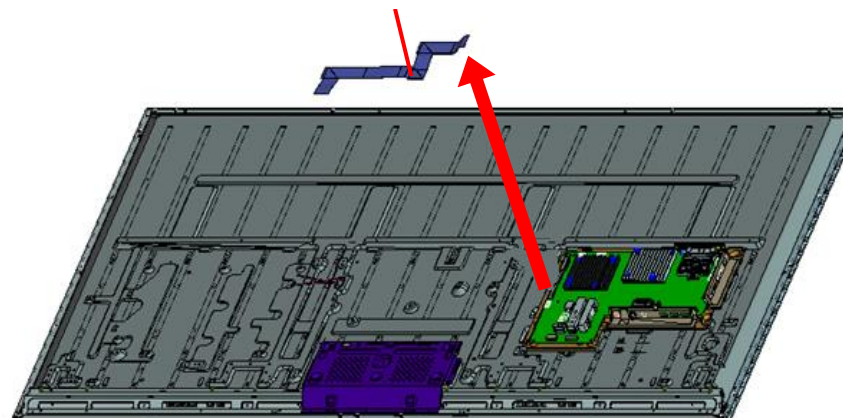

1-2. XBR-65X850C/855C/857C

1-2-25. BRACKET, UNDER FL (MOLD)

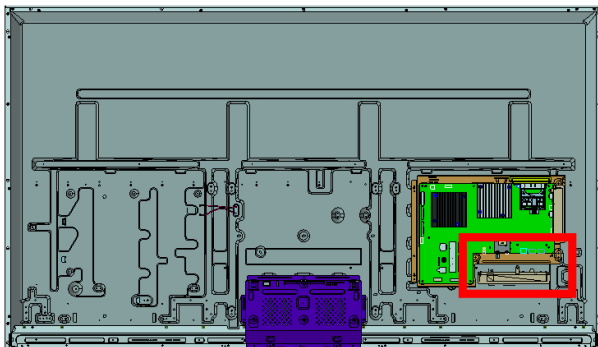

1

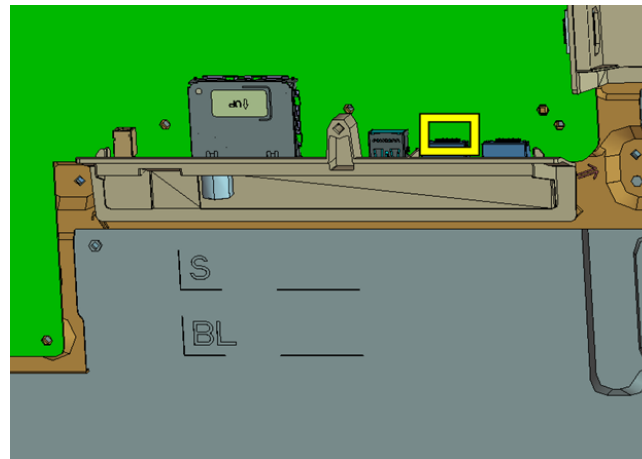

2

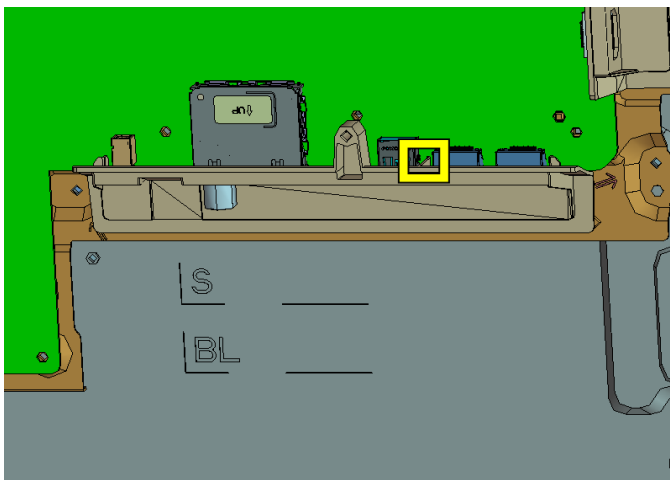

3

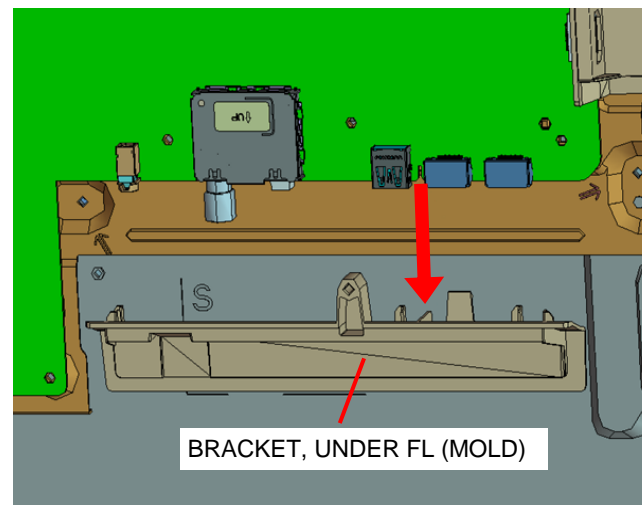

1-2. XBR-65X850C/855C/857C

1-2-26. BRACKET, SIDE FL (MOLD)

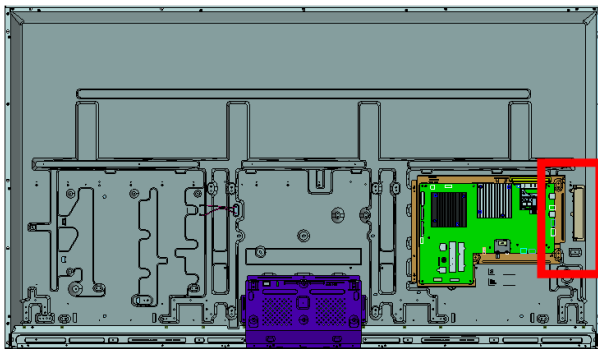

1



2

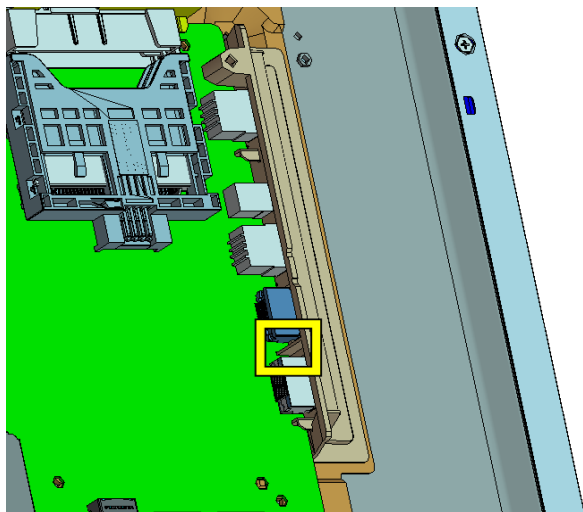

3

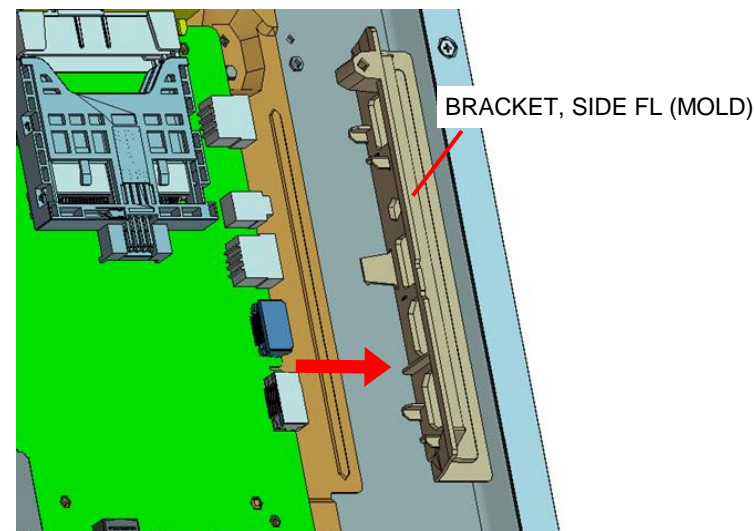

1-2. XBR-65X850C/855C/857C

1-2-27. BRACKET, TOP FL (MOLD)

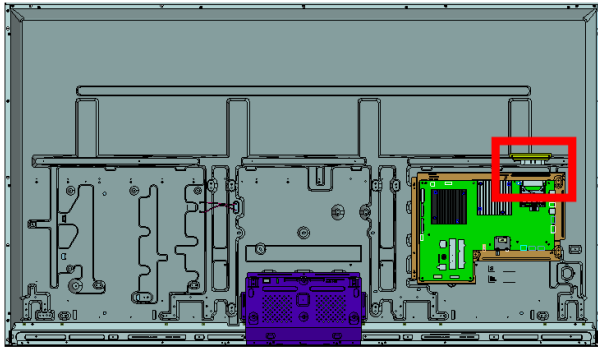

1

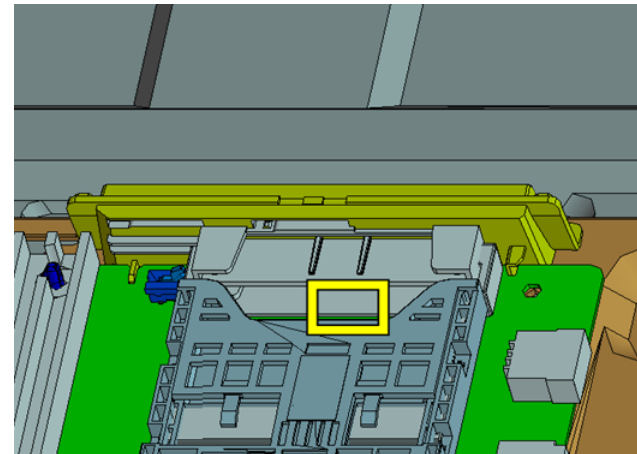

2

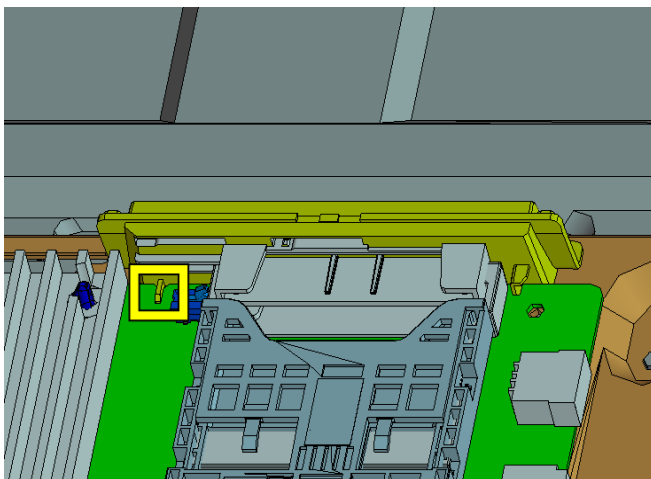

3

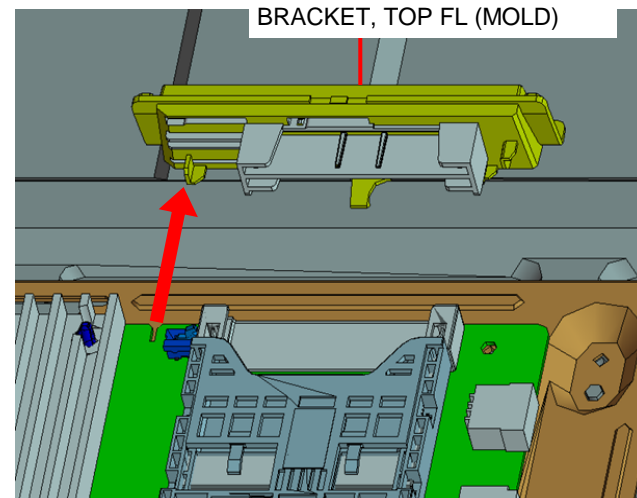

1-2. XBR-65X850C/855C/857C

1-2-28. PLATE, MAIN(HWK) ASSY

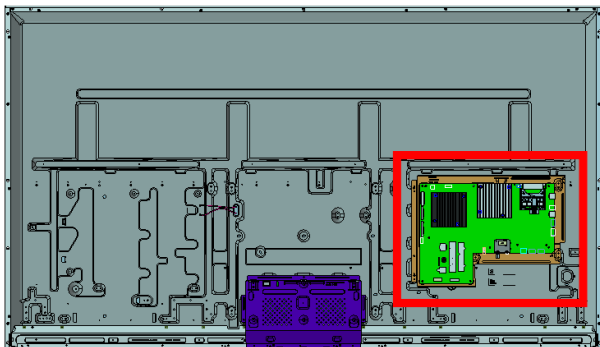

1

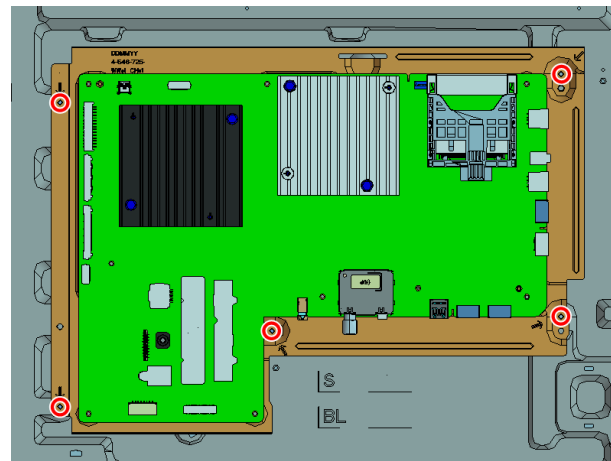

5 screws (SCREW, +PSW M3X8) P/N: 2-580-593-01

2

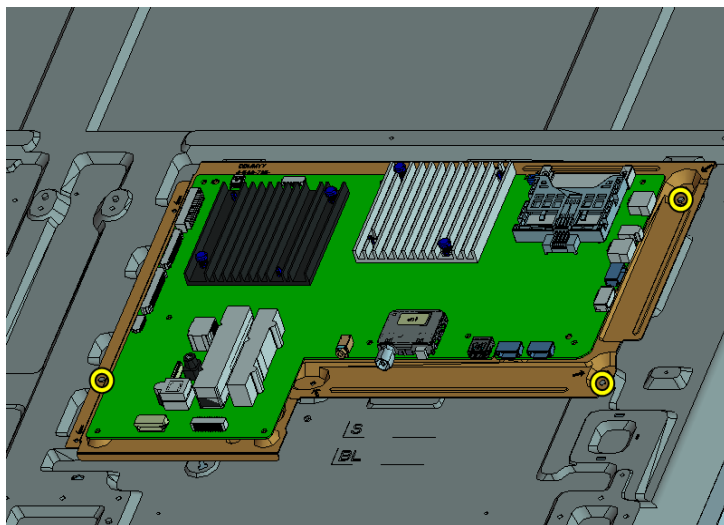

3

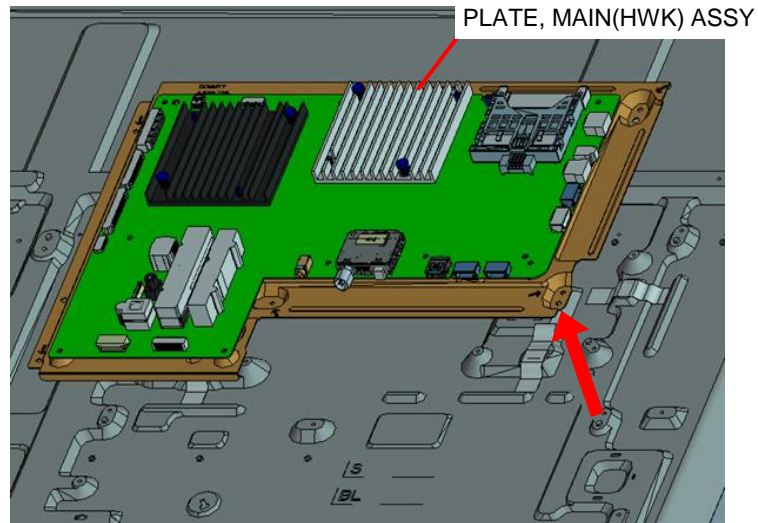

1-2. XBR-65X850C/855C/857C

1-2-29. BMFL ASSY

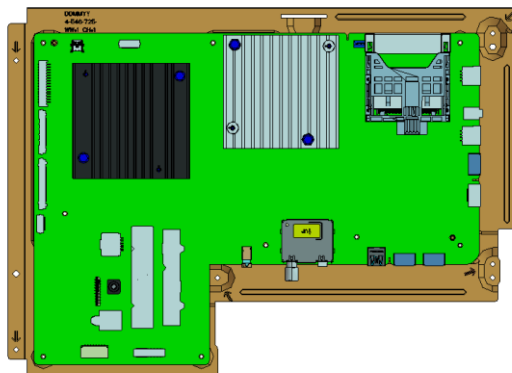

1

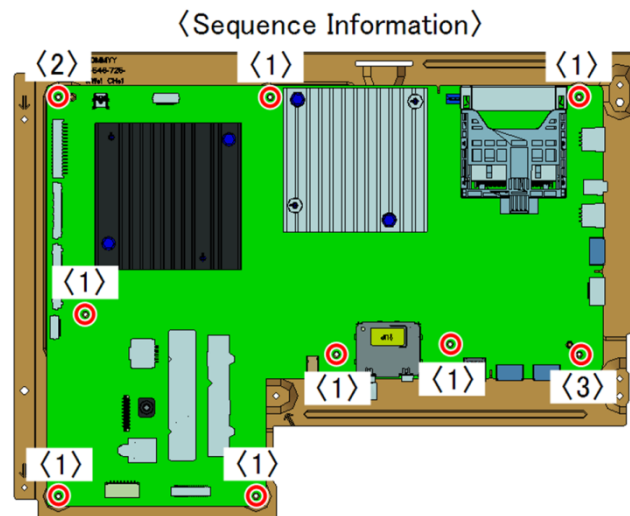

9 screws (SCREW (+PSW)(M3X6)) P/N: 2-990-421-41

2

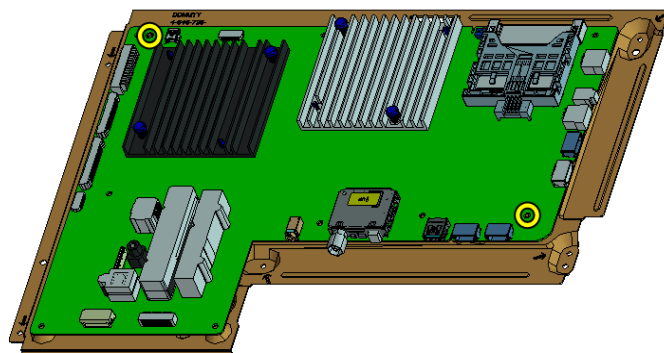

3

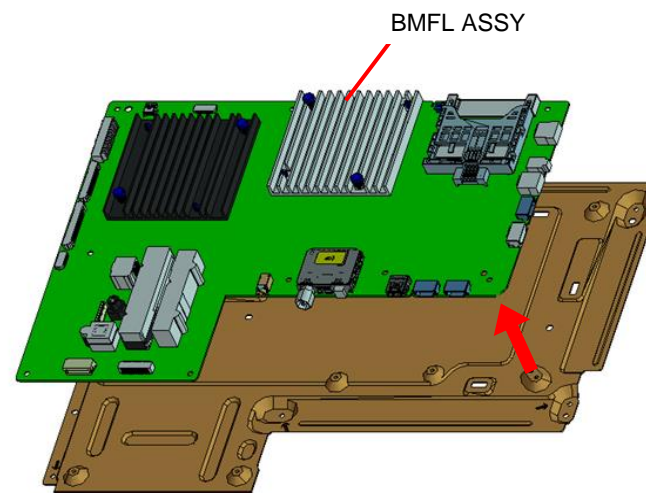

1-2. XBR-65X850C/855C/857C

1-2-30. GASKET (BMF)

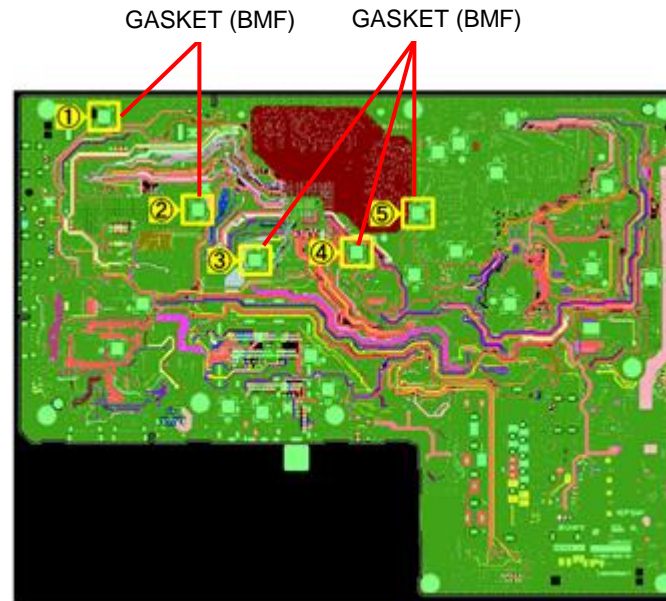
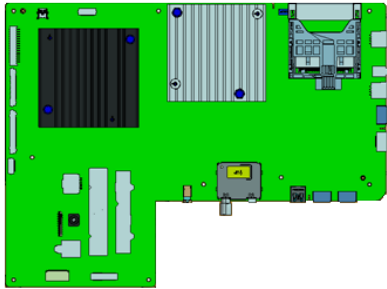

NOTE:

When you replace a BMFL board, it is necessary to stick five new GASKET on a new BMFL board.

GASKET (BMF): 4-566-117-01

Stick GASKET inside the guide line.

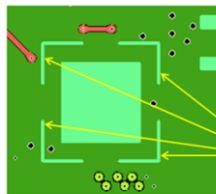

Guide line

*No indication of direction

Caution:

1. Please aim at the center of square land.
2. Assy the gaskets just before B board panel installation.

To stick the GASKET firmly,

Press the gasket until compression completely.

(0.5-1.0kgf)



1-2. XBR-65X850C/855C/857C

1-2-31. SHEET, THERMAL(BM) AND PLATE, MAIN(HWK)

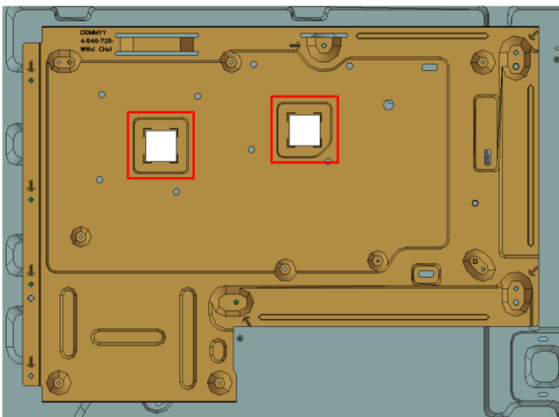

1

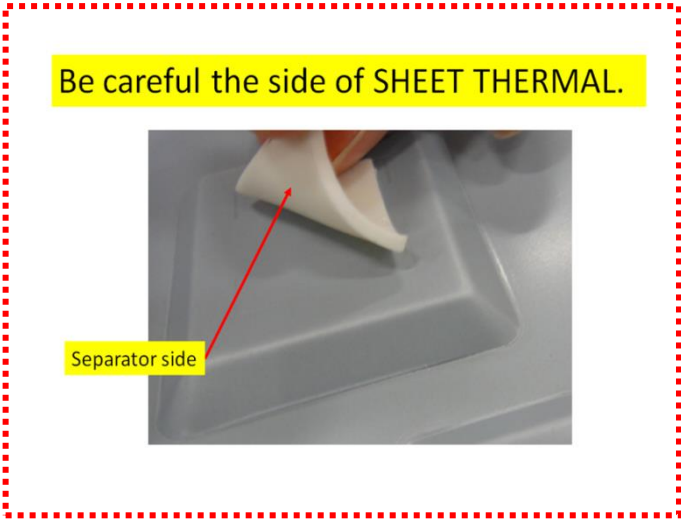
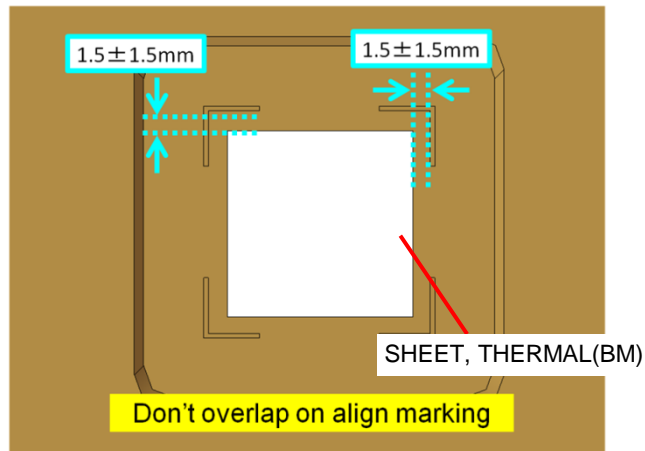

2

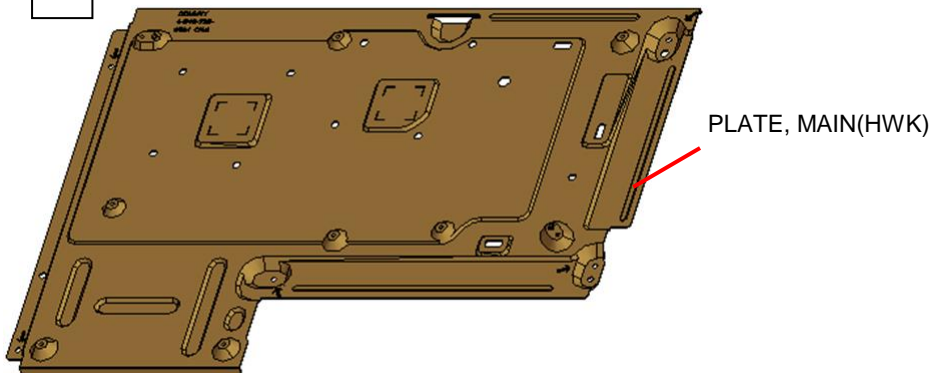

1-2. XBR-65X850C/855C/857C

1-2-32. CUSHION, CORNER(EGL) AND TAPE

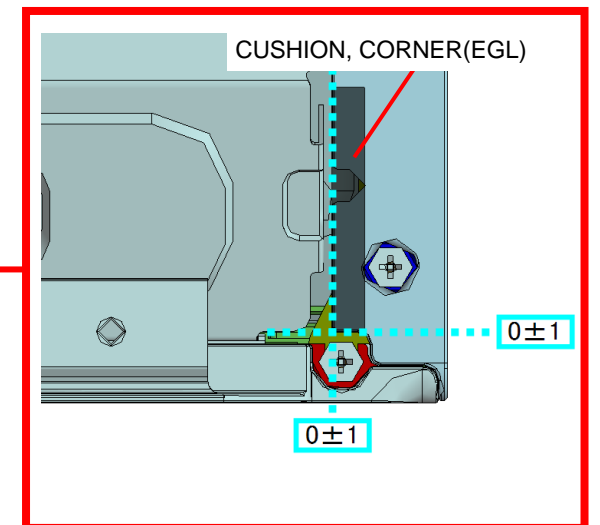
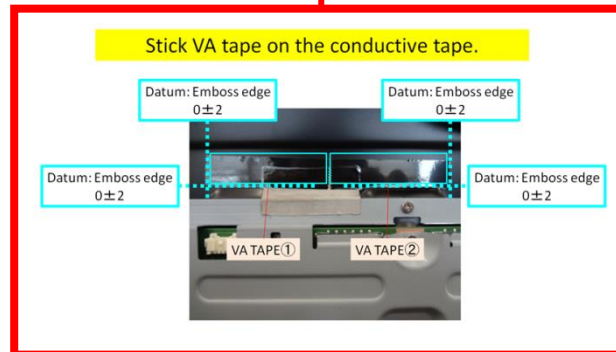
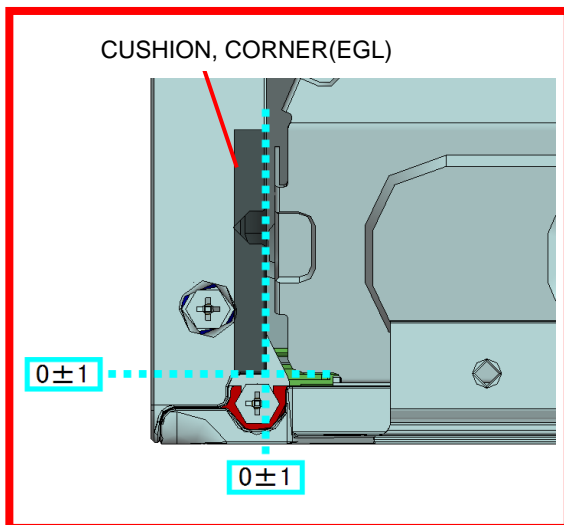
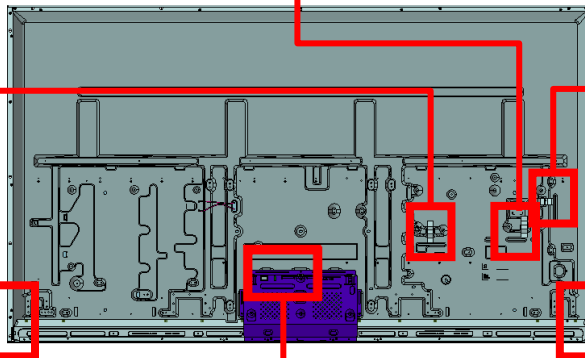
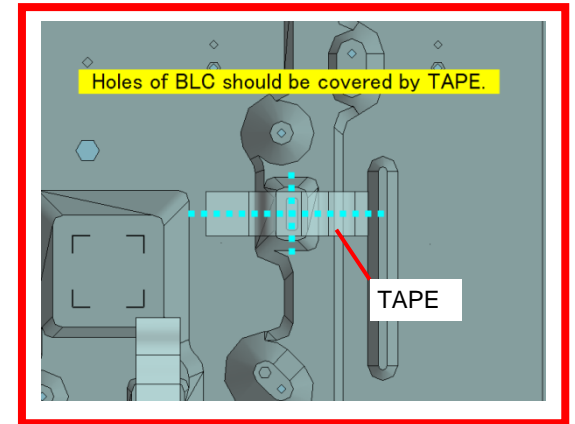
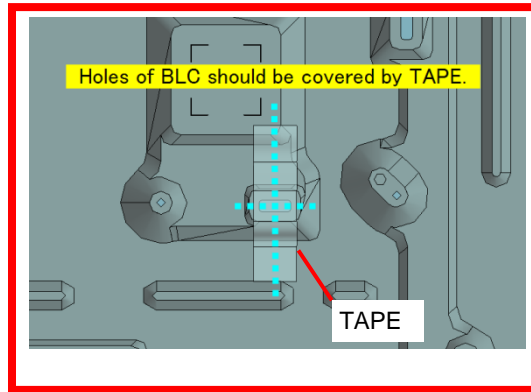
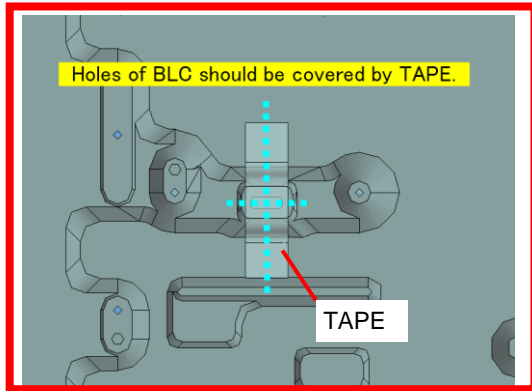

1-2. XBR-65X850C/855C/857C

1-2-33. LCD PANEL

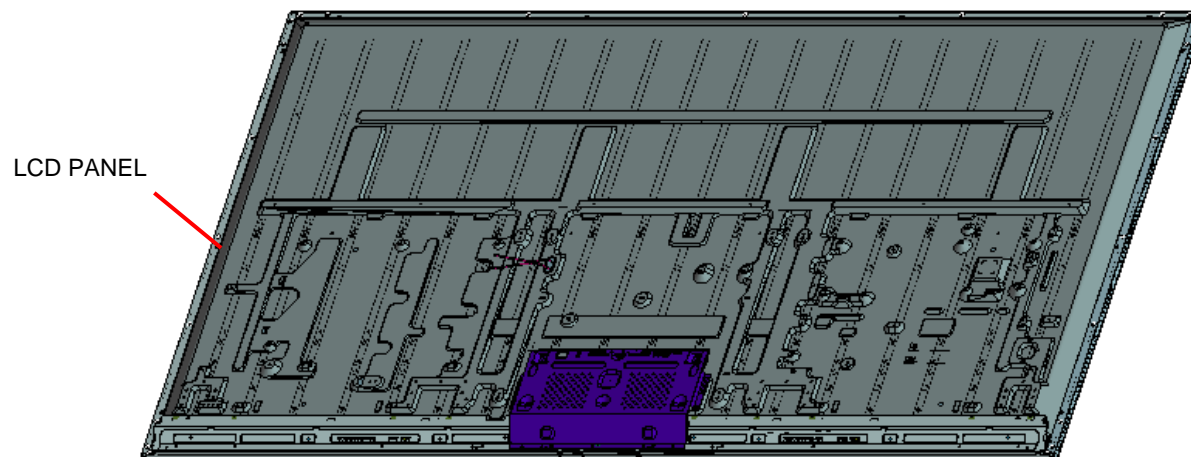

1-3. XBR-75X850C/855C

1-3-1. STAND

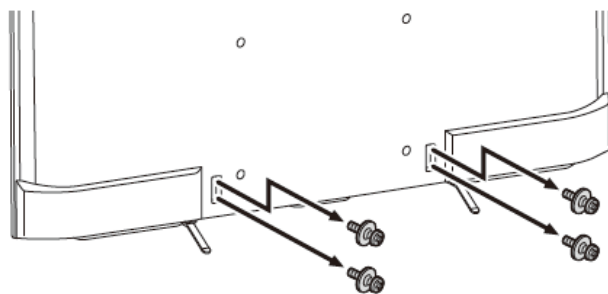

4 screws (SCREW, +PSW M6X12) P/N: 4-567-081-01

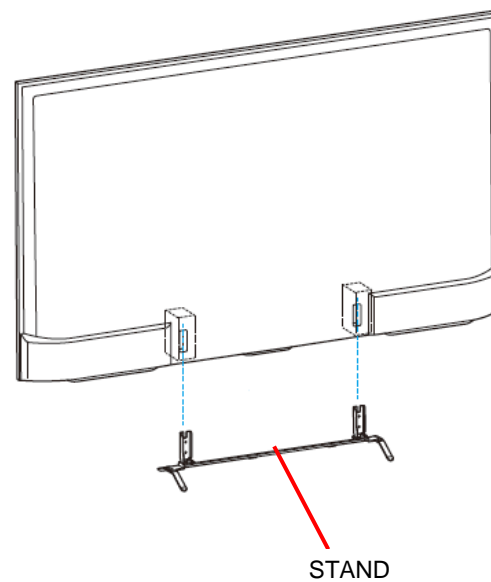

1-3. XBR-75X850C/855C

1-3-2. LABEL, UNDER TERMINAL AND LABEL, REAR TERMINAL AND LABEL, SIDE TERMINAL (L)

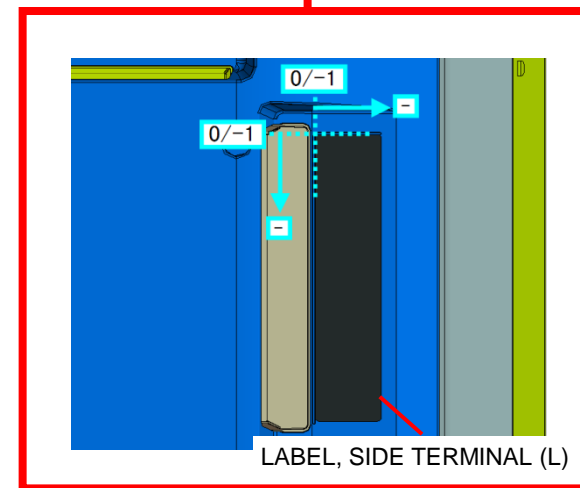
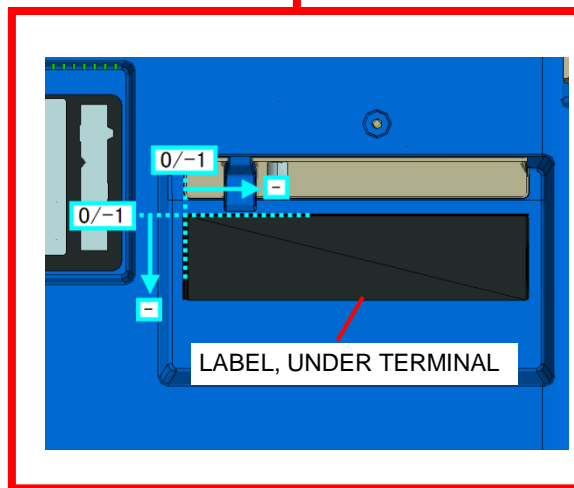
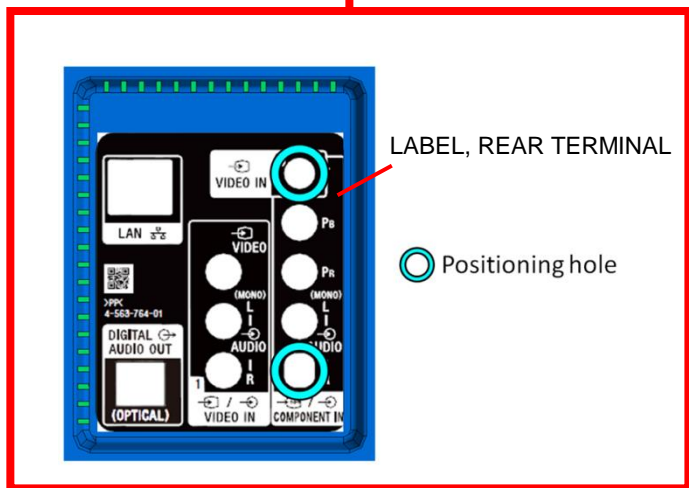
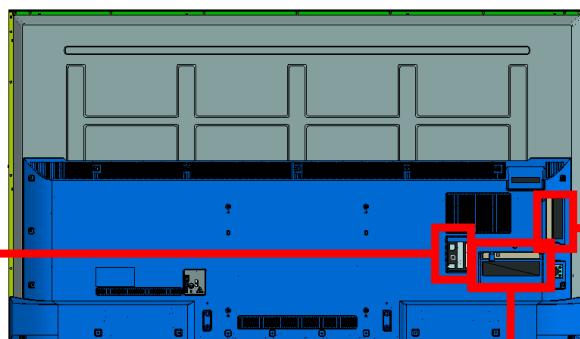

1-3. XBR-75X850C/855C

1-3-3. AC COVER AND POWER SUPPLY CORD

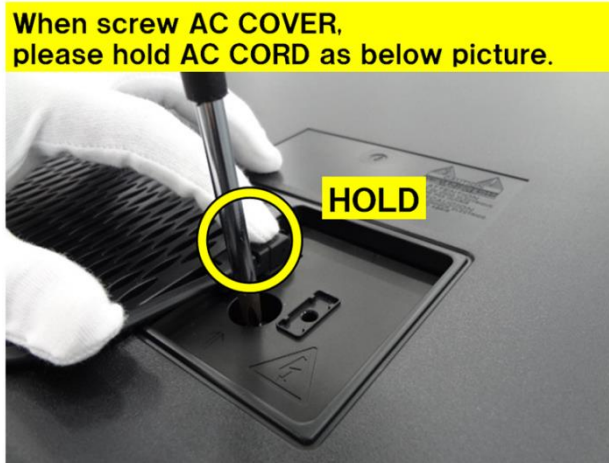
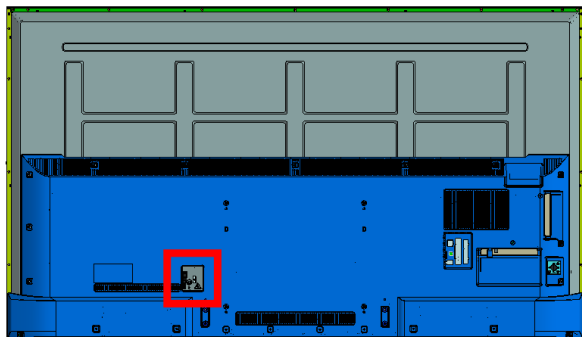

1

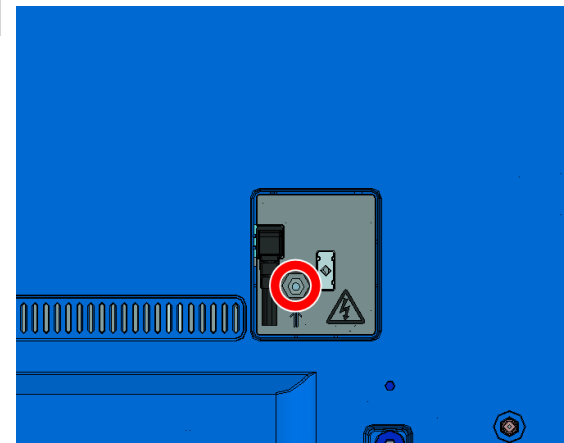

Screw (SCREW +PSW M4X10) P/N: 4-159-298-01

2

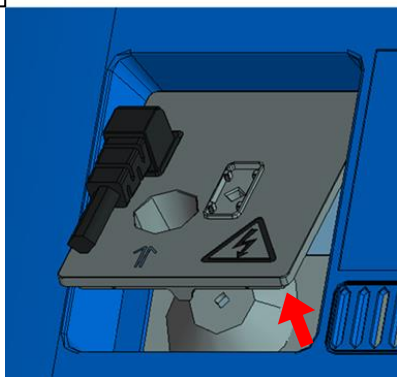

3

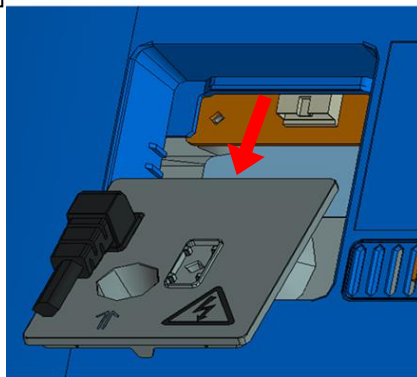

4

POWER SUPPLY CORD

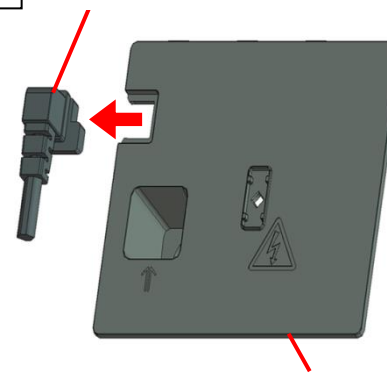

AC COVER

5

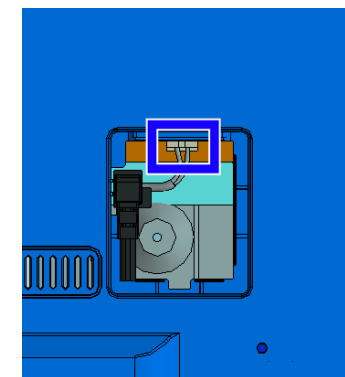

1-3. XBR-75X850C/855C

1-3-4. UNDER COVER (3L_HWK) A

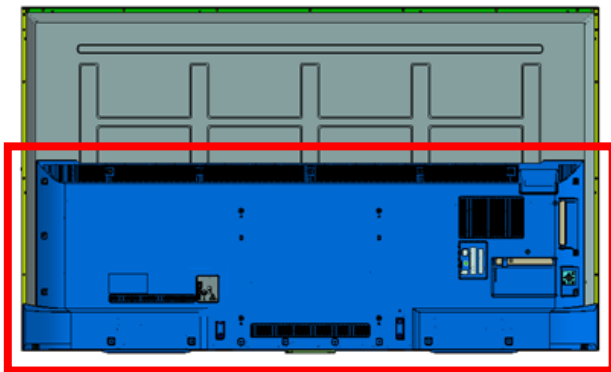

1

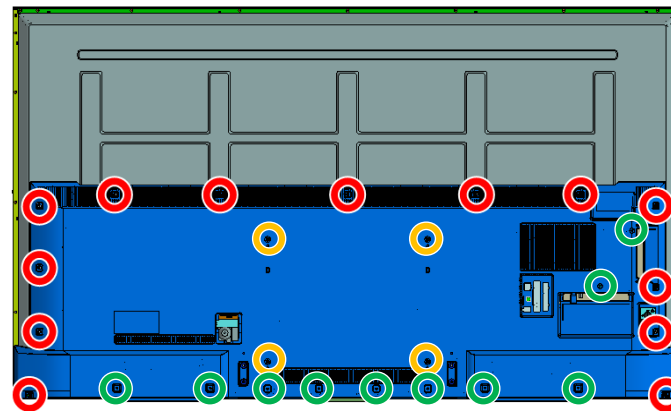

- 13 screws (SCREW , +PWH M3X6) P/N: 4-452-935-11
- 4 screws (SCREW, ORNAMENTAL M6X12) P/N: 4-268-126-02
- 10 screws (SCREW, +BVTP 4X12 TYPE2 IT-3) P/N: 2-580-639-01

2



Ensure R/C is installed to slit of panel.

OK

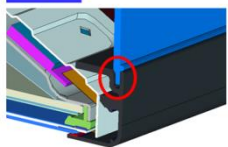

Bottom side

NG



Bottom side

3

UNDER COVER (3L_HWK) A



1-3. XBR-75X850C/855C

1-3-5. TAPE

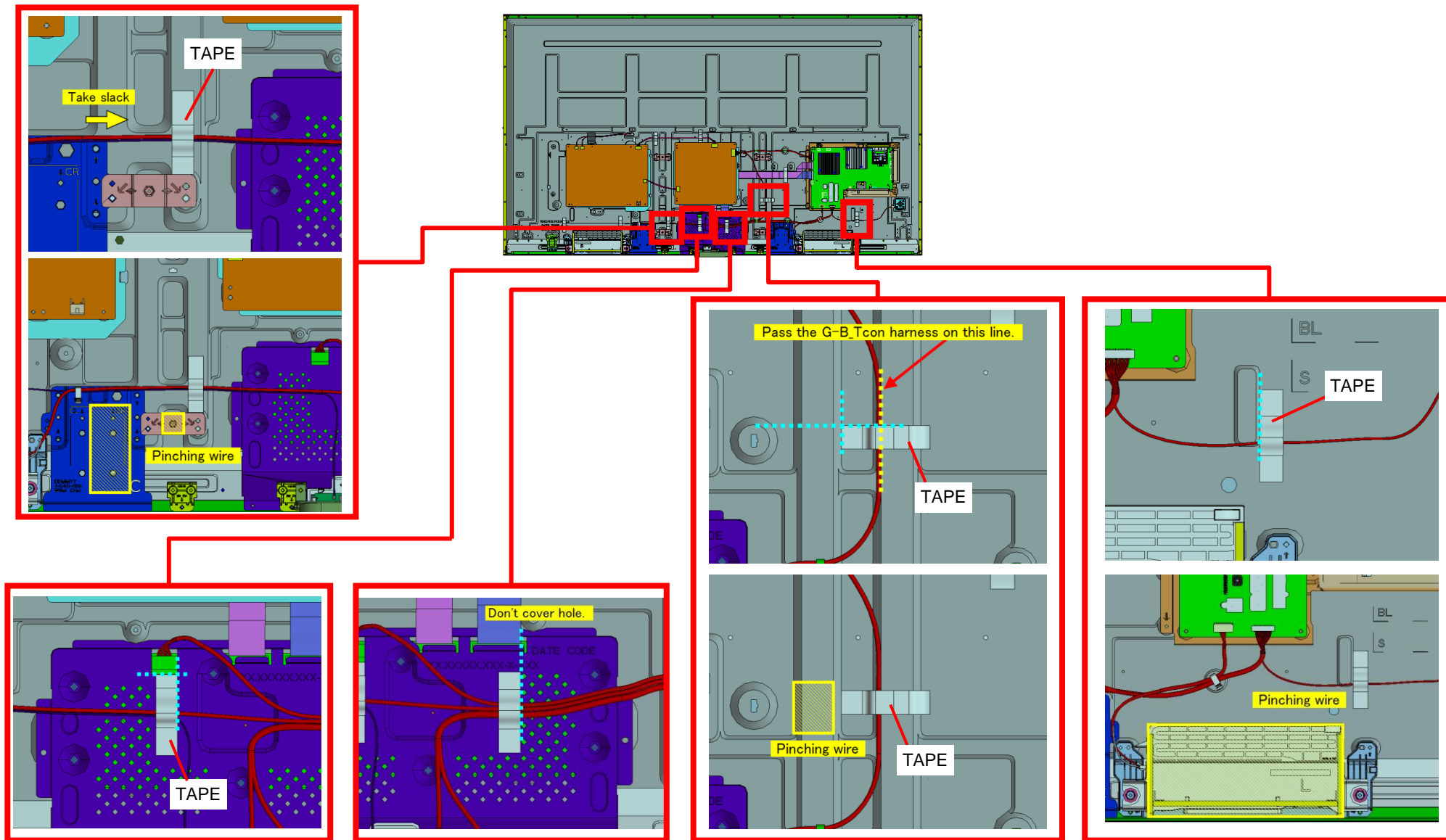

1-3. XBR-75X850C/855C

1-3-6. TAPE

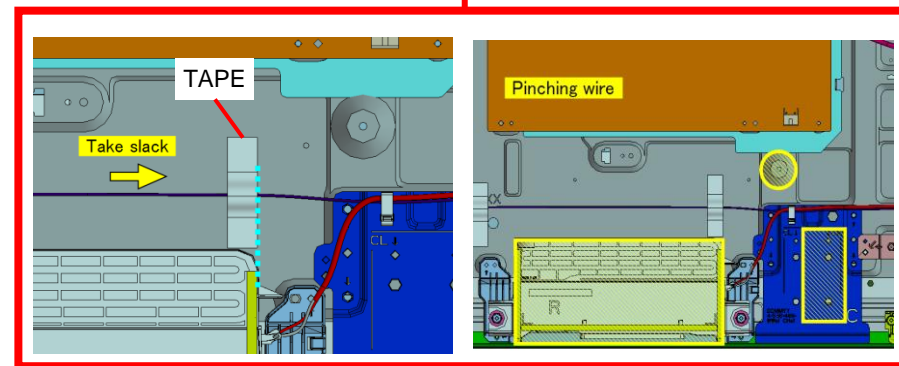
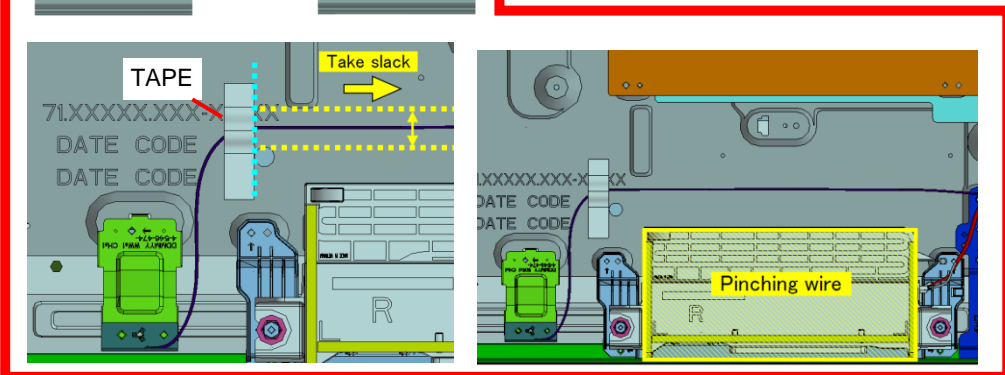
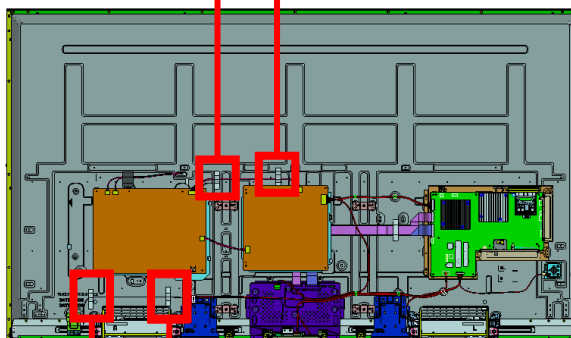
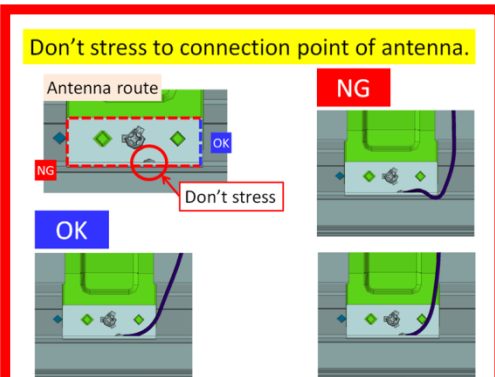
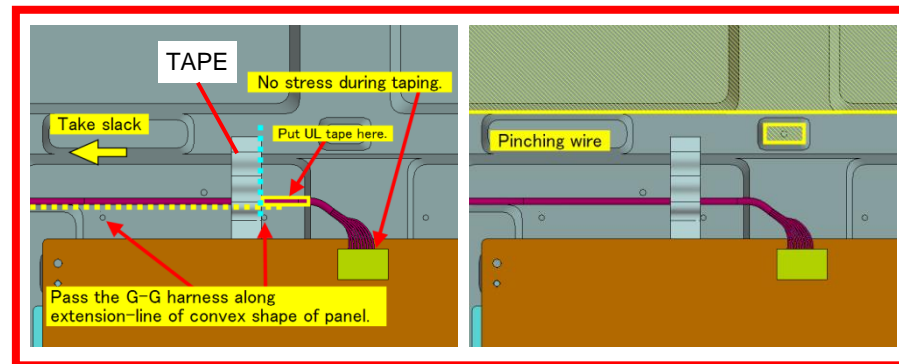
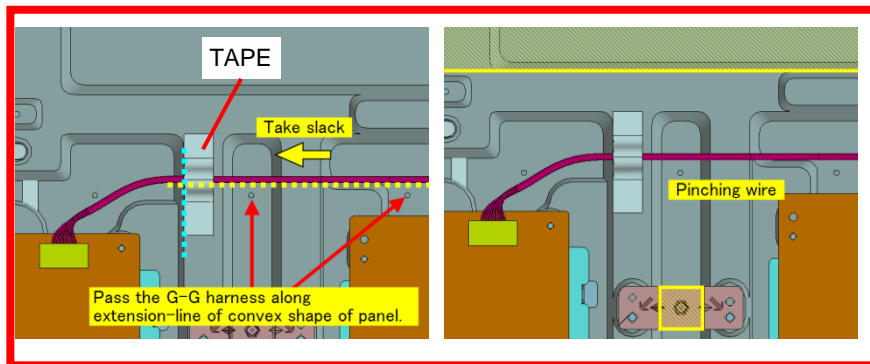

1-3. XBR-75X850C/855C

1-3-7. WIRE DRESSING

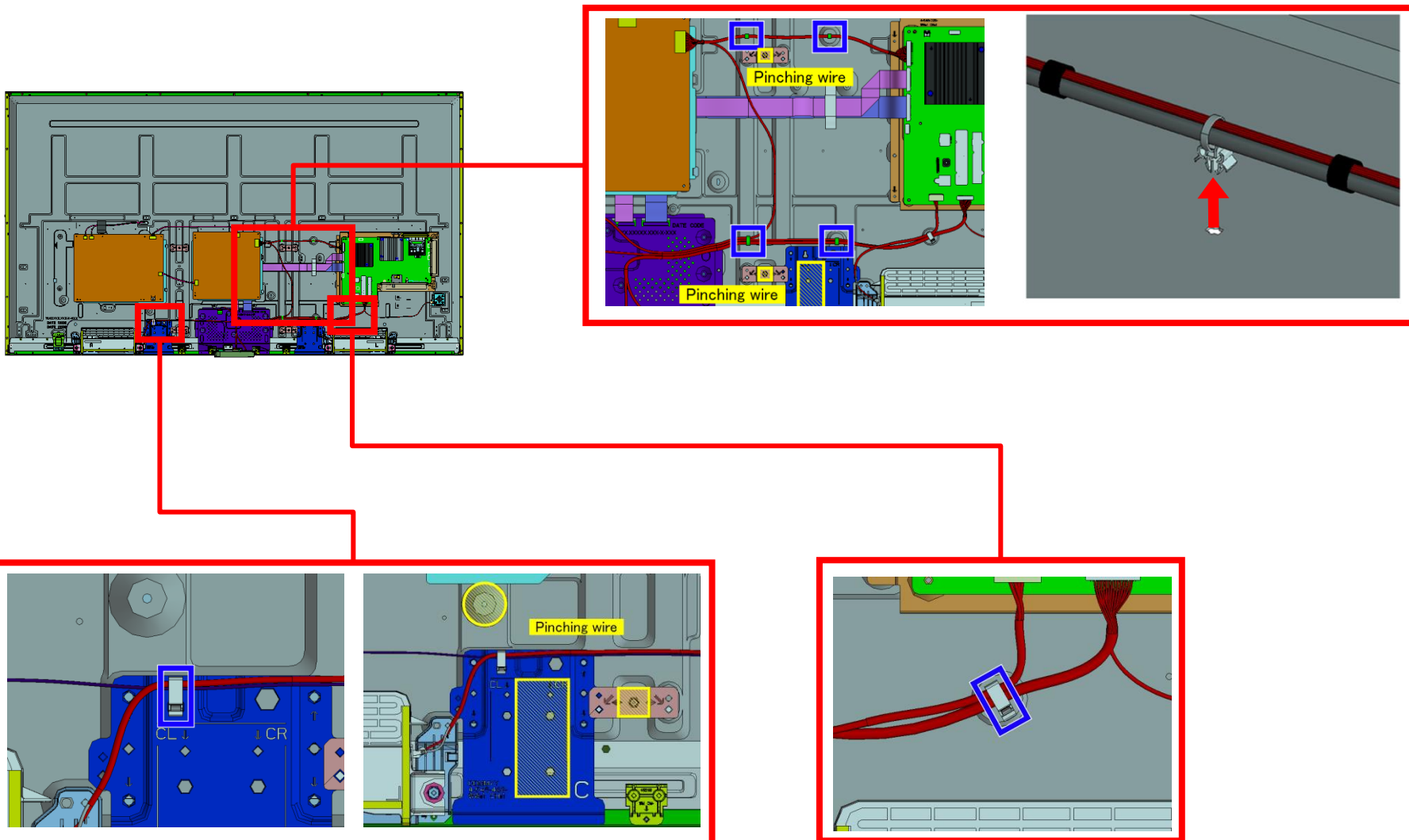

1-3. XBR-75X850C/855C

1-3-8. SPEAKER BOX ASSY (L)

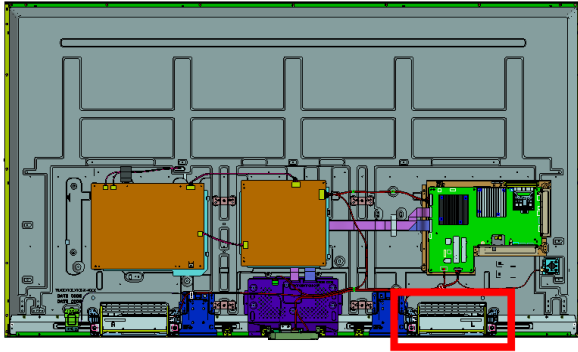

1

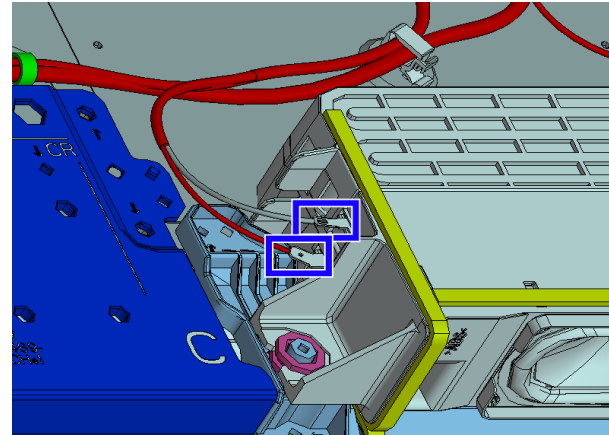

2

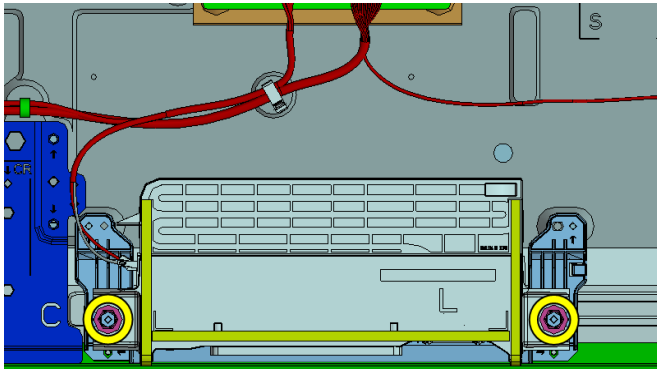

3

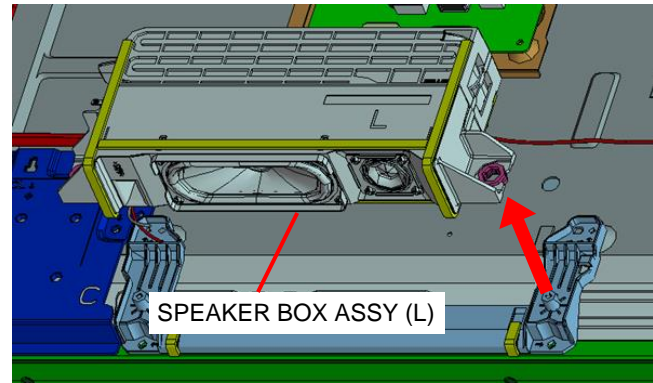

1-3. XBR-75X850C/855C

1-3-9. BRACKET, SP (2L HWK) A

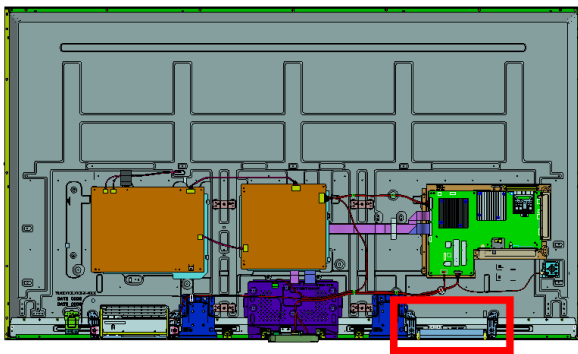

1

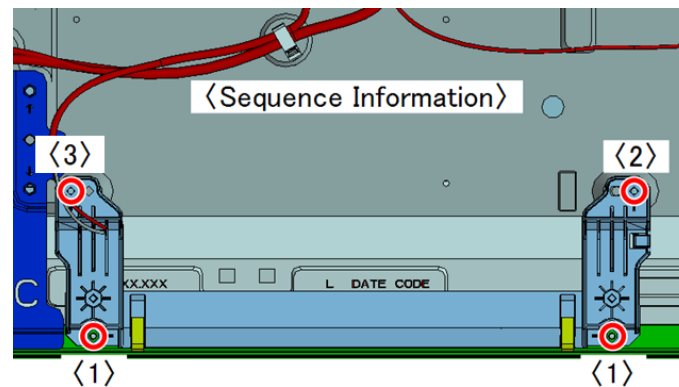

4 screws (SCREW , +PSW M3X8) P/N: 2-580-593-01

2

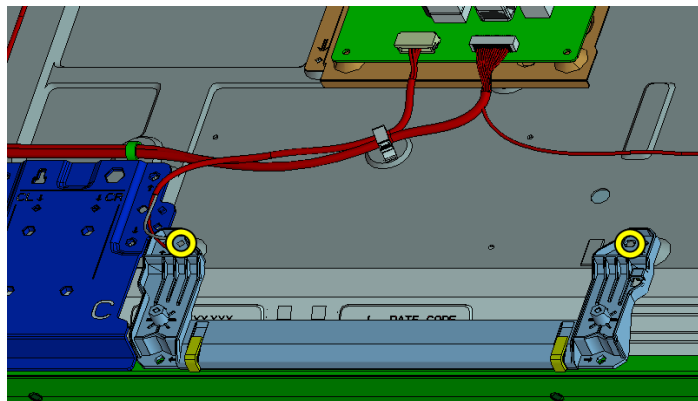

3

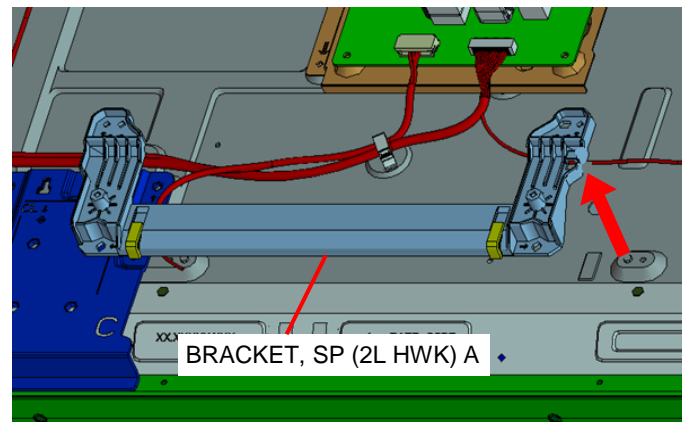

1-3. XBR-75X850C/855C

1-3-10. SPEAKER BOX ASSY (R)

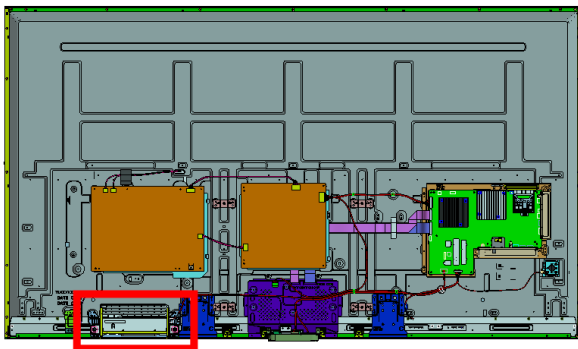

1

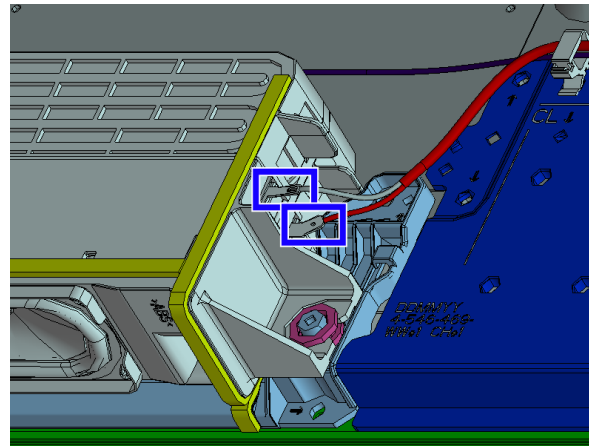

2

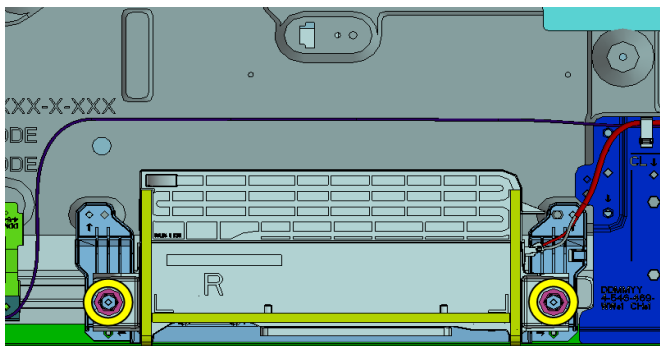

3

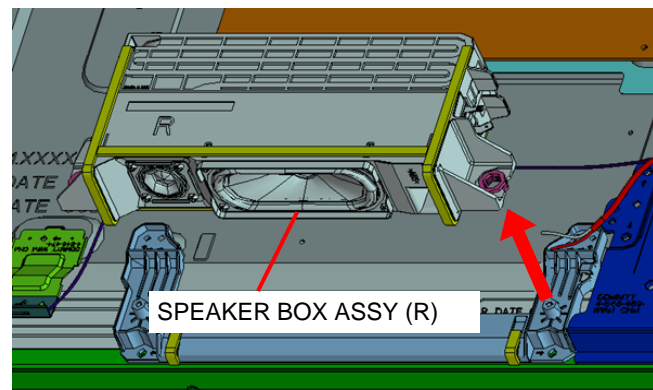

1-3. XBR-75X850C/855C

1-3-11. BRACKET, SP (2L HWK) A

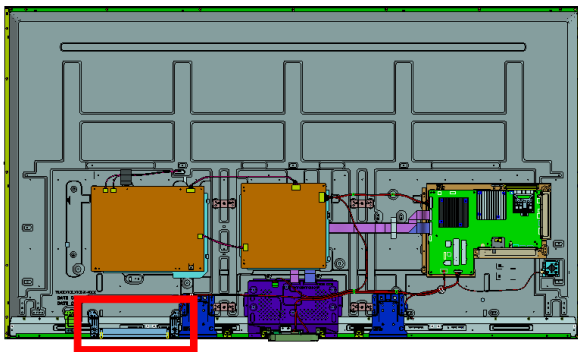

1

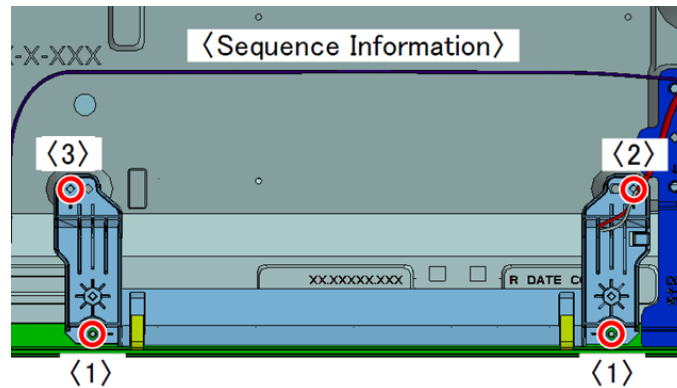

4 screws (SCREW , +PSW M3X8) P/N: 2-580-593-01

2

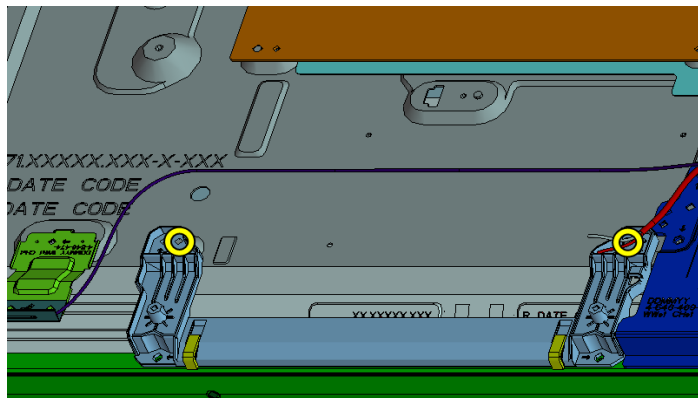

3

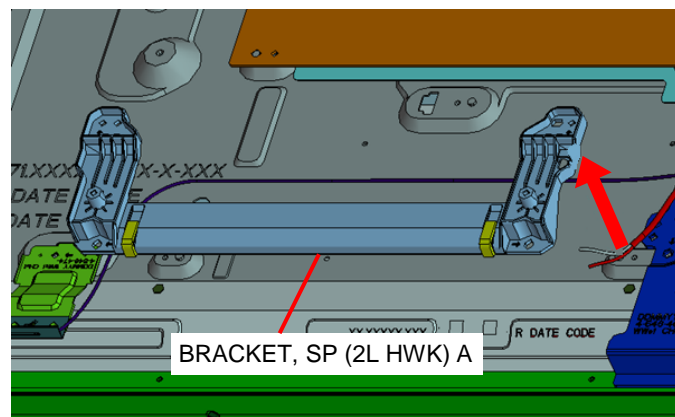

1-3. XBR-75X850C/855C

1-3-12. BRACKET,BT (EGL) ASSY

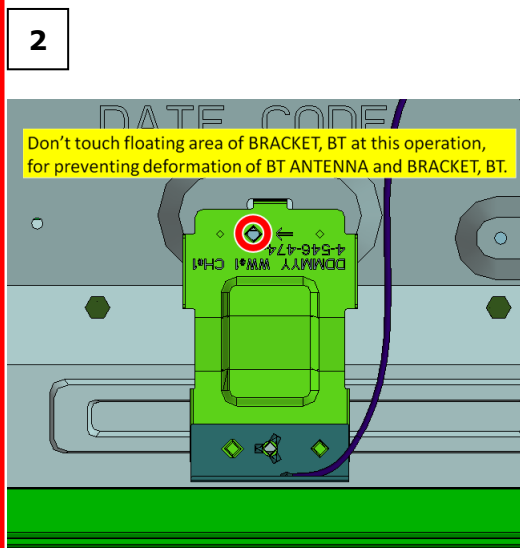
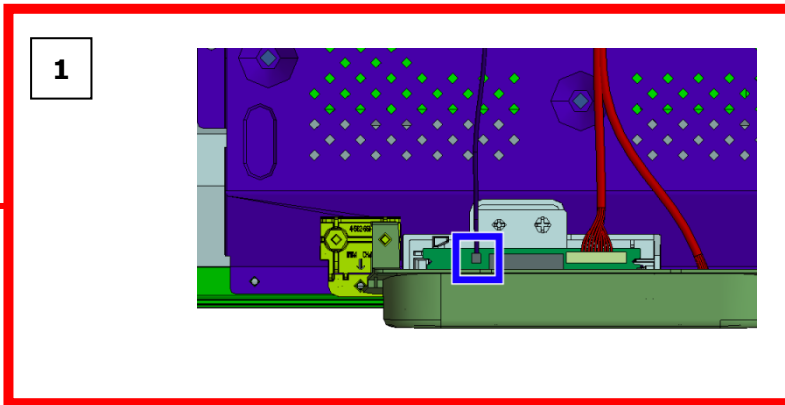
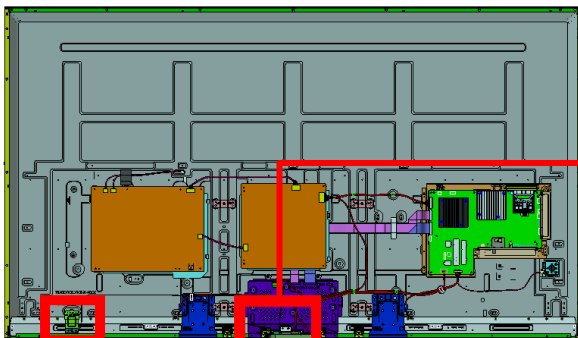

Screw (SCREW (+PSW)(M3X6))
P/N: 2-990-421-41

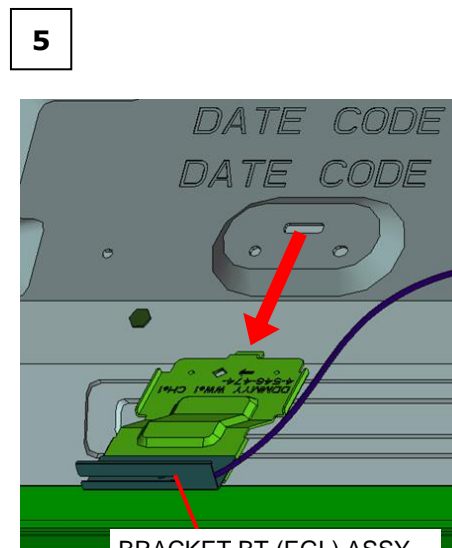
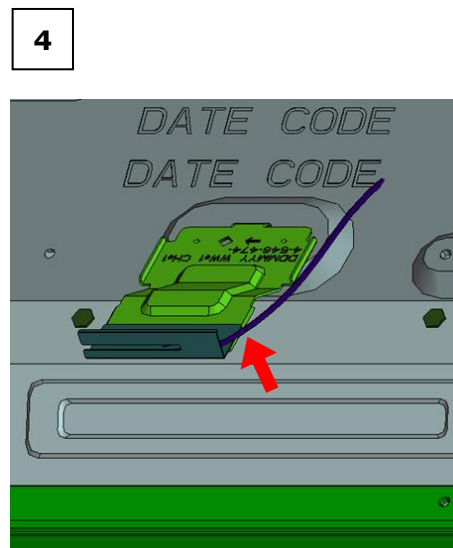
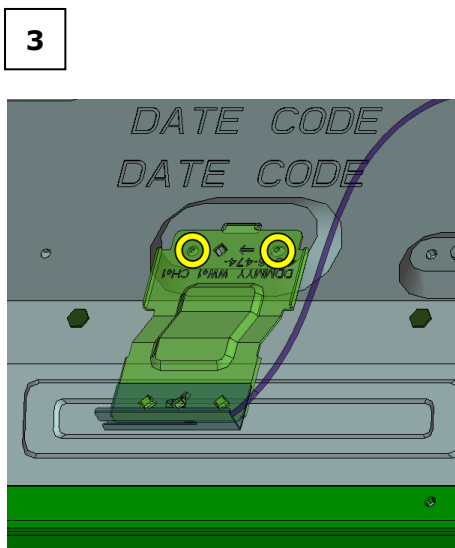

BRACKET,BT (EGL) ASSY

1-3. XBR-75X850C/855C

1-3-13. BT ANTENNA/WIFI ANTENNA AND BRACKET, BT(EGL)

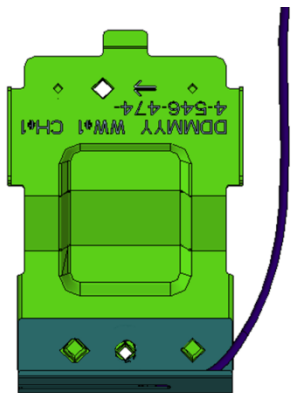

1

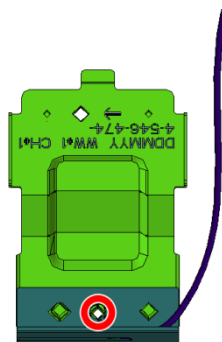

Screw (SCREW (+PSW))(M3X6)
P/N: 2-990-421-41

2

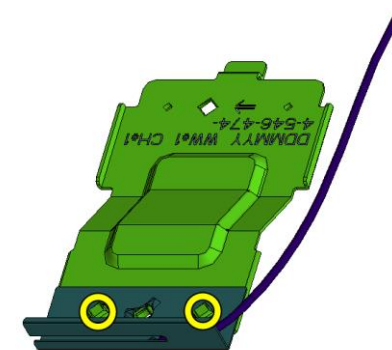

3

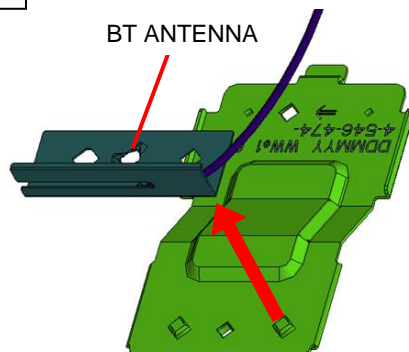

4

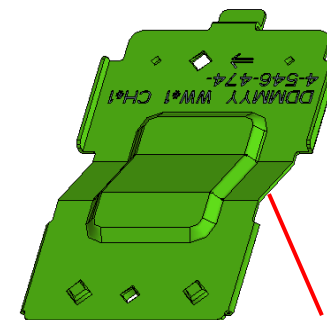

BRACKET,BT (EGL)

1-3. XBR-75X850C/855C

1-3-14. SMART CORE

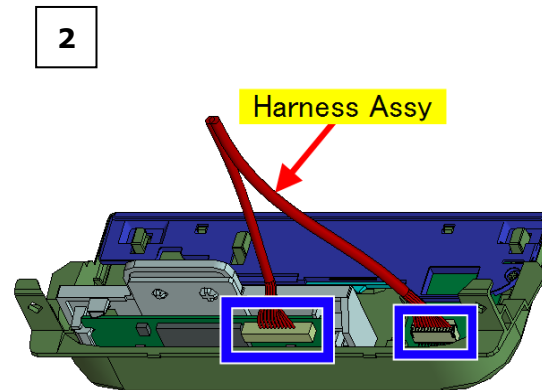
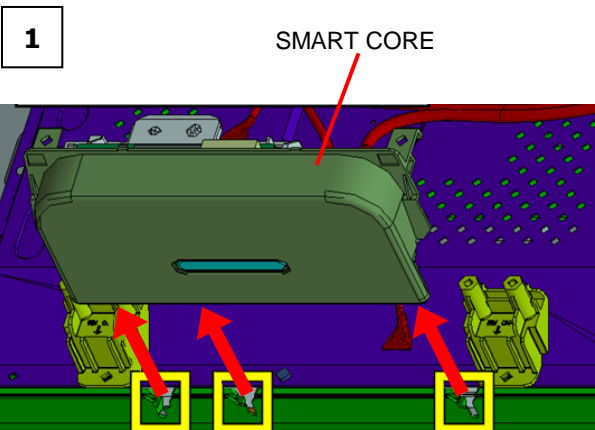
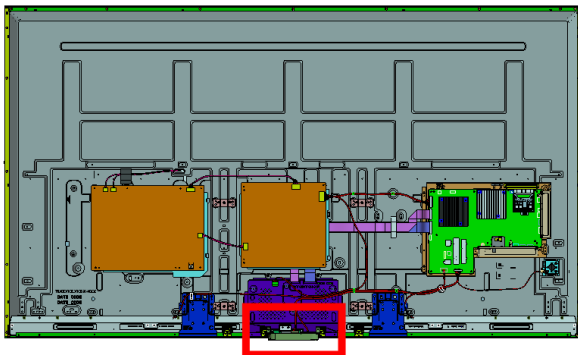

Notes on assembling the Smart core

Don't scratch O/P with Bezel while installing.

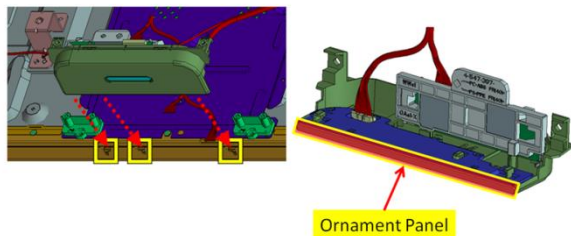

No gap between Smart Core and AL Bezel.

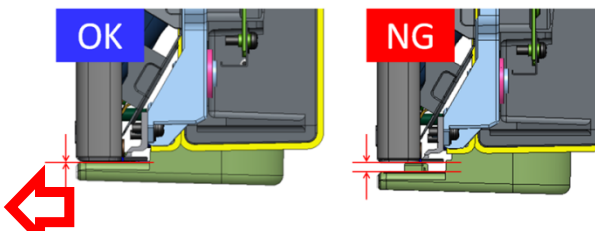

Front View of the TV

Don't touch these components while installing.

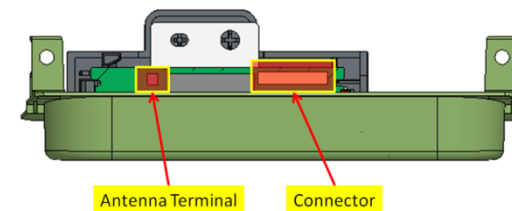

1-3. XBR-75X850C/855C

1-3-15. SWITCH UNIT

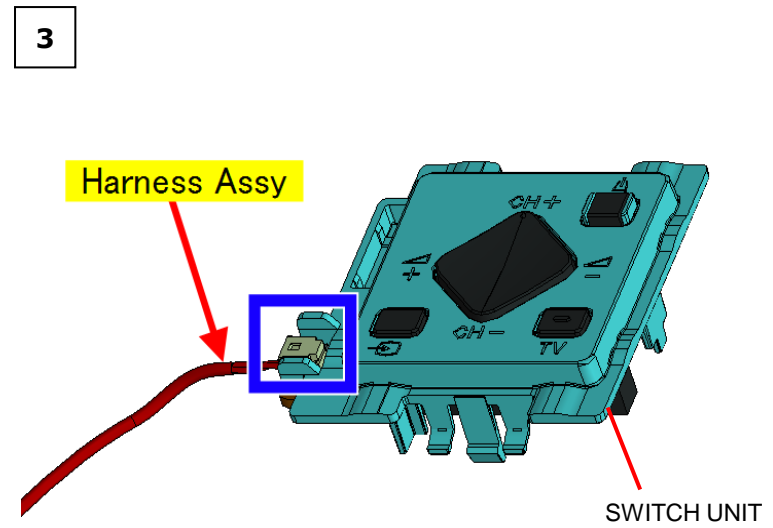
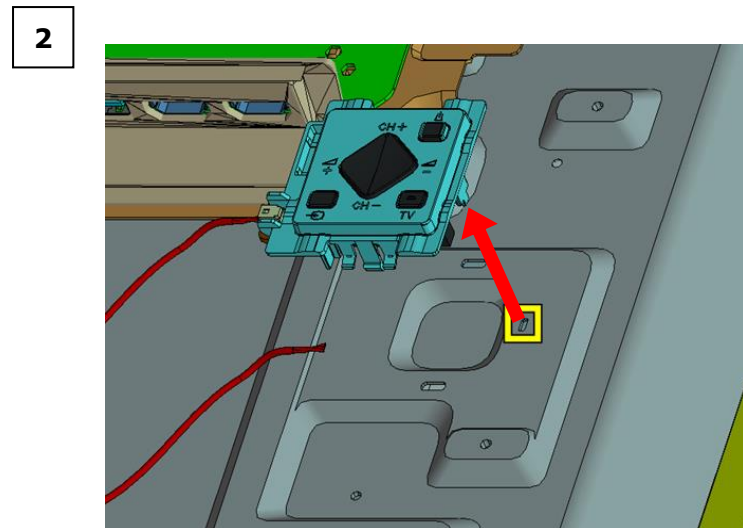
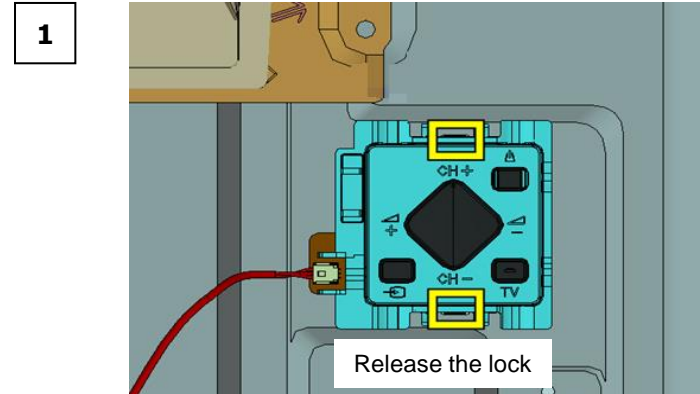
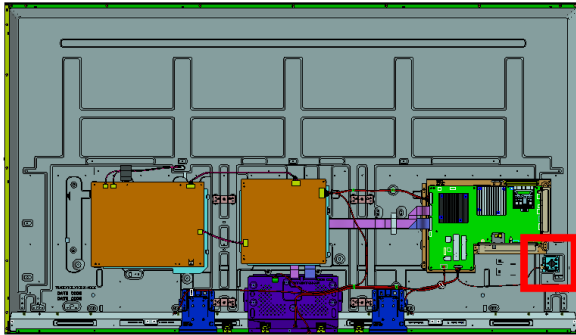

1-3. XBR-75X850C/855C

1-3-16. HARNESS ASSY (GBT / MAIN) AND CONNECTOR ASSY, 3P AND CONNECTOR ASSY 9P

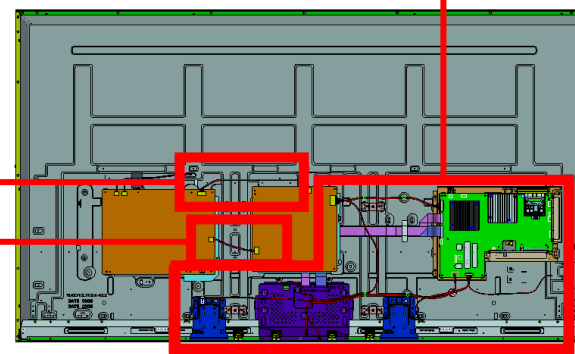
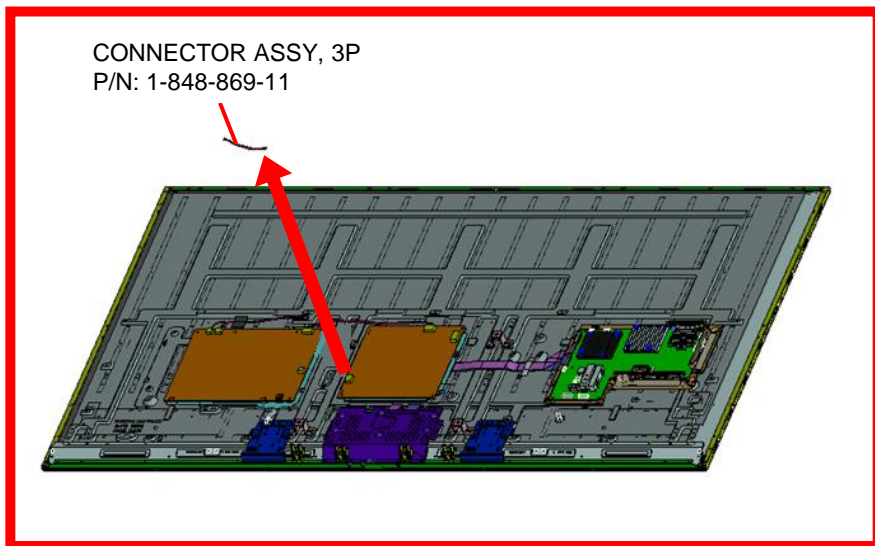
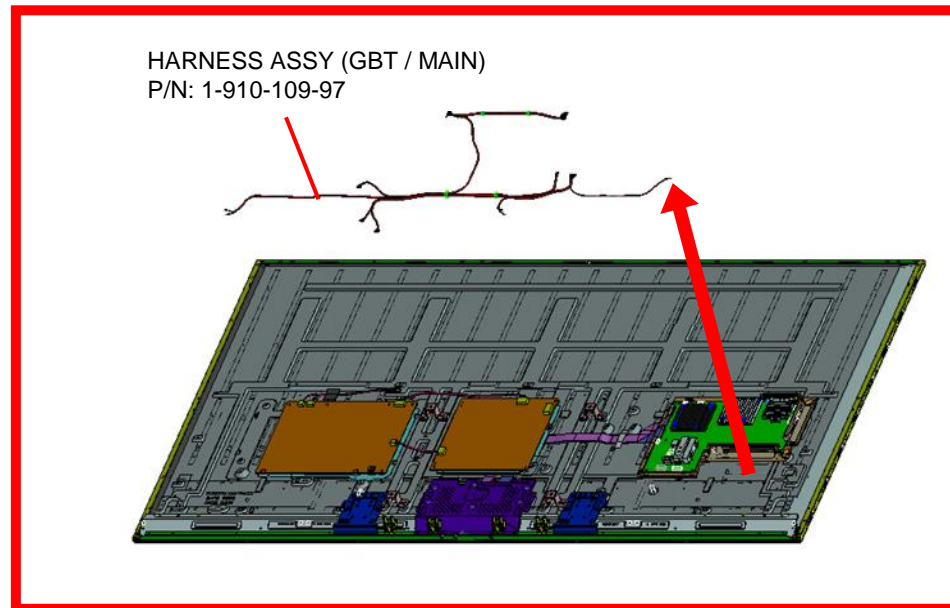
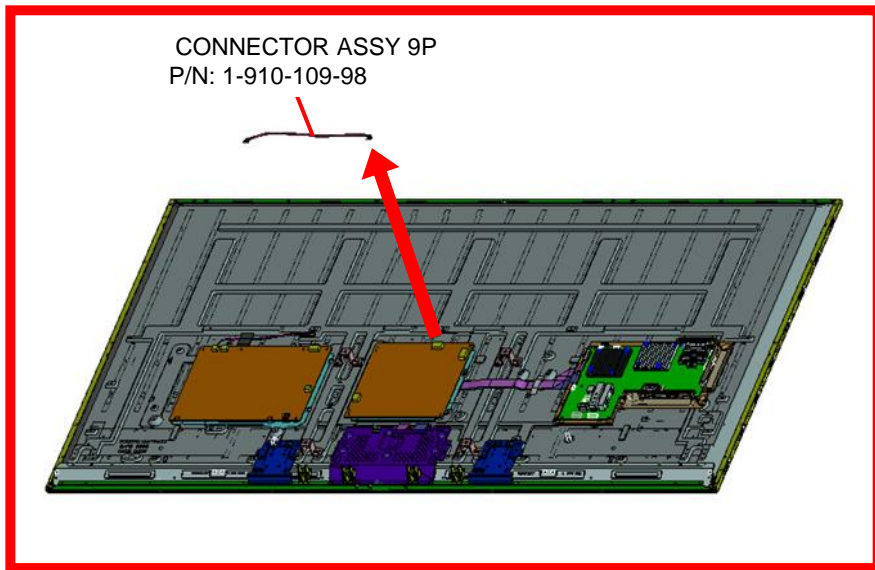

1-3. XBR-75X850C/855C
1-3-17. BRACKET,VESA(HWK)

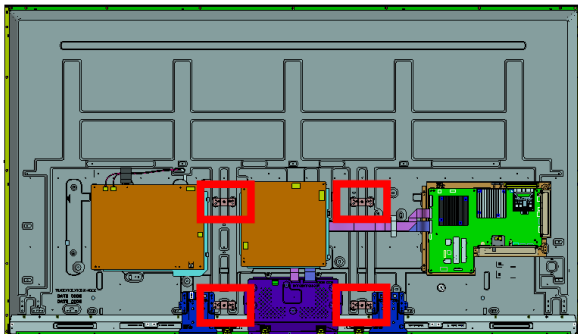

1

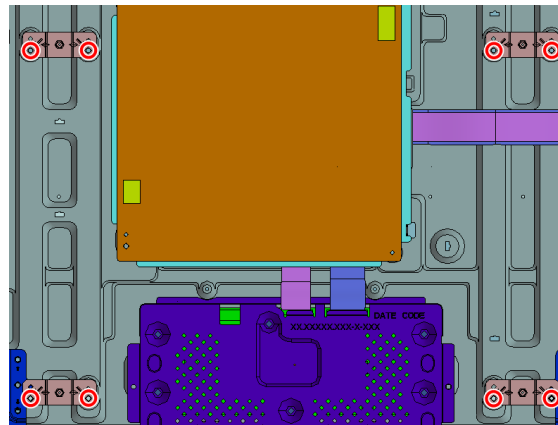

8 screws (SCREW, +PSW M4X8) P/N: 2-580-600-11

2

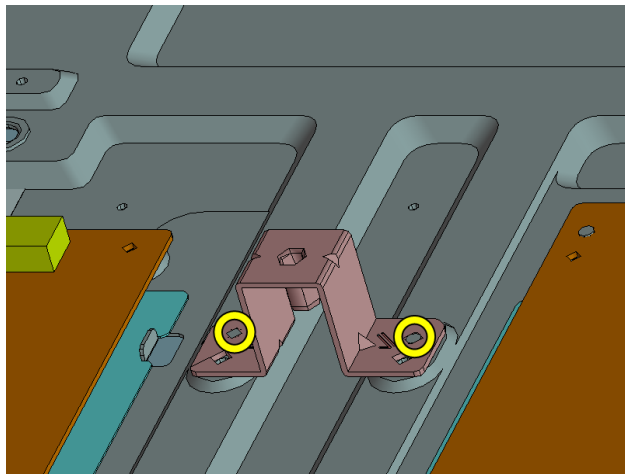

3

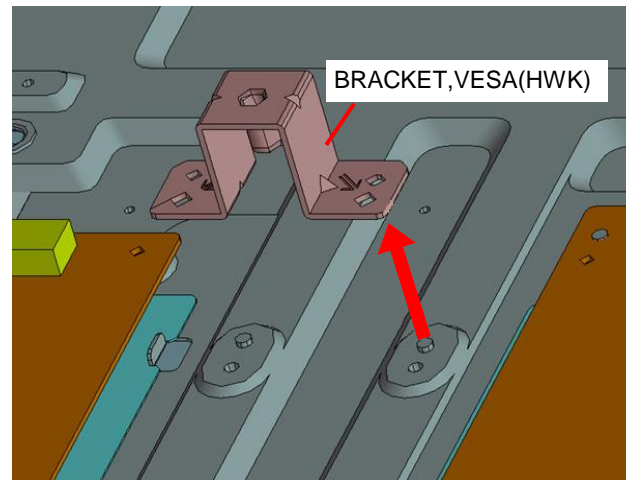

1-3. XBR-75X850C/855C

1-3-18. BRACKET, SC(HWK)

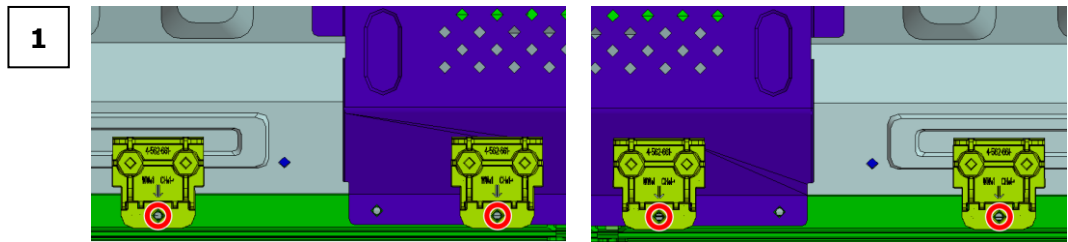
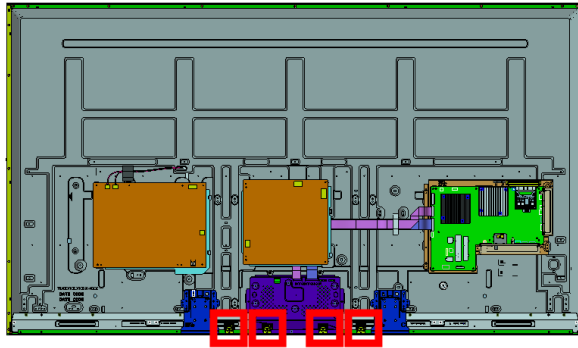

4 screws (SCREW, +PSW M3X8) P/N: 2-580-593-01

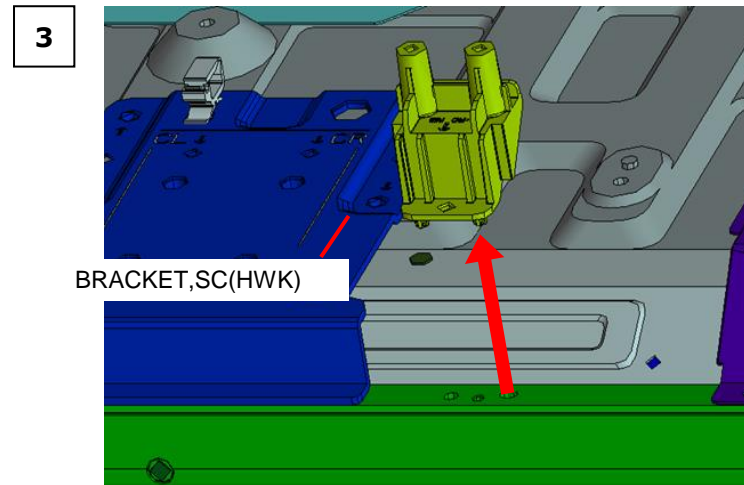
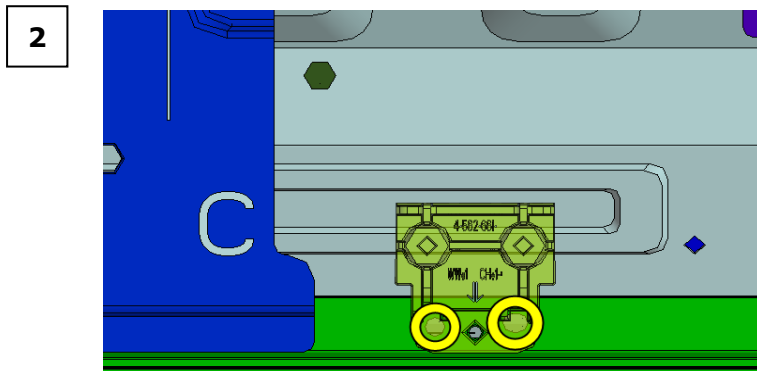

1-3. XBR-75X850C/855C

1-3-19. SLIDE, CLAMP

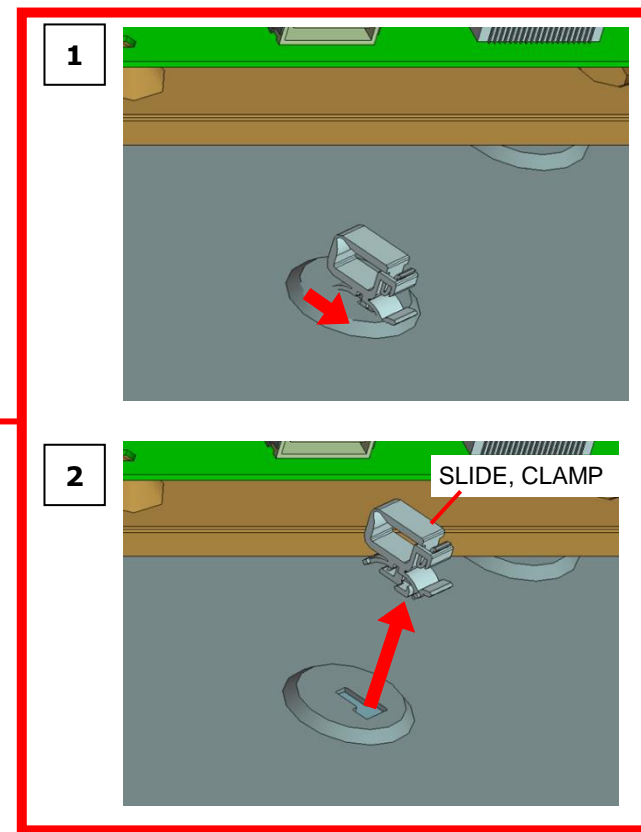
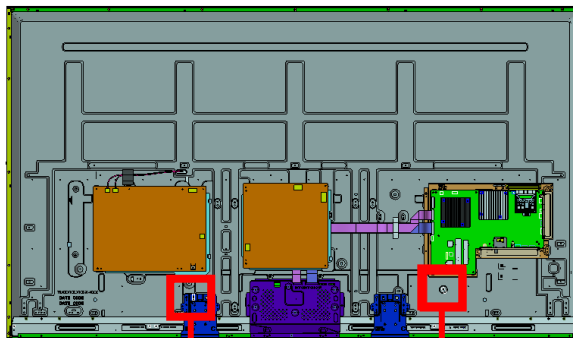
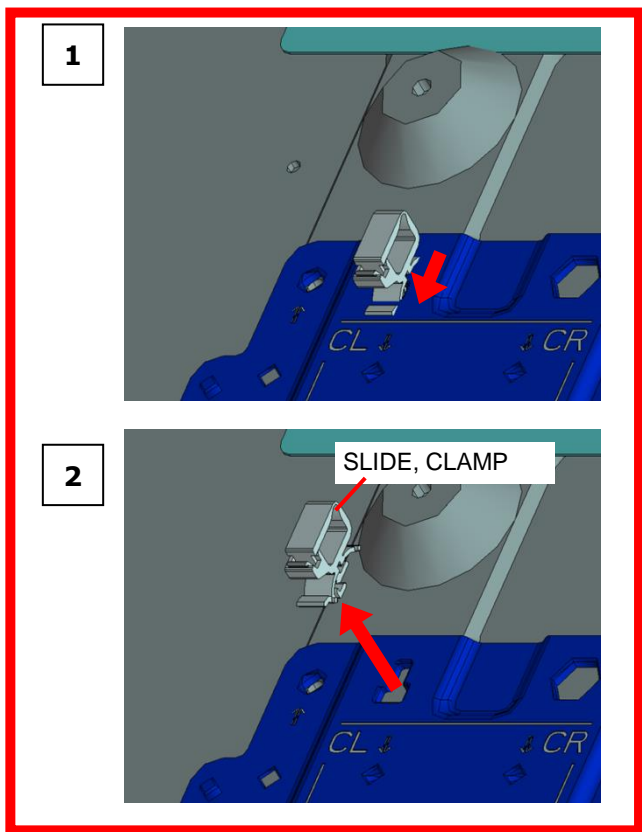

1-3. XBR-75X850C/855C

1-3-20. BRACKET, STD C (2L_HWK)

1

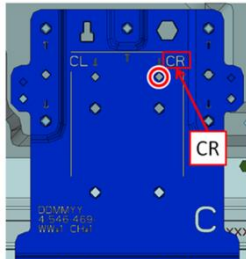

Screw (PULLEY, STAND (HWI)) P/N: 4-534-964-01

2

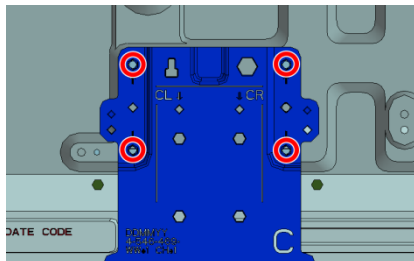

4 screws (SCREW, +PSW M4X8) P/N: 2-580-600-11

3

BRACKET, STD C(2L_HWK)

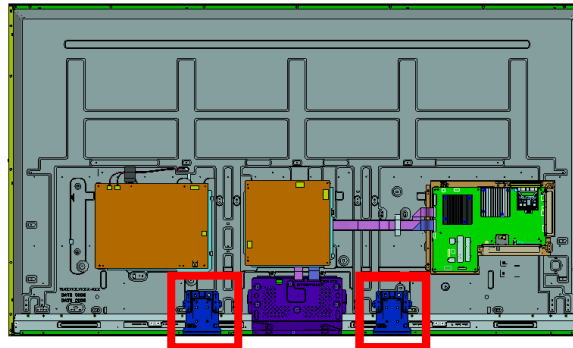
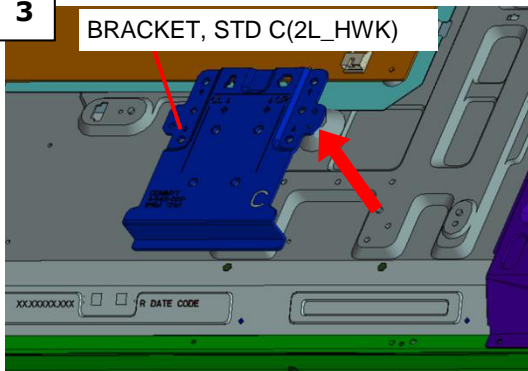

1

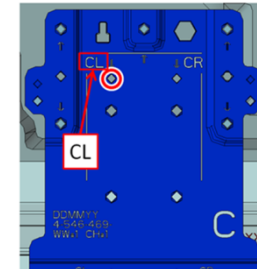

Screw (PULLEY, STAND (HWI)) P/N: 4-534-964-01

2

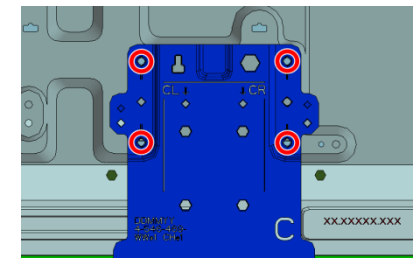

4 screws (SCREW, +PSW M4X8) P/N: 2-580-600-11

3

BRACKET, STD C(2L_HWK)

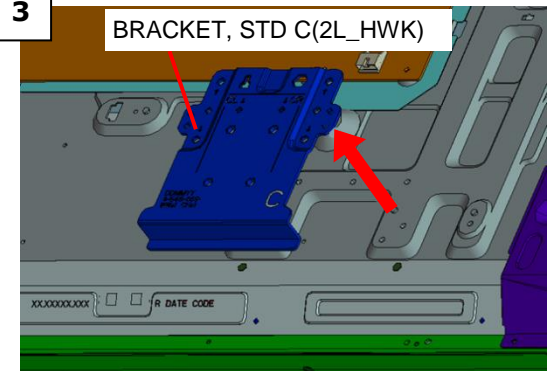

1-3. XBR-75X850C/855C

1-3-21. G4-STATIC CONVERTER(TV)

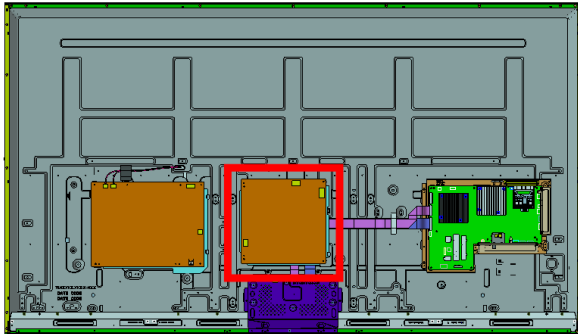

1

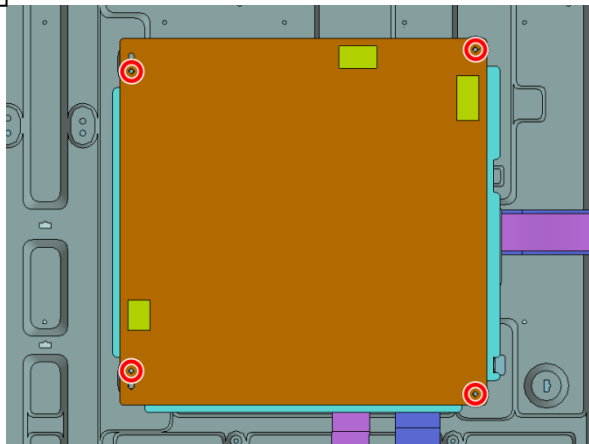

4 screws (SCREW, +PSW M3X6 W12) P/N: 4-256-393-11

2

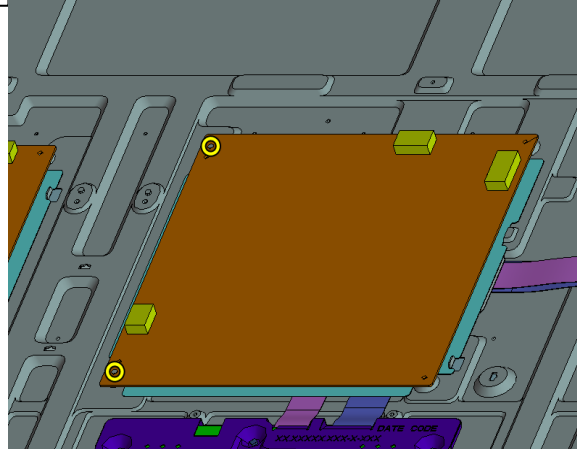

3

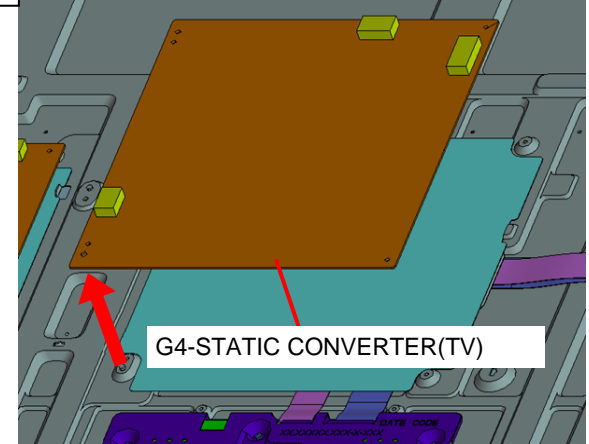

1-3. XBR-75X850C/855C

1-3-22. SHEET, INSULATION(HWK 3L SYS)

(An insulation sheet is under the G4 power supply board)

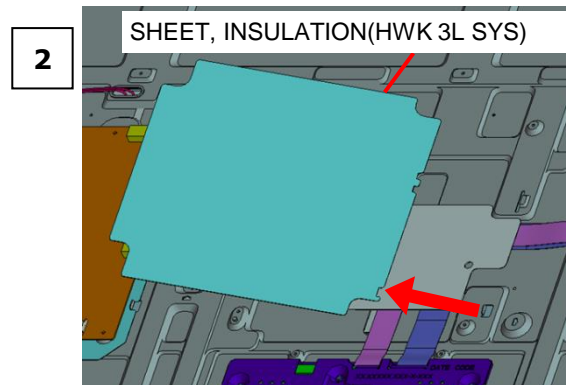
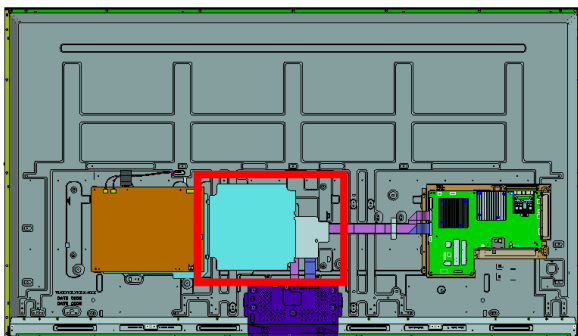

Notes on assembling the Insulation sheet (HWK 3L SYS)

Adhesive tape area

Caution

When handling,
 • Be sure not to touch adhesive tape area.
 After installing,
 • Be sure to push all of adhesive tape area to avoid peel off of "Sheet, Insulation".

To avoid coming off from panel

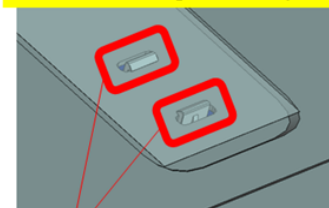

Don't push here.
 There is support pin.

Support pin

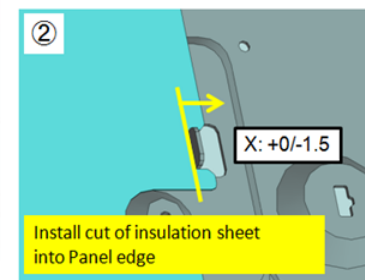
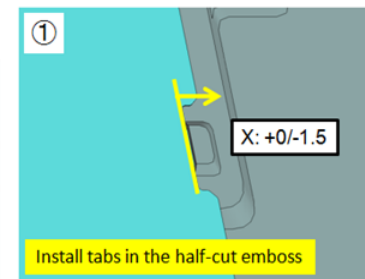
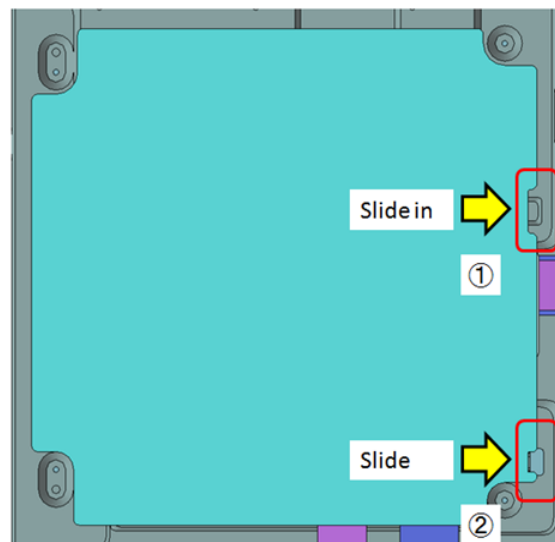

1-3. XBR-75X850C/855C

1-3-23. GL2-STATIC CONVERTER(TV)

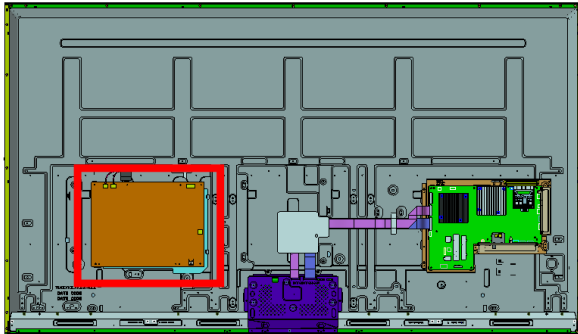

1

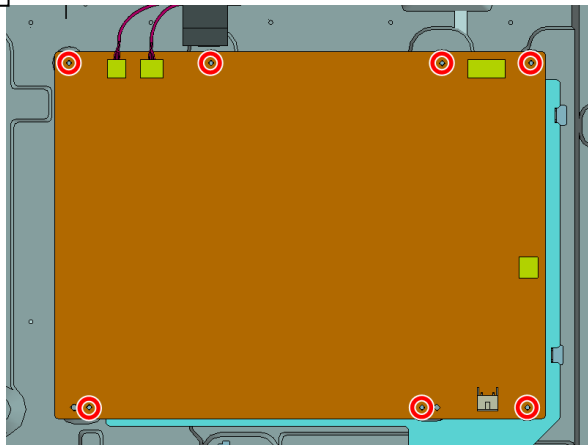

7 screws (SCREW, +PSW M3X6 W12) P/N: 4-256-393-11

2

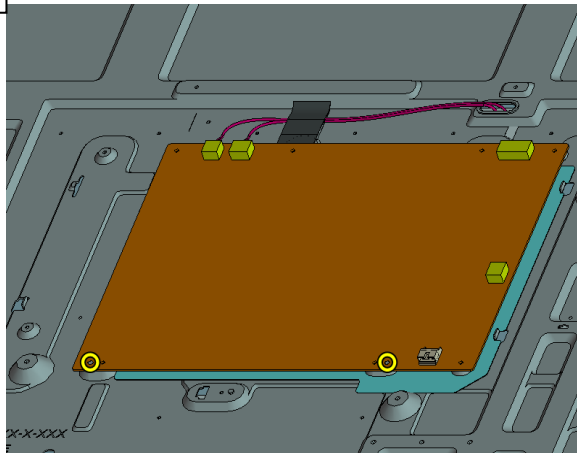

3

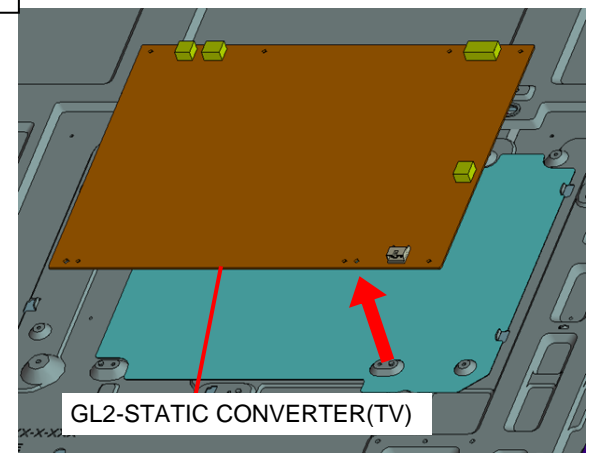

1-3. XBR-75X850C/855C

1-3-24. SHEET, INSULATION(HWK 3L)

(An insulation sheet is under the GL2 power supply board)

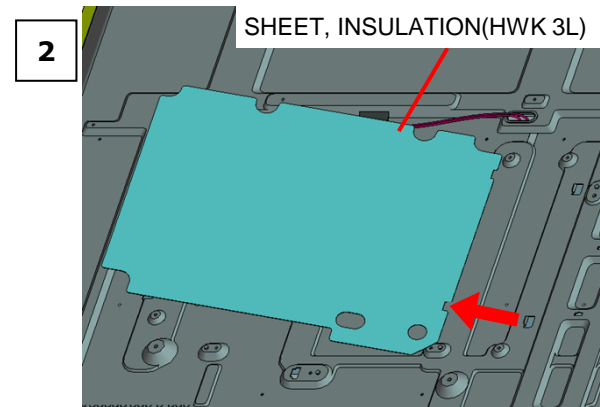
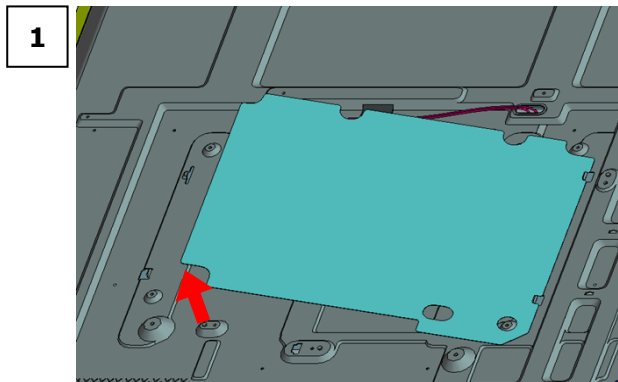
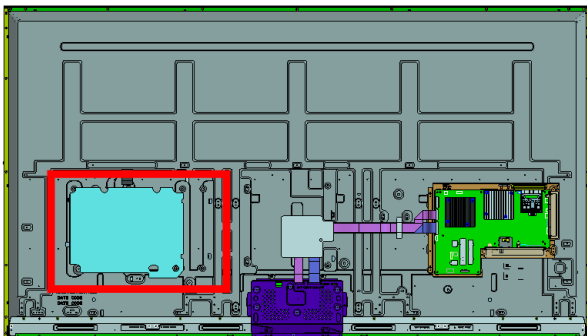

Notes on assembling the Insulation sheet (HWK 3L)

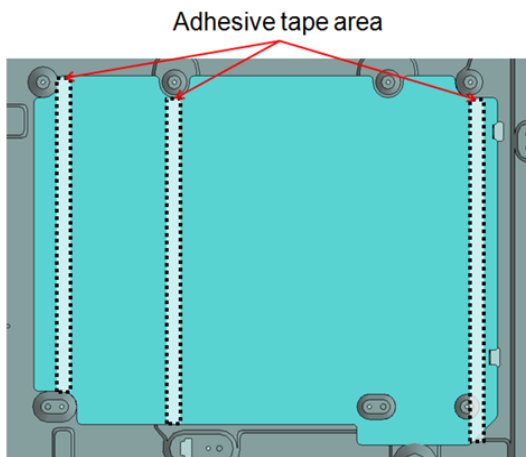

Caution

- When handling,
 - Be sure not to touch adhesive tape area.
- After installing,
 - Be sure to push all of adhesive tape area to avoid peel off of "Sheet, Insulation".

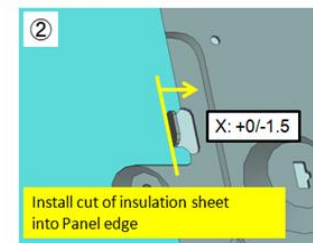
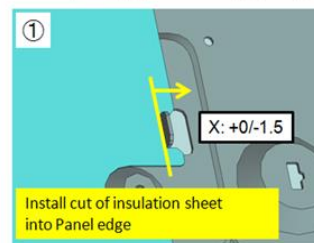
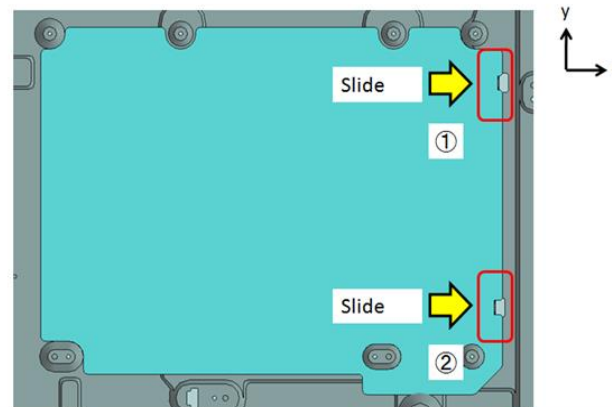

1-3. XBR-75X850C/855C

1-3-25. TAPE, FFC (HWK 3L)

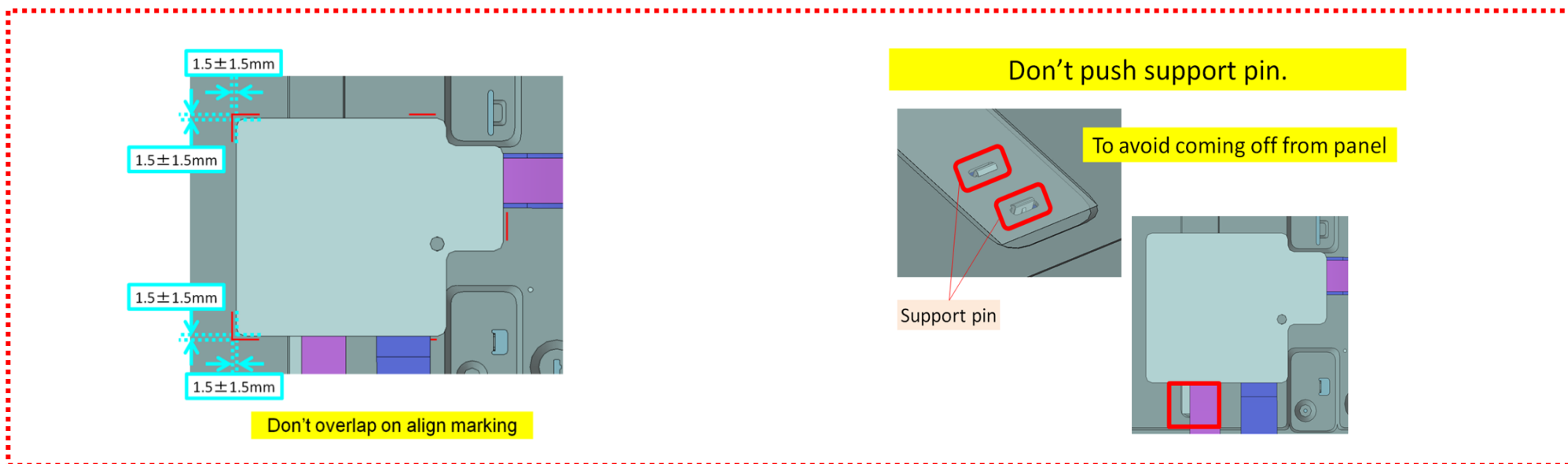
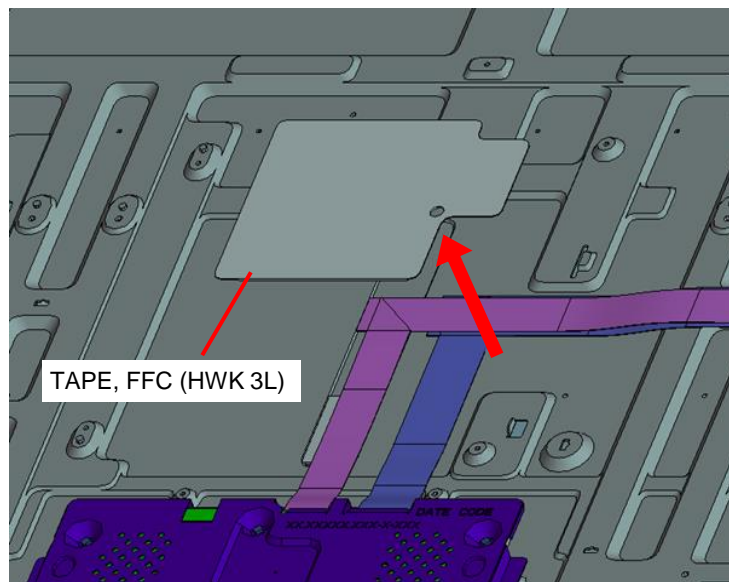
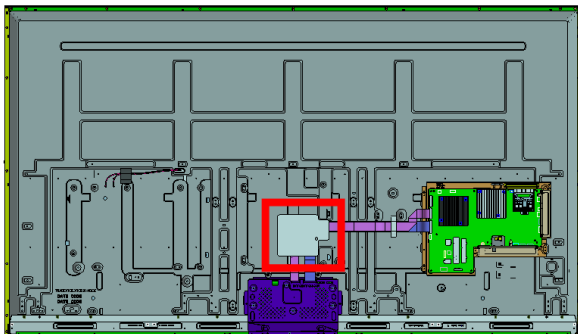

1.5±1.5mm

1.5±1.5mm

1.5±1.5mm

1.5±1.5mm

Don't overlap on align marking

Don't push support pin.

To avoid coming off from panel

Support pin

1-3. XBR-75X850C/855C

1-3-26. FLEXIBLE FLAT CABLE 41P AND FLEXIBLE FLAT CABLE 51P

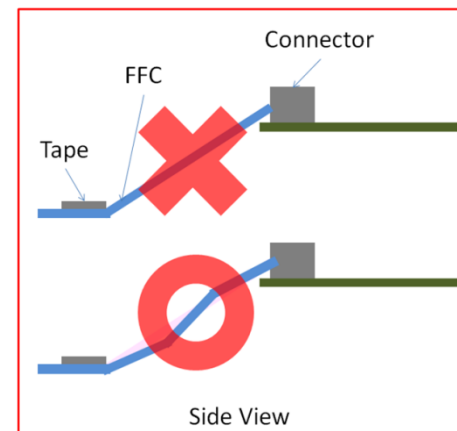
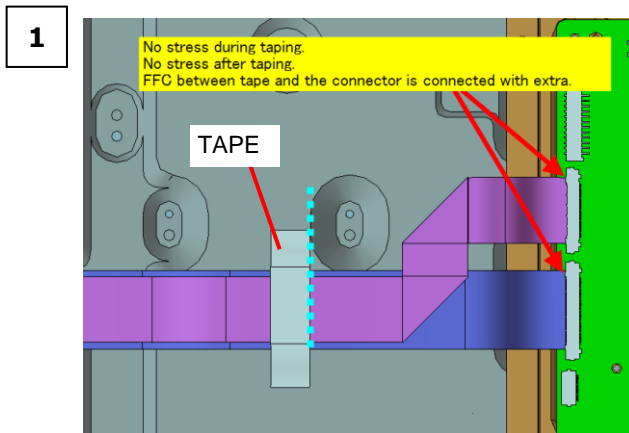
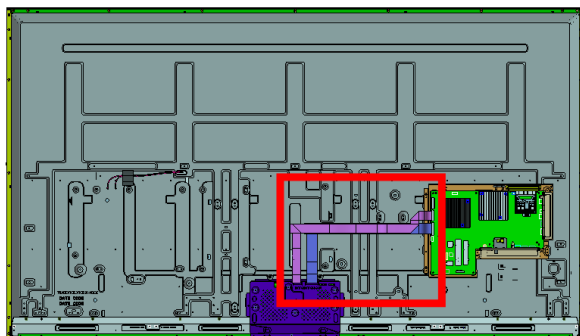

2 FLEXIBLE FLAT CABLE 41P
P/N: 1-848-890-11

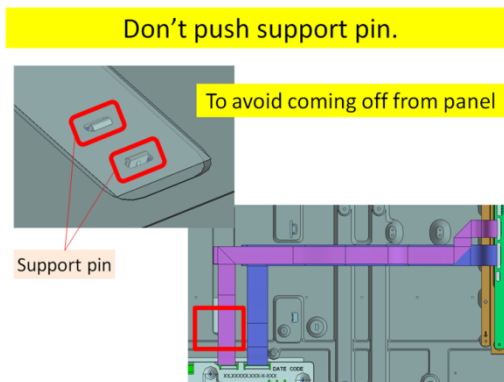

3 FLEXIBLE FLAT CABLE 51P
P/N: 1-848-891-11

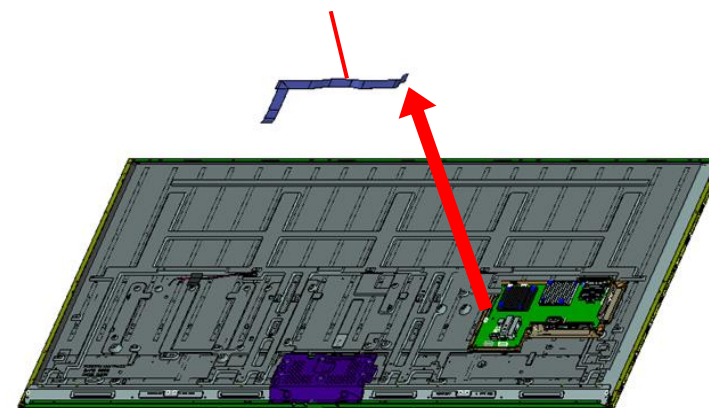

1-3. XBR-75X850C/855C

1-3-27. BRACKET, UNDER FL (MOLD)

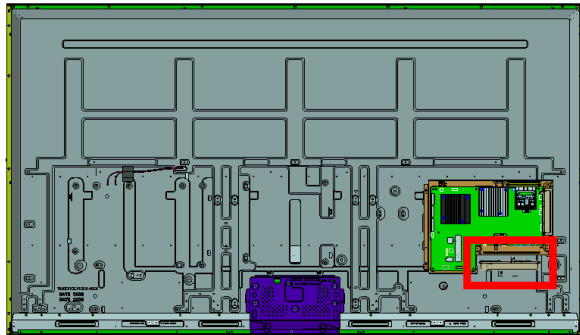

1

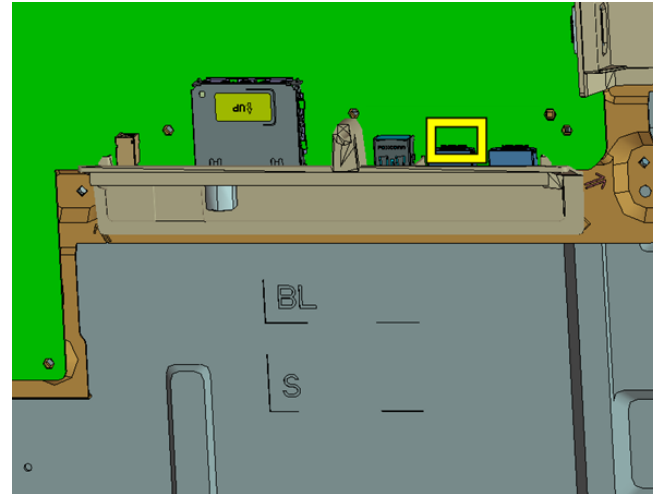

2

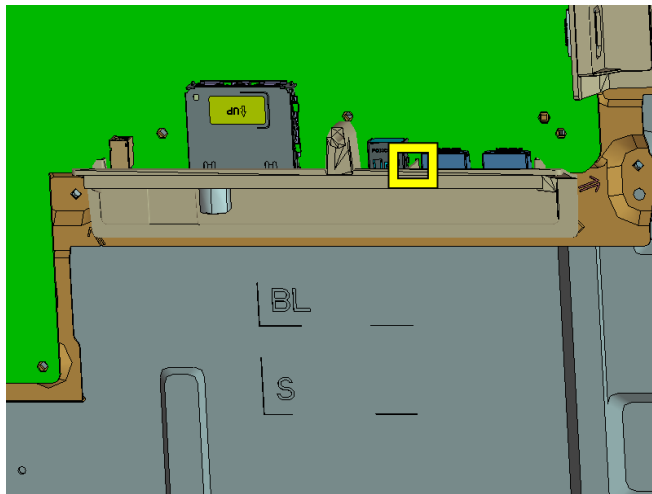

3

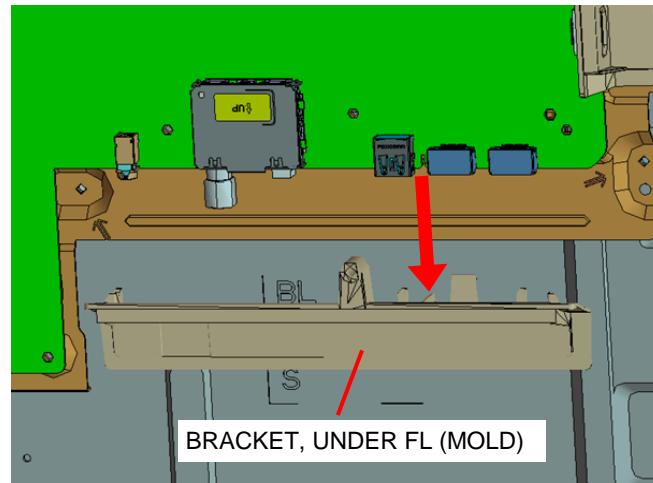

1-3. XBR-75X850C/855C

1-3-28. BRACKET, SIDE FL (MOLD)

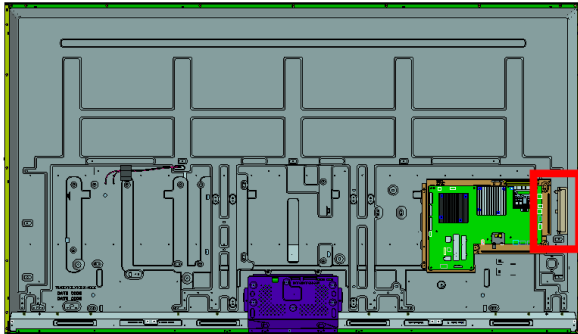

1

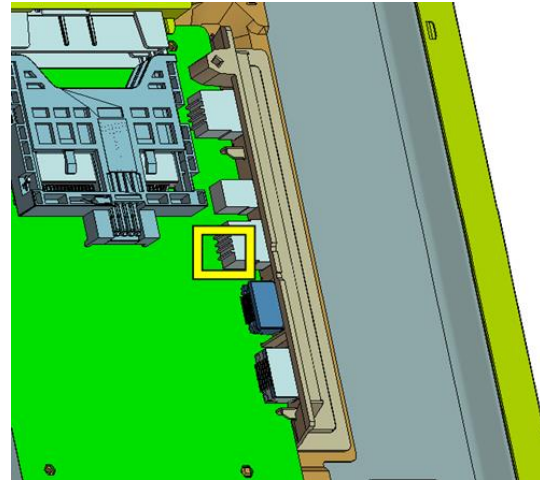

2

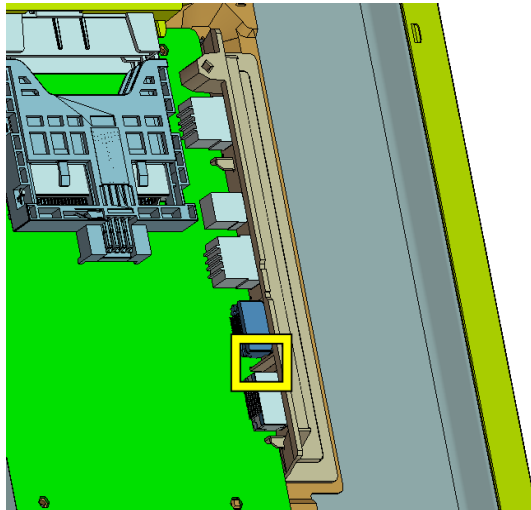

3

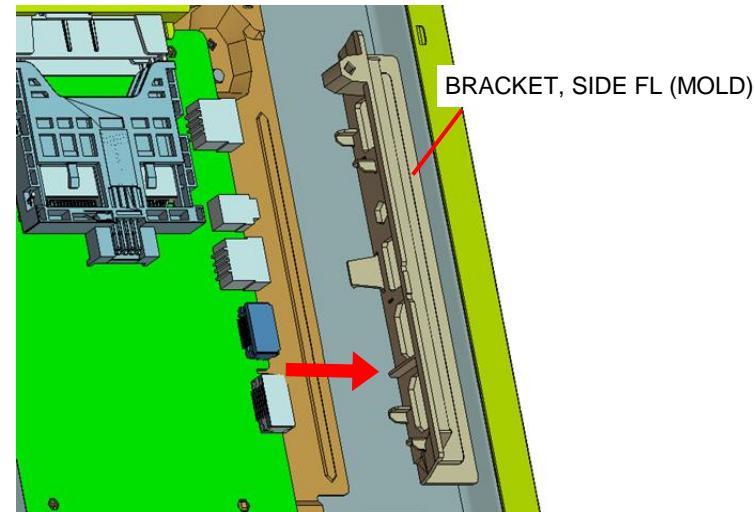

1-3. XBR-75X850C/855C

1-3-29. PLATE, MAIN(HWK) ASSY

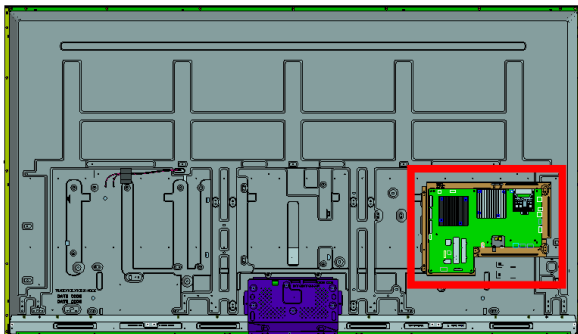

1

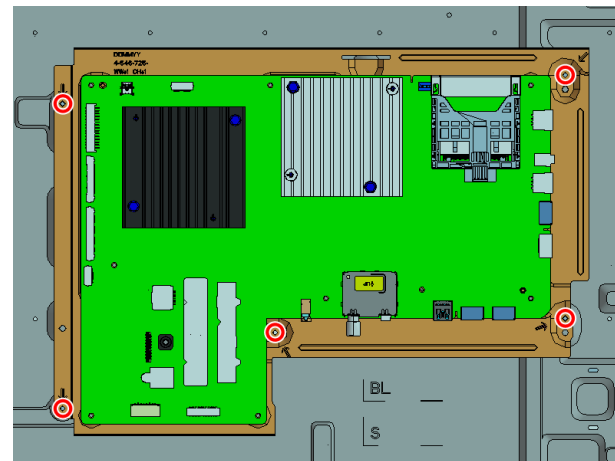

5 screws (SCREW, +PSW M3X8) P/N: 2-580-593-01

2

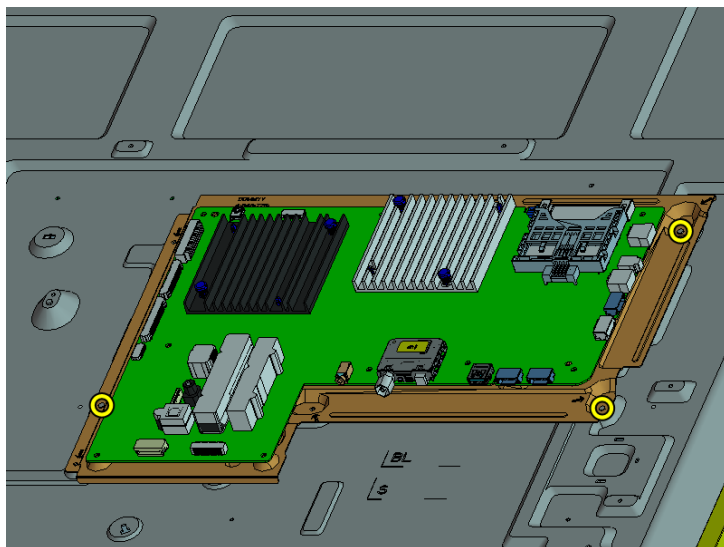

3

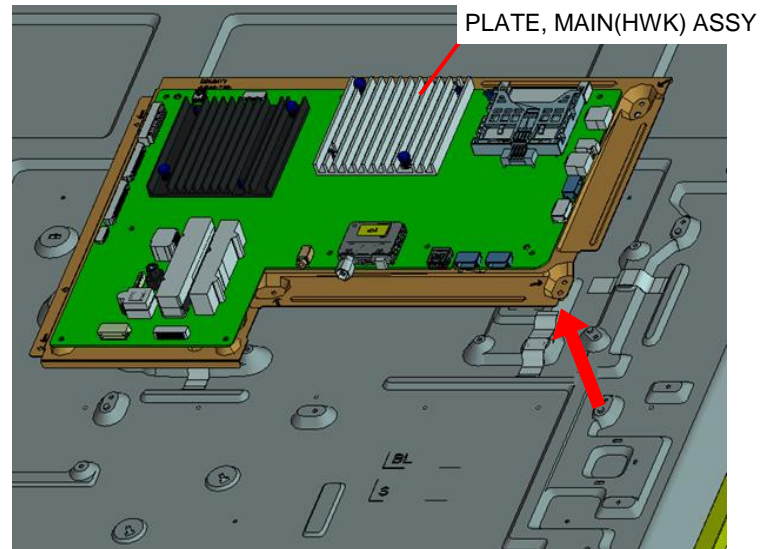

1-3. XBR-75X850C/855C

1-3-30. BMFL ASSY

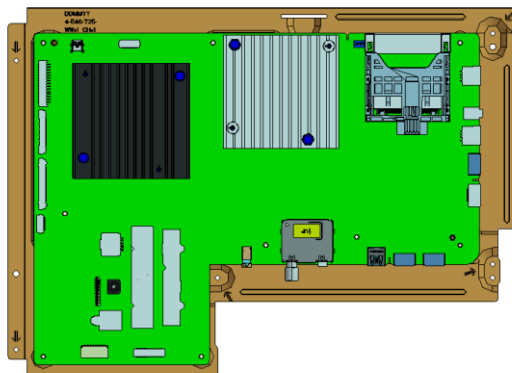

1

<Sequence Information>

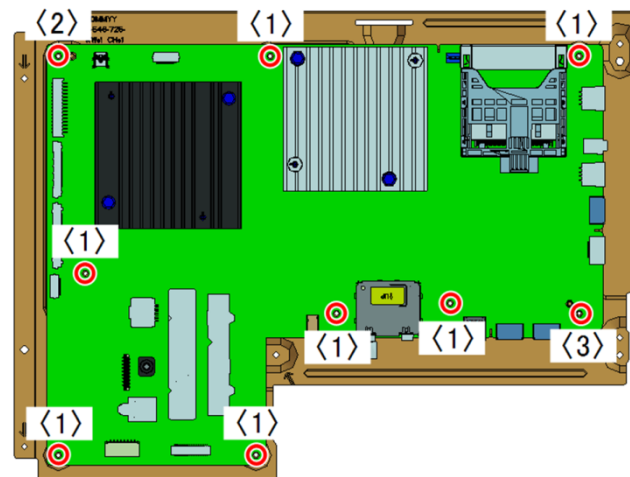

9 screws (SCREW (+PSW)(M3X6)) P/N: 2-990-421-41

2

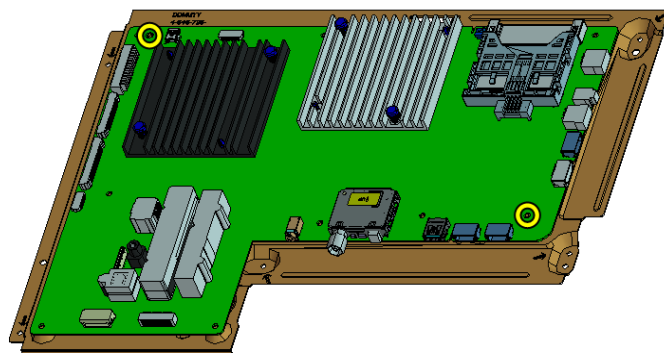

3

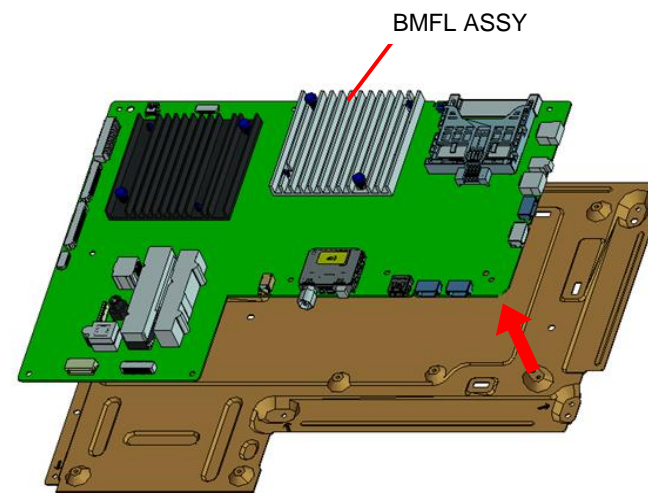

1-3. XBR-75X850C/855C

1-3-31. GASKET (BMF)

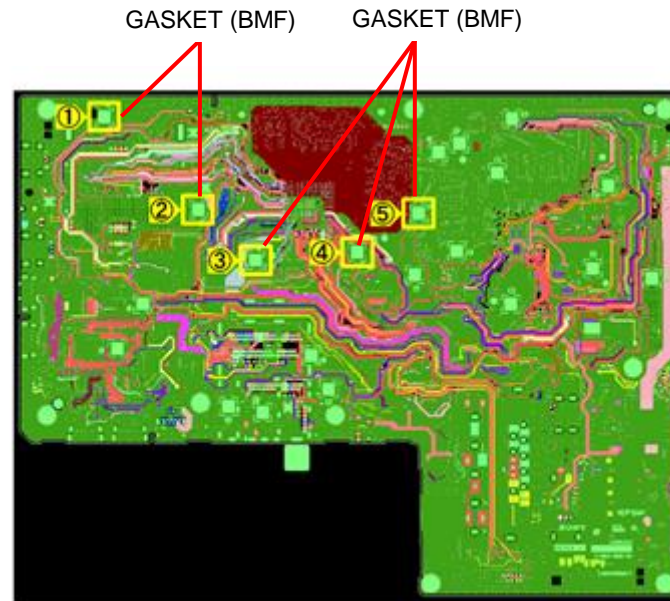
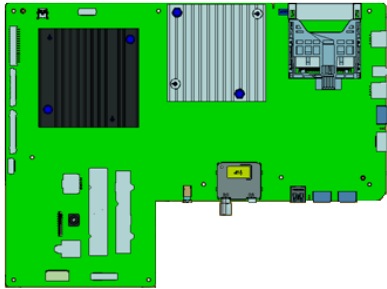

NOTE:

When you replace a BMFL board, it is necessary to stick five new GASKET on a new BMFL board.

GASKET (BMF): 4-566-117-01

Stick GASKET inside the guide line.

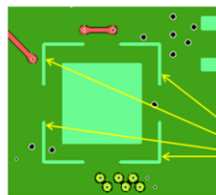

Guide line

*No indication of direction

Caution:

1. Please aim at the center of square land.
2. Assy the gaskets just before B board panel installation.

To stick the GASKET firmly,
Press the gasket until compression completely.
(0.5-1.0kgf)



1-3. XBR-75X850C/855C

1-3-32. SHEET, THERMAL(BM) AND PLATE, MAIN(HWK)

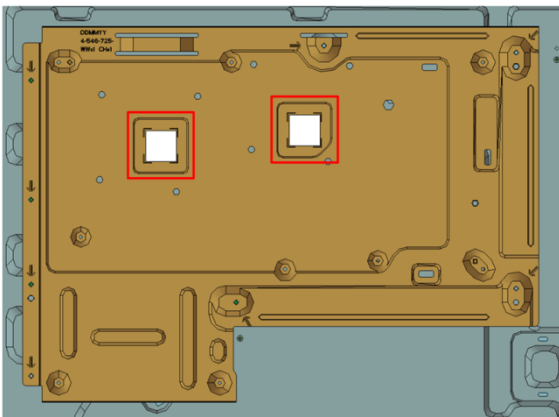

1

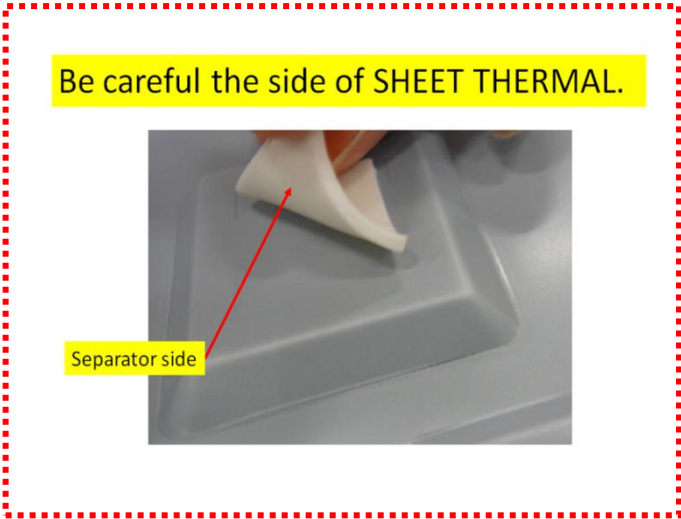
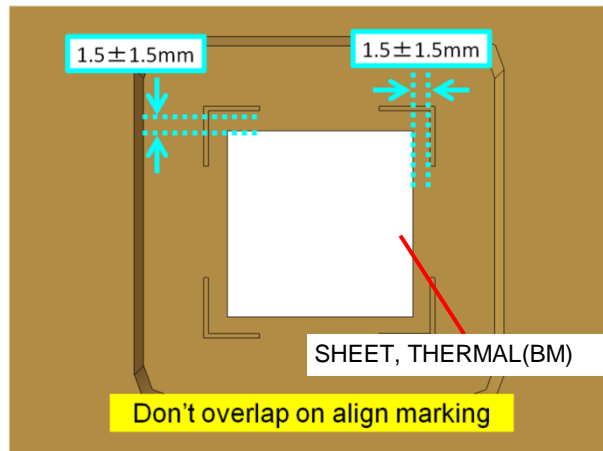

2

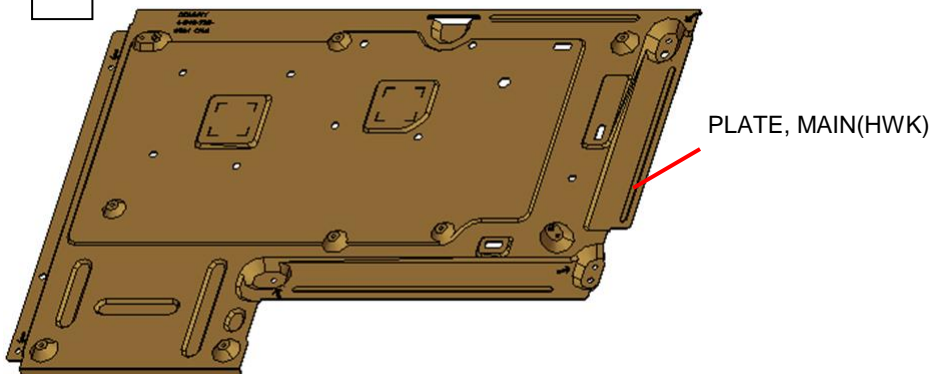

1-3. XBR-75X850C/855C

1-3-33. CUSHION, CORNER(EGL) AND TAPE

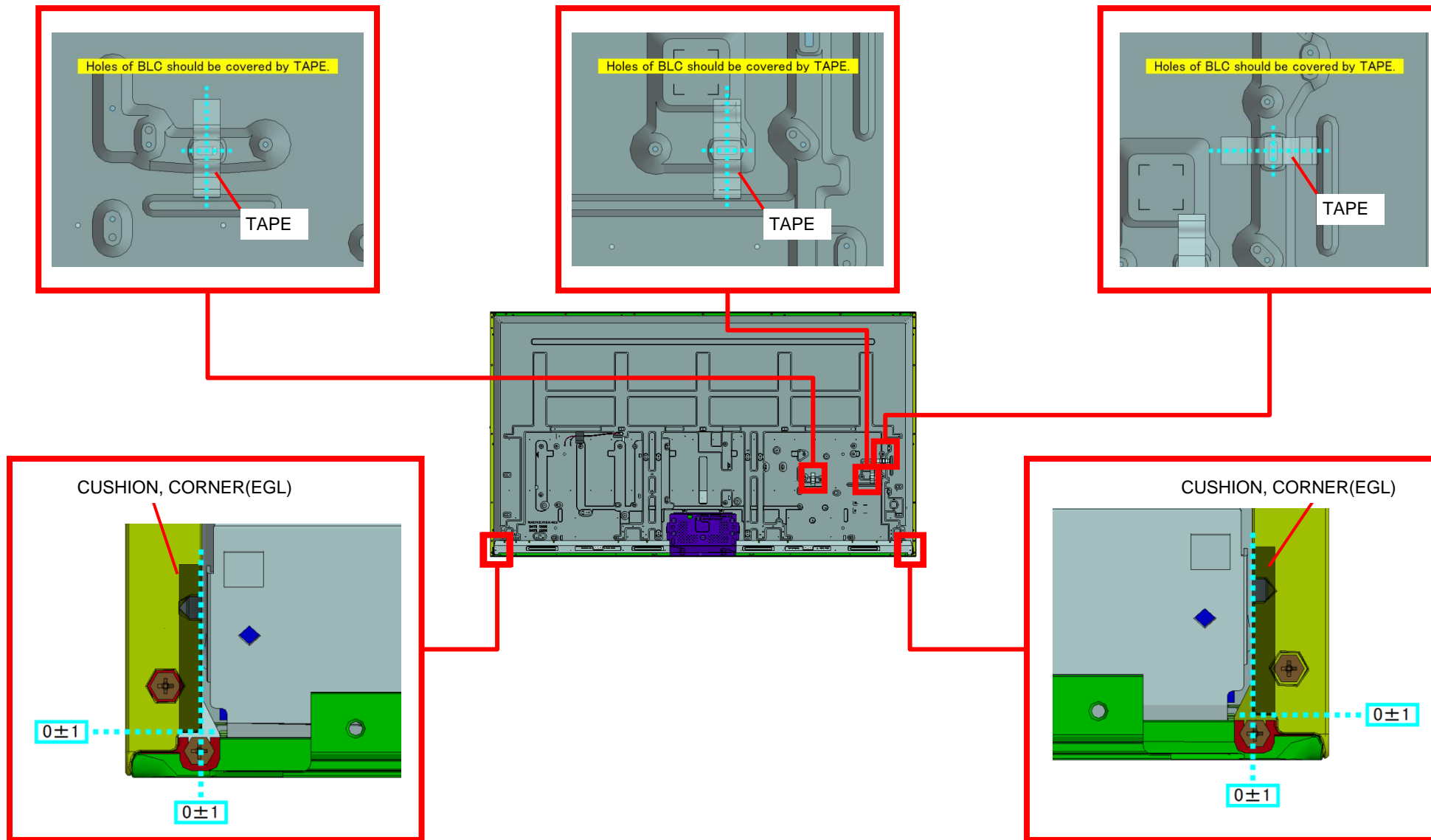

1-3. XBR-75X850C/855C

1-3-34. LCD PANEL

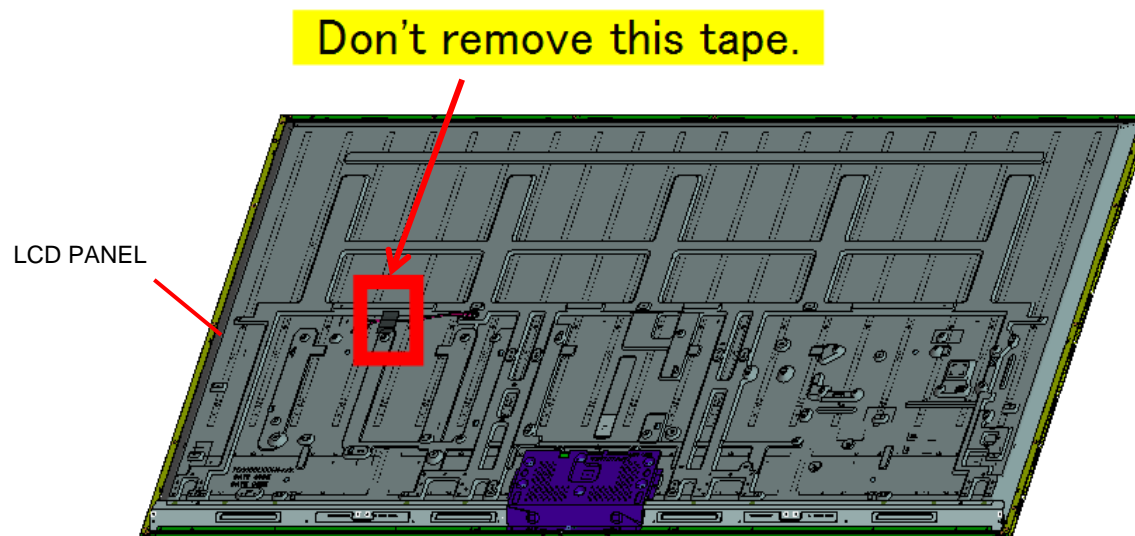

1-4. SMART CORE (M,L)

1-4-1. WLAN / BT MODULE(11AC) ASSY

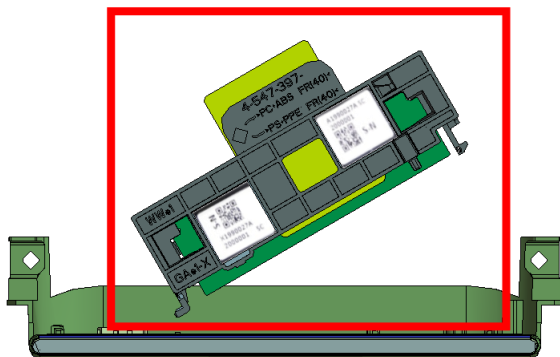

1

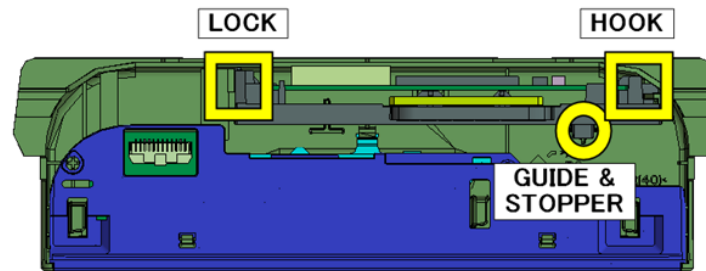

2

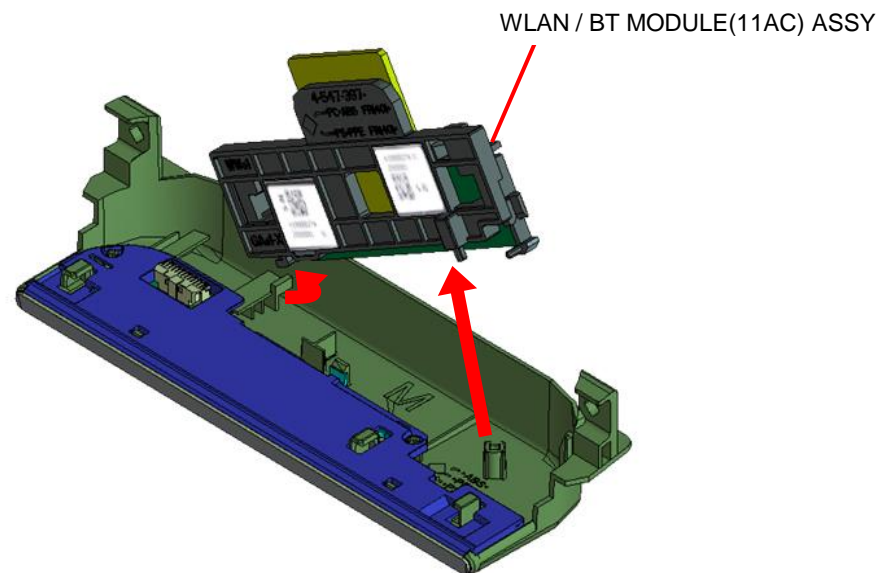

1-4. SMART CORE (M,L)

1-4-2. WLAN / BT MODULE(11AC)

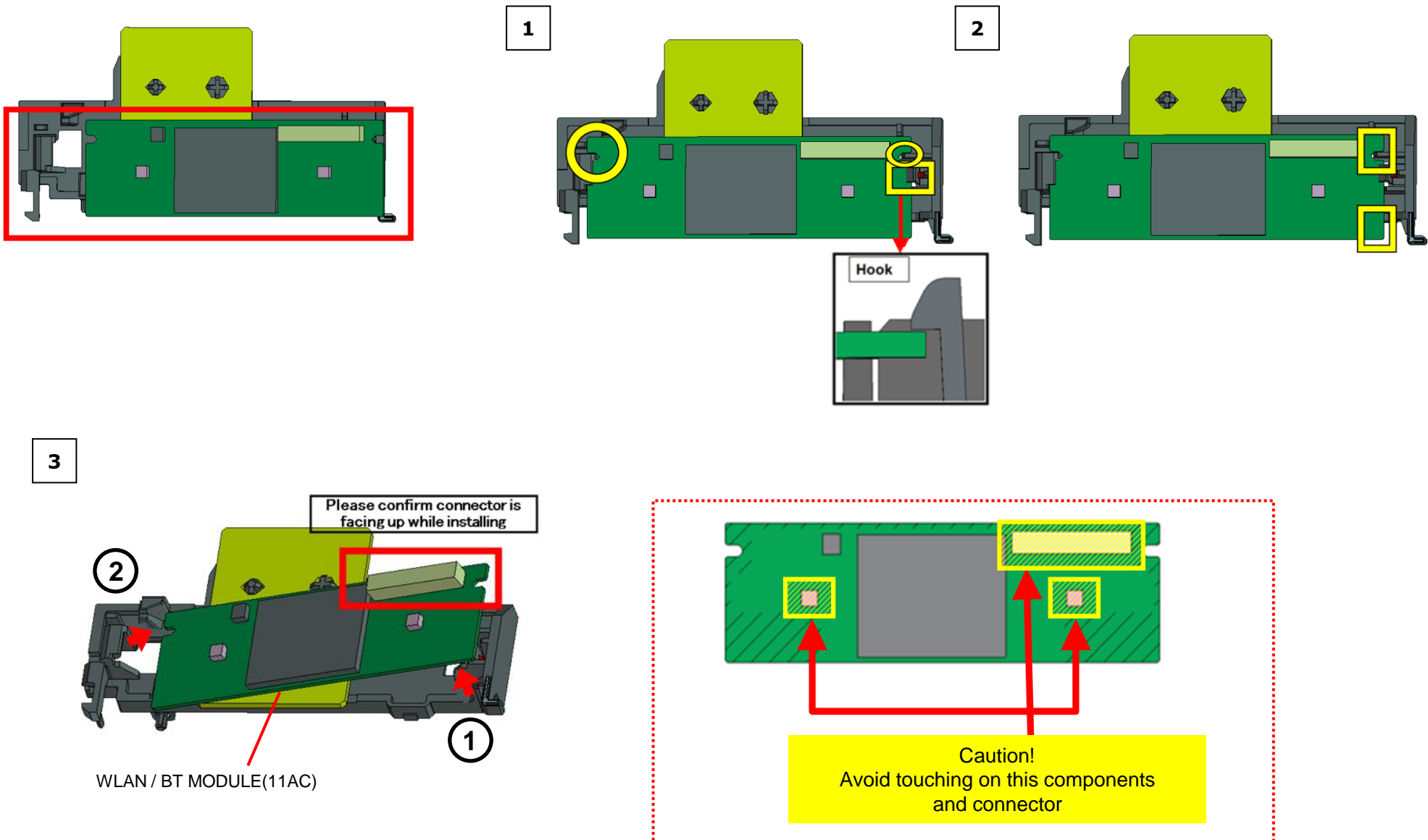

1-4. SMART CORE (M,L)

1-4-3. SHEET, THERMAL (SC)

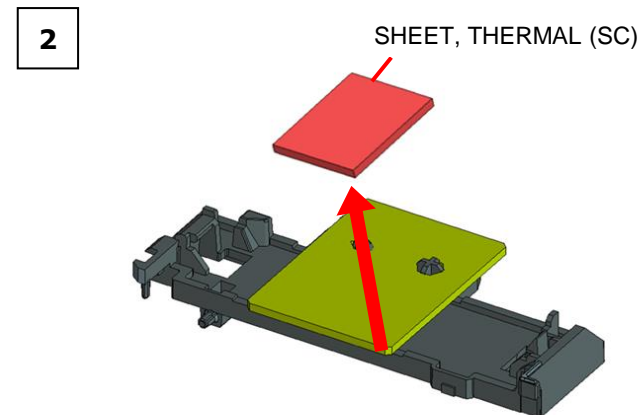
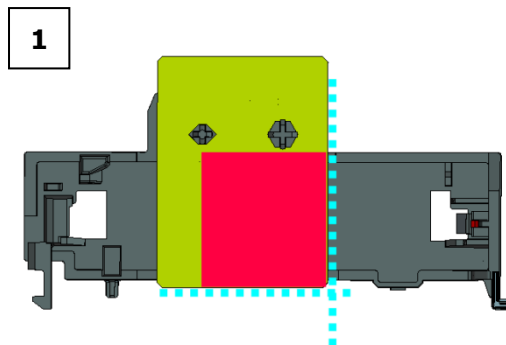
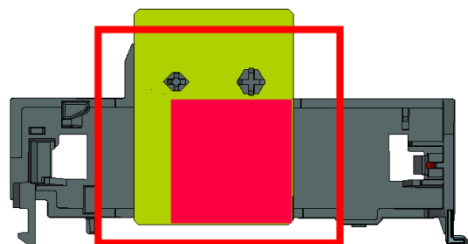

1-4-4. HEAT SINK L (SC)

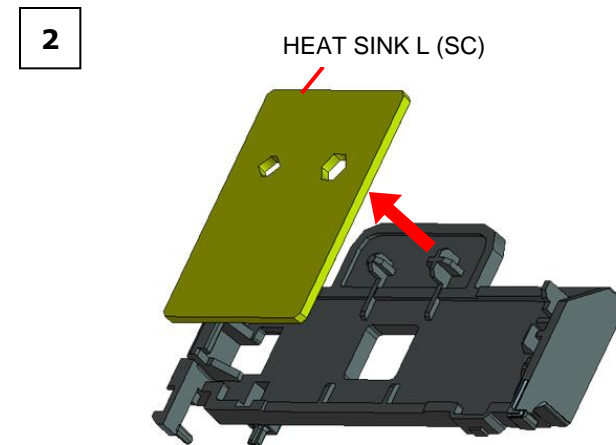
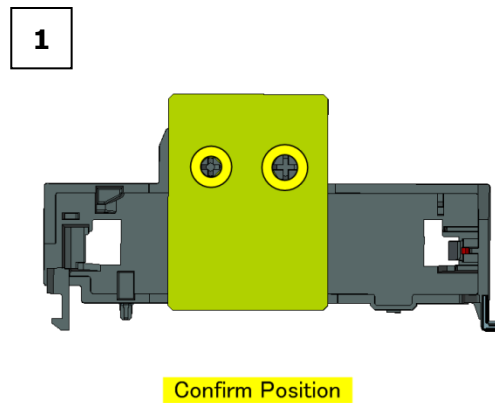
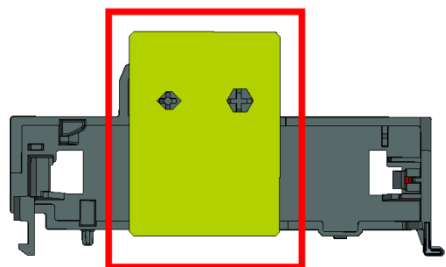

1-4. SMART CORE (M,L)

1-4-5. COVER, TOP

1

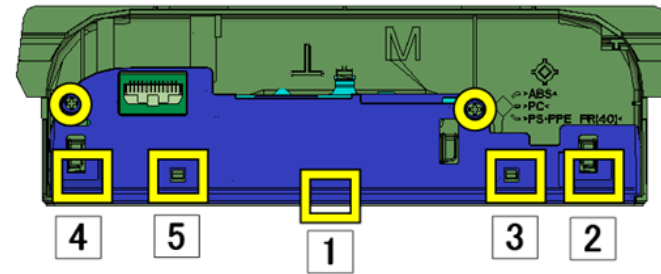
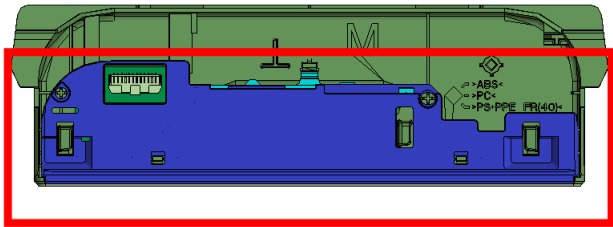

2

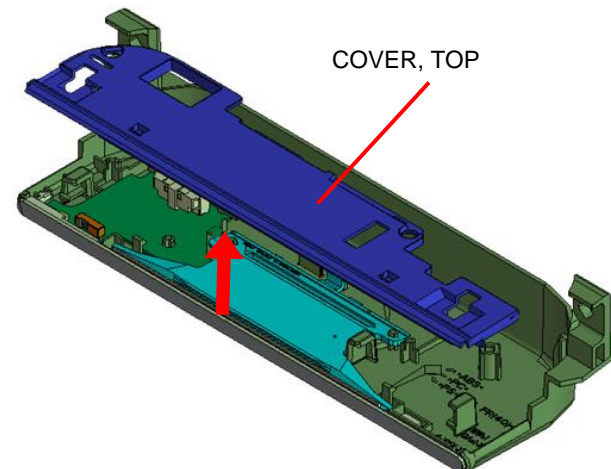

1-4. SMART CORE (M,L)

1-4-6. PANEL, ORNAMENT

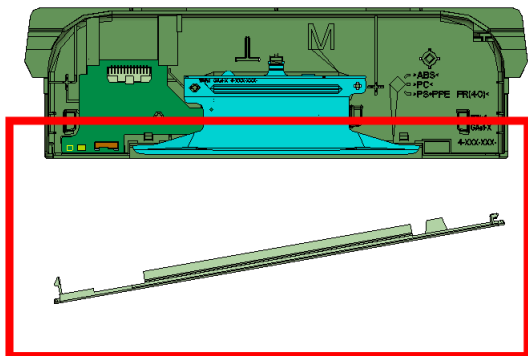

2

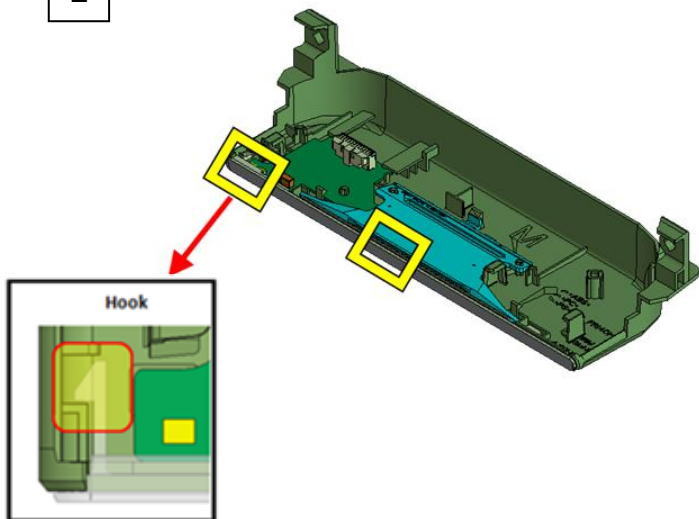

1

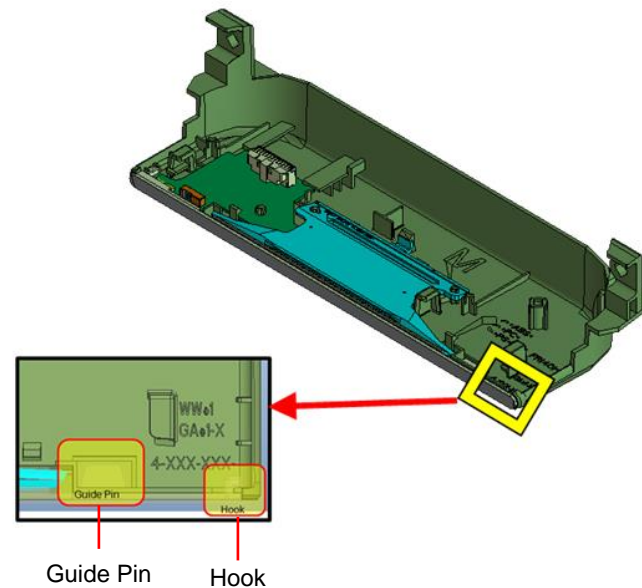

3

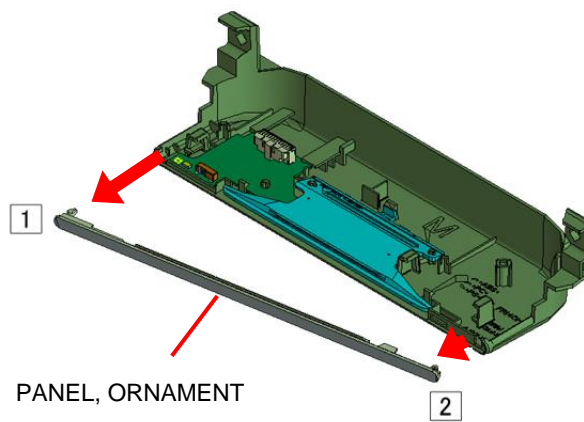

1-4. SMART CORE (M,L)

1-4-7. LIGHT, GUIDE

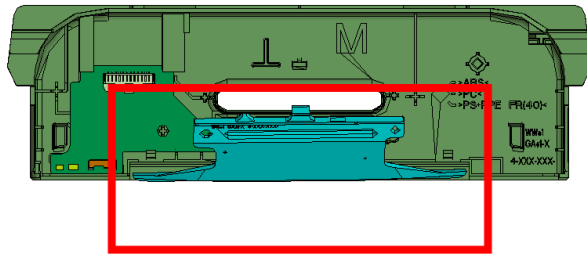

1

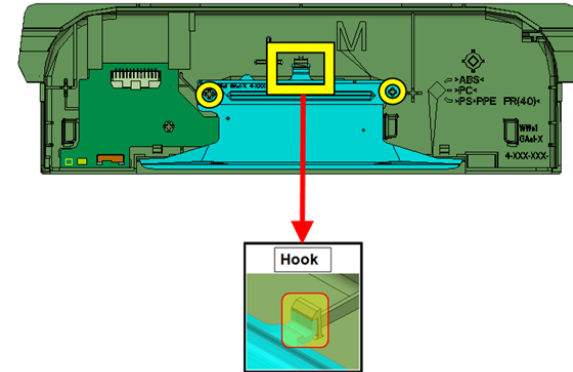

2

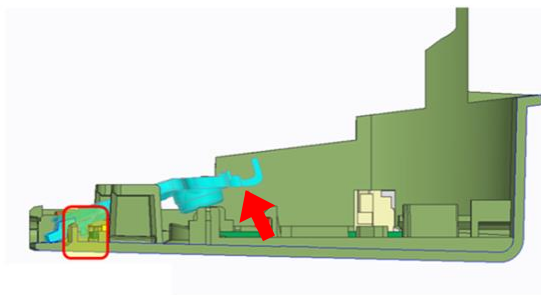

3

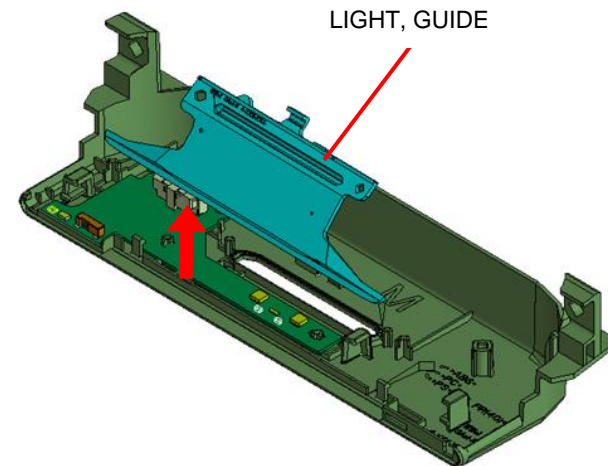

1-4. SMART CORE (M,L)

1-4-8. HSC3_S_M MOUNT

1

2

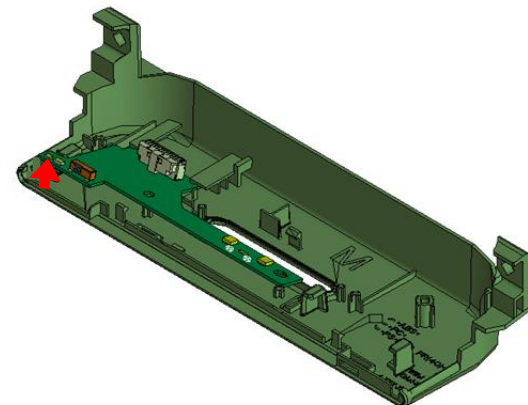
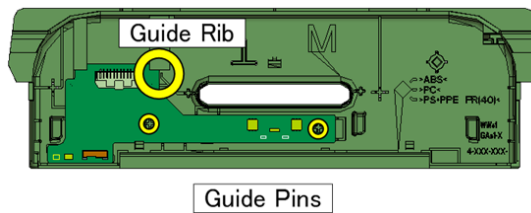
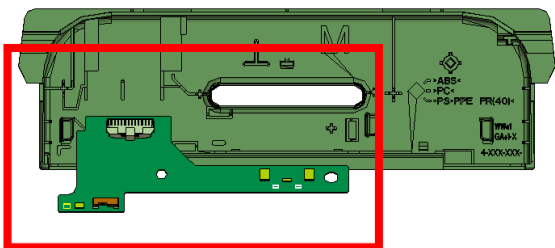

3

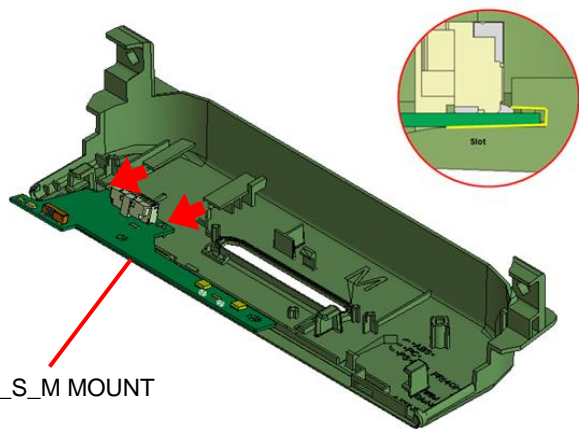

HSC3_S_M MOUNT

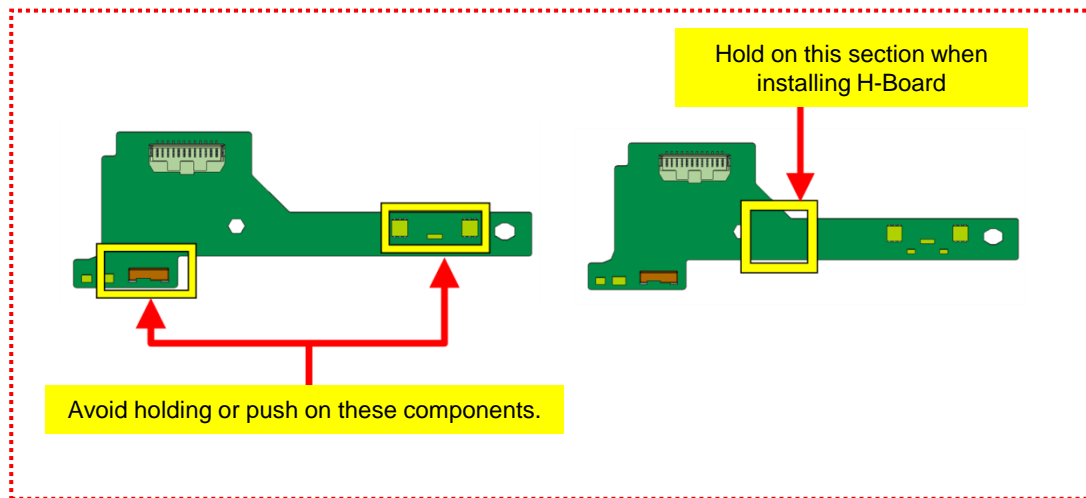

1-4. SMART CORE (M,L)

1-4-9. CASE, BOTTOM (M)

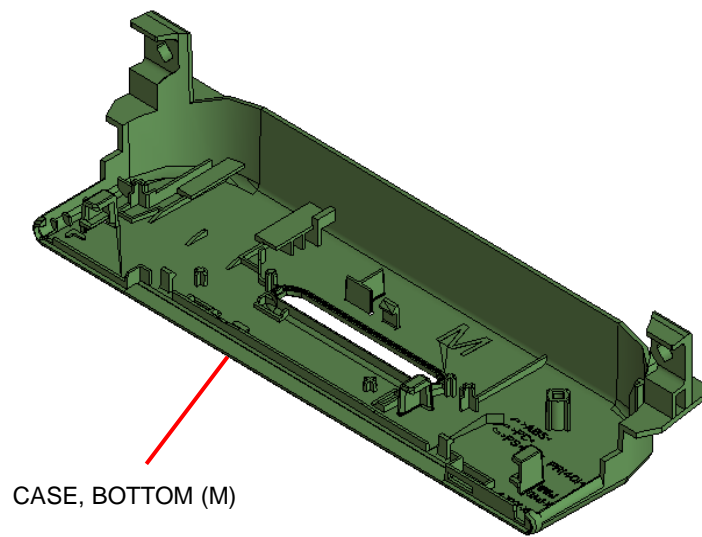

1-5. SMART CORE (L,C)

1-5-1. WLAN / BT MODULE(11AC) ASSY

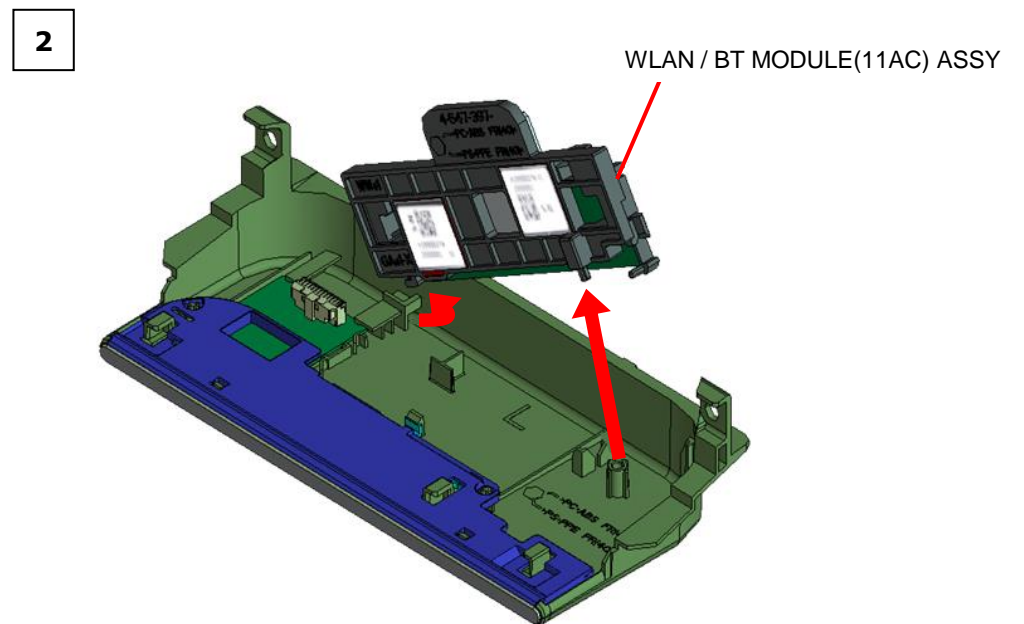
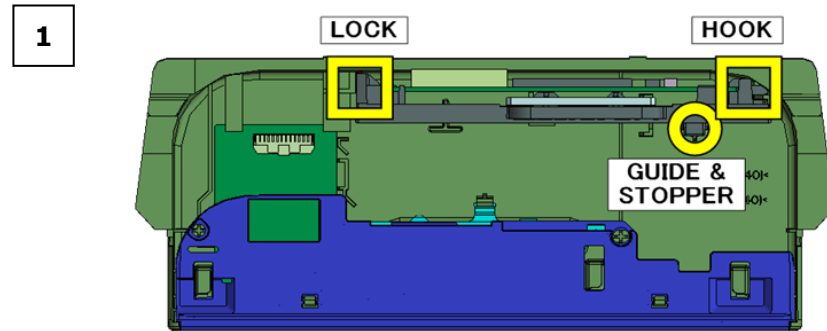
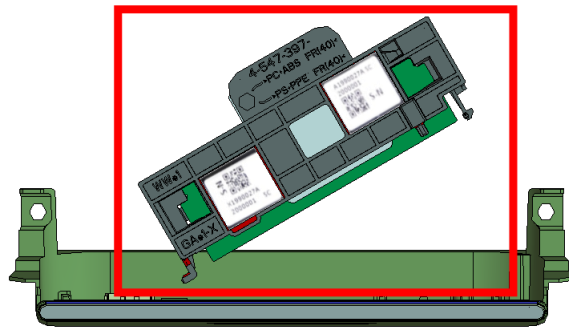

1-5. SMART CORE (L,C)

1-5-2. WLAN / BT MODULE(11AC)

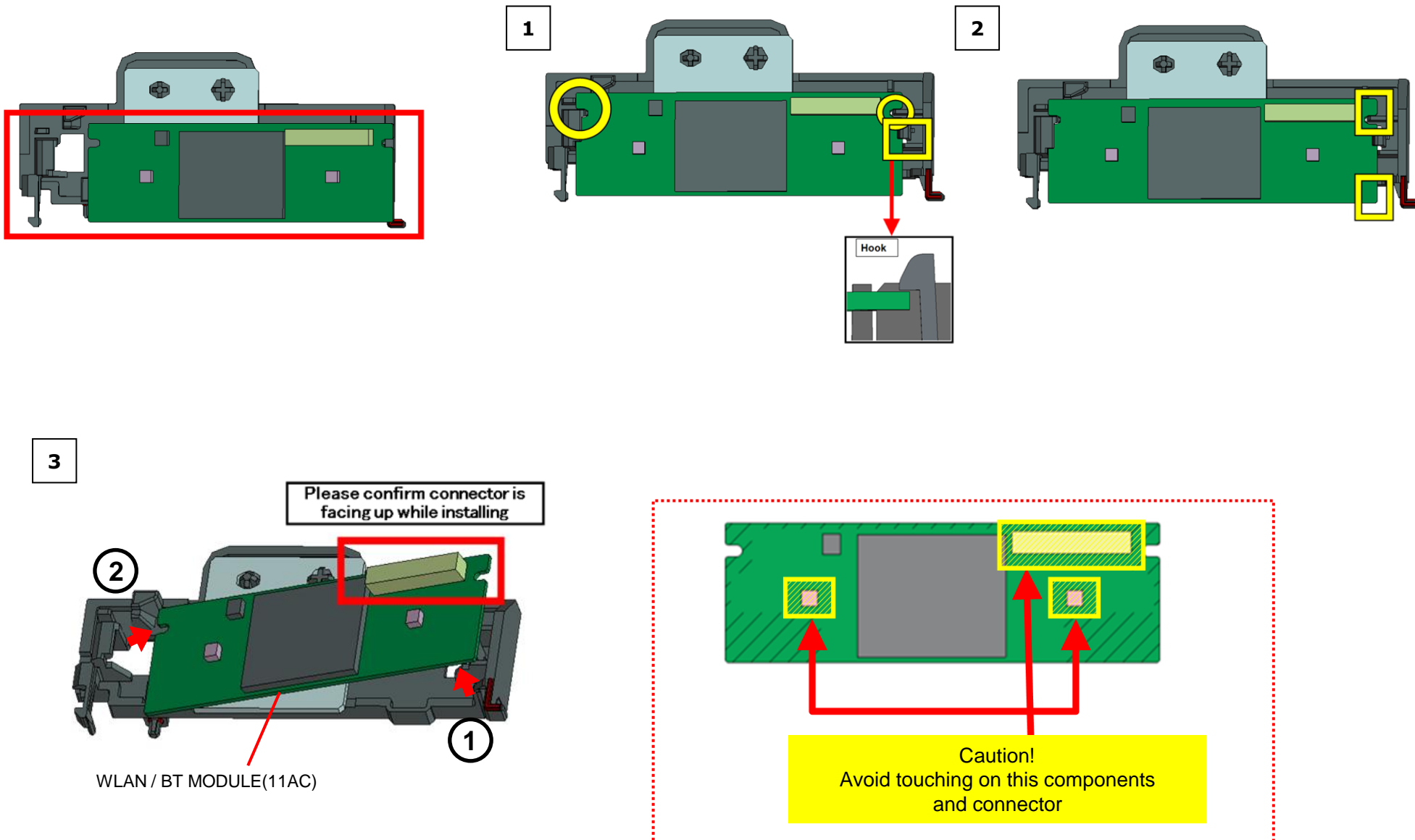

1-5. SMART CORE (L,C)

1-5-3. SHEET, THERMAL (SC)

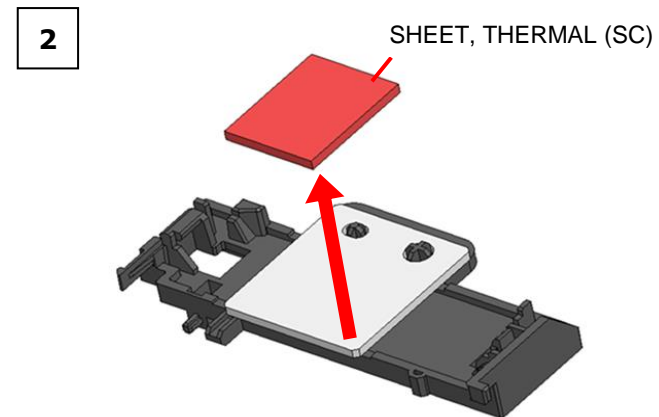
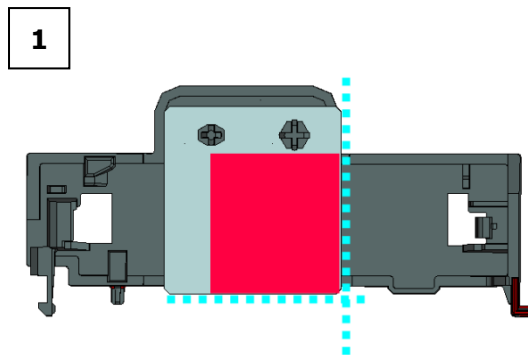
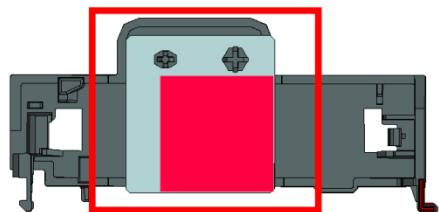

1-5-4. HEAT SINK (SC)

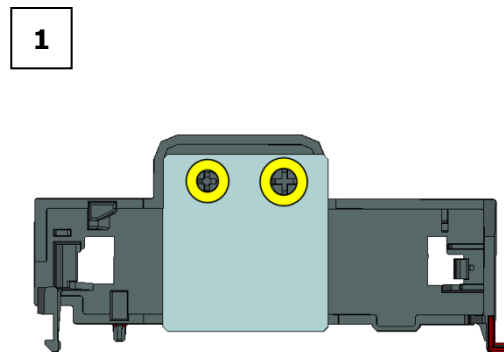
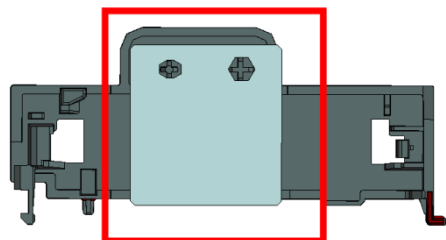

Confirm Position

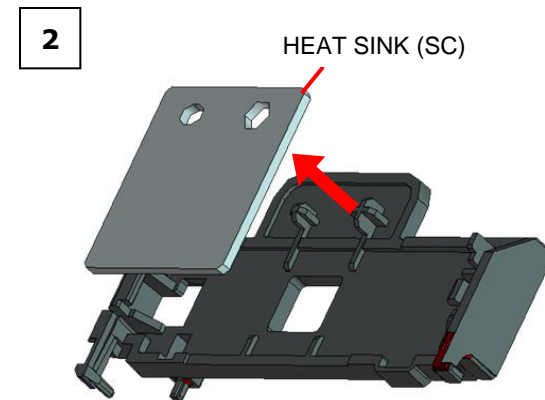

1-5. SMART CORE (L,C)

1-5-5. COVER, TOP

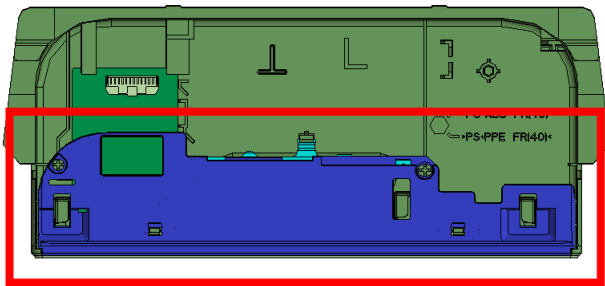

1

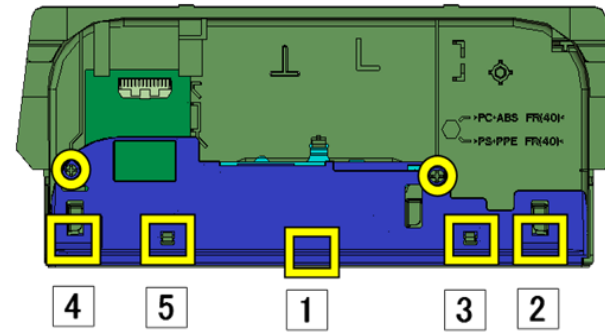

2

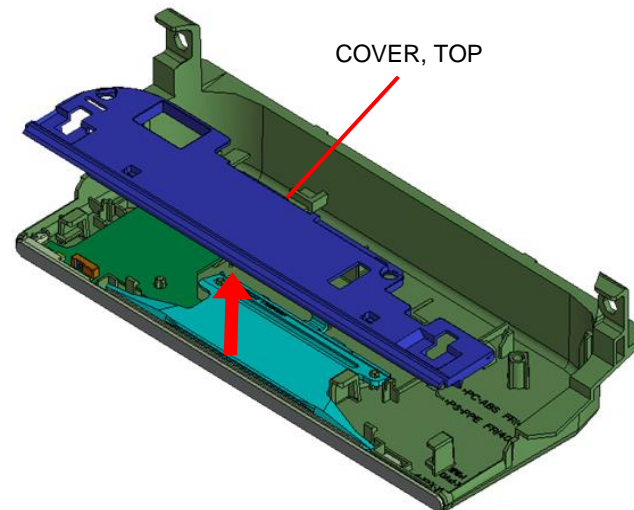

1-5. SMART CORE (L,C)

1-5-6. PANEL, ORNAMENT

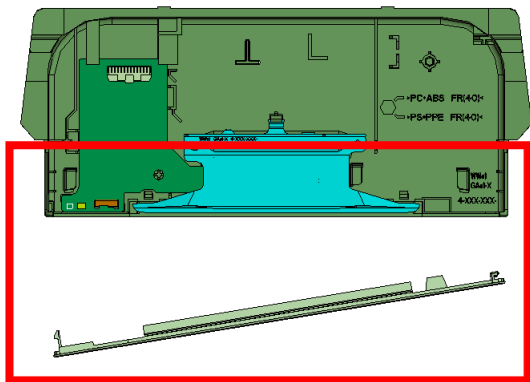

1

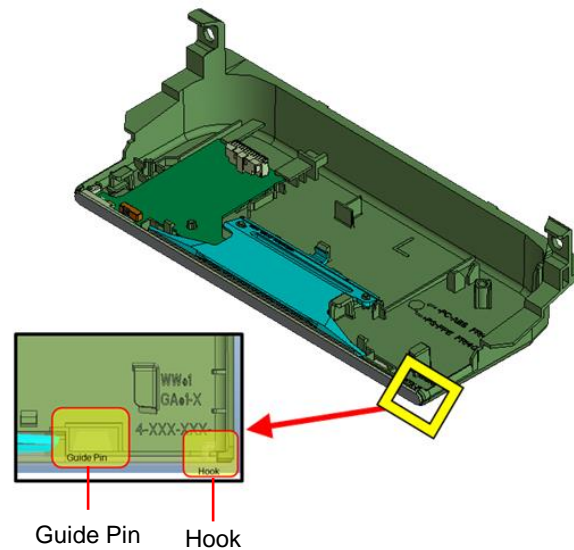

3

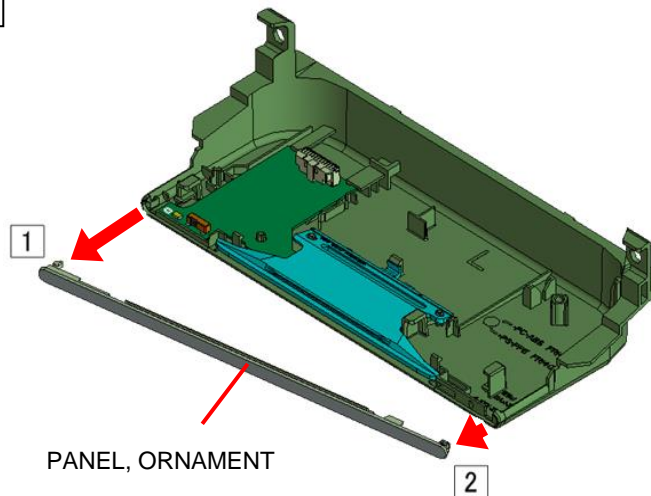

2

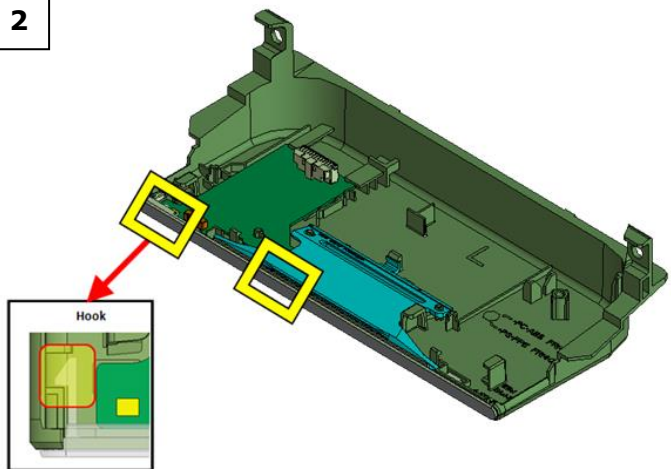

1-5. SMART CORE (L,C)

1-5-7. LIGHT, GUIDE

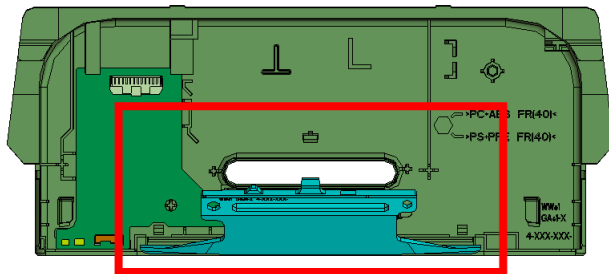

1

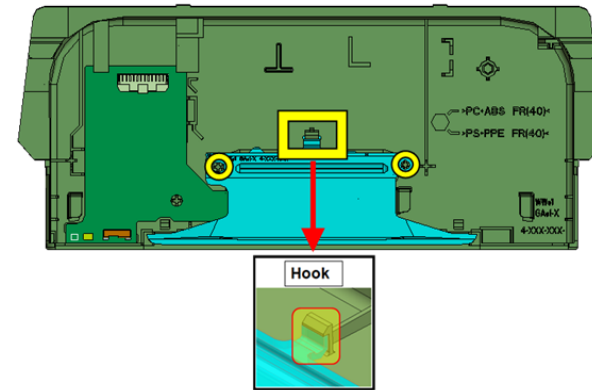

2

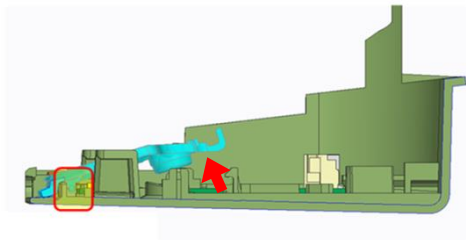

3

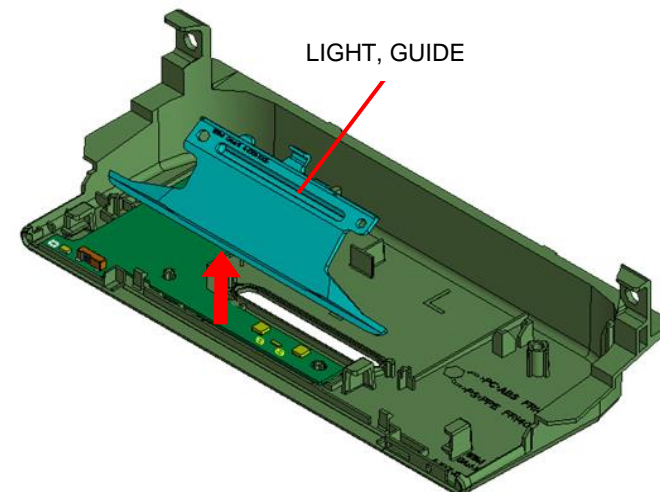

1-5. SMART CORE (L,C)

1-5-8. HSC3_L MOUNT

1

2

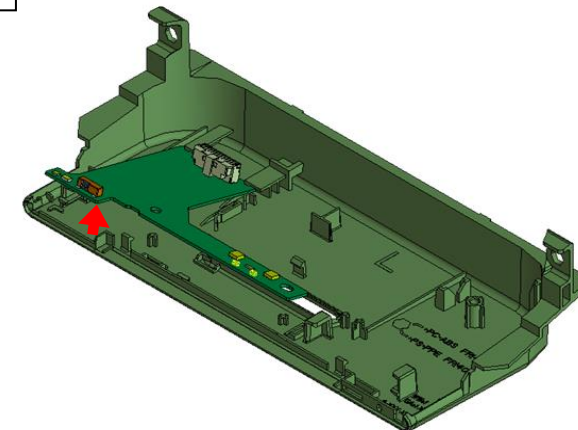
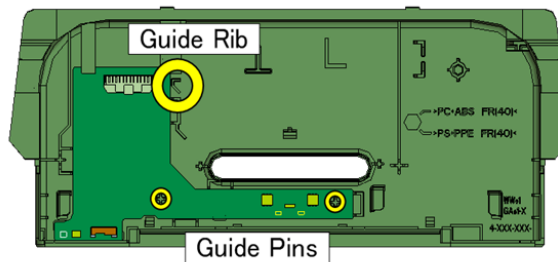
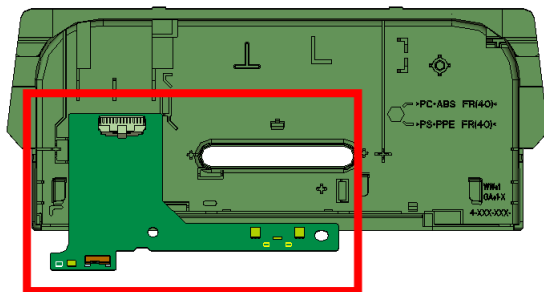

3

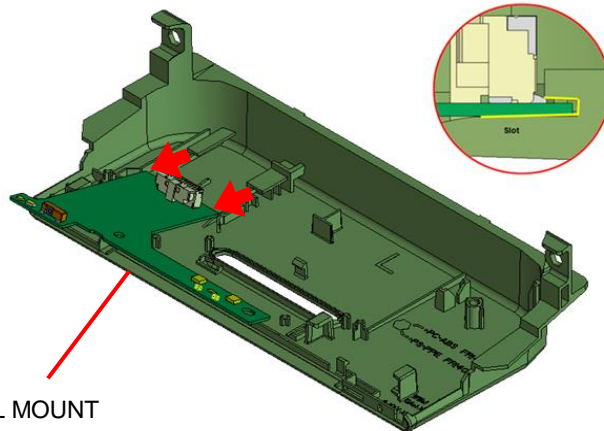

HSC3_L MOUNT

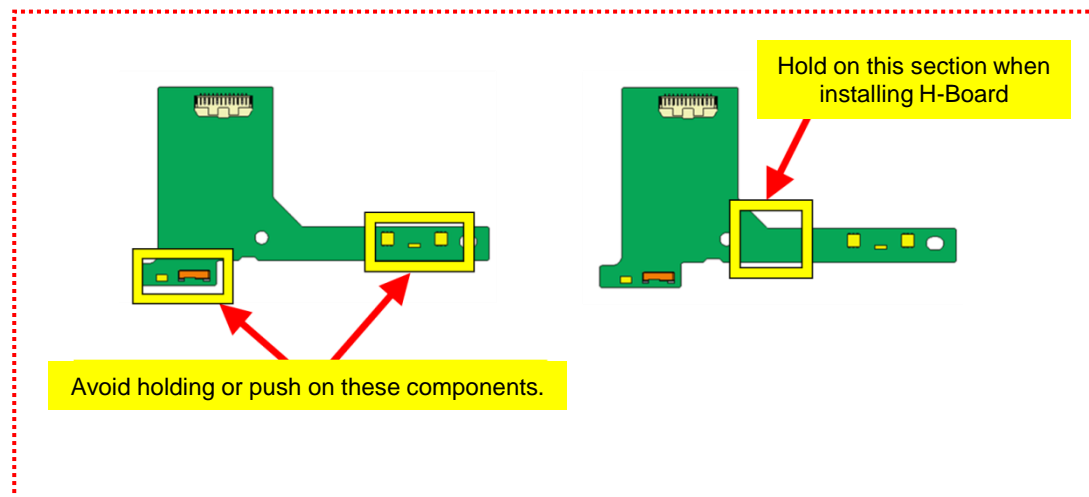

1-5. SMART CORE (L,C)

1-5-9. CASE, BOTTOM (L)

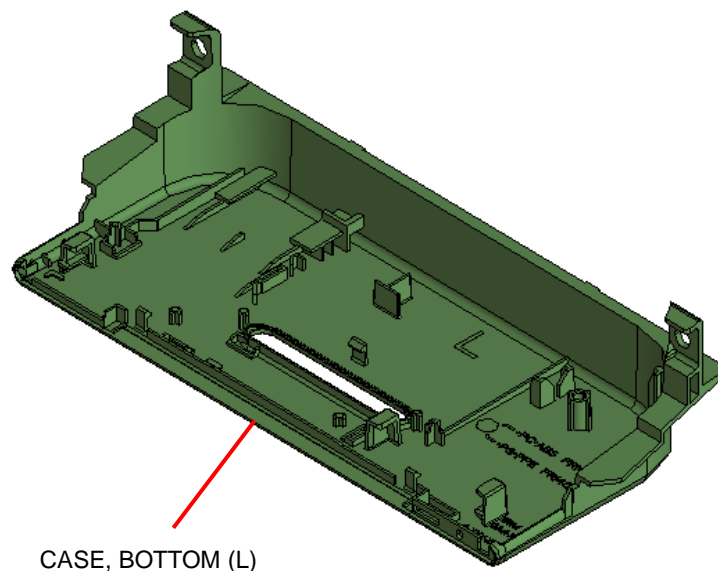

CASE, BOTTOM (L)

SEC 2. ADJUSTMENT

HOW TO ENTER THE SERVICE MODE

- 1) Turn on the main power switch to set in standby mode.
- 2) Press the buttons on the remote commander in the following sequence with each interval within 1 sec, then the service mode will be set.

DISPLAY → Channel 5 → Volume + → TV POWER

- 3) Service mode display.

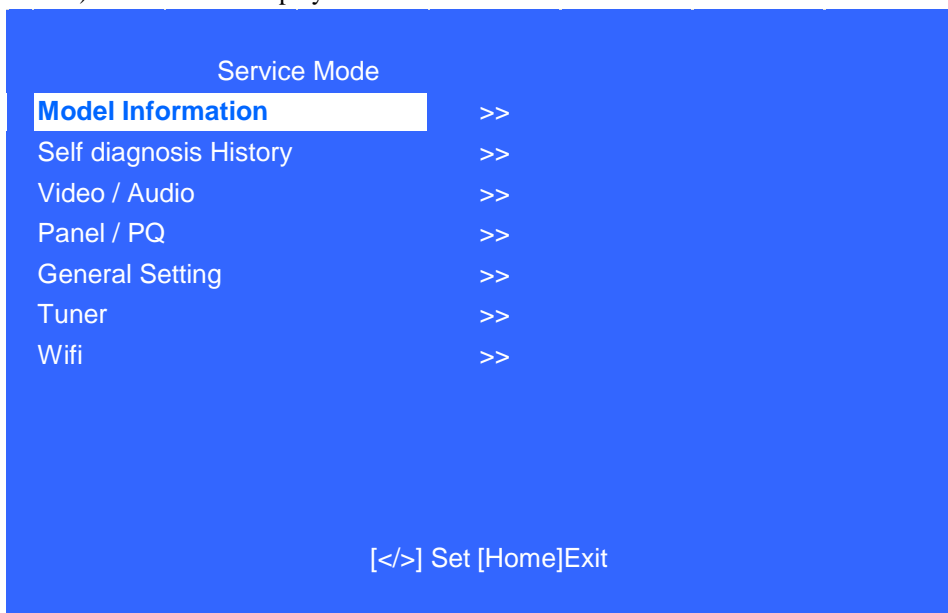

- 4) How to use the remote commander.

Function	The flow of control
Service mode on	<Display><5><Vol Up><Power>
Service mode off	<MENU>/<HOME>
Item up / down	<↑>/<↓>
Item select left/right	<←>/<→>
Execute	<OK>

- 5) After entering service mode, then turn off the power switch.

Summary of key behavior

Key	Behavior
Menu	Close service menu
Cursor/Enter	Return Previous page, Change potion of focus item, Enter next page of focus item, etc..
Return	Return to previous page, close service menu etc..

SOFTWARE VERSION

1) In Service Mode, select “Model Information”, press “Enter” or “→” button to enter Status Information.

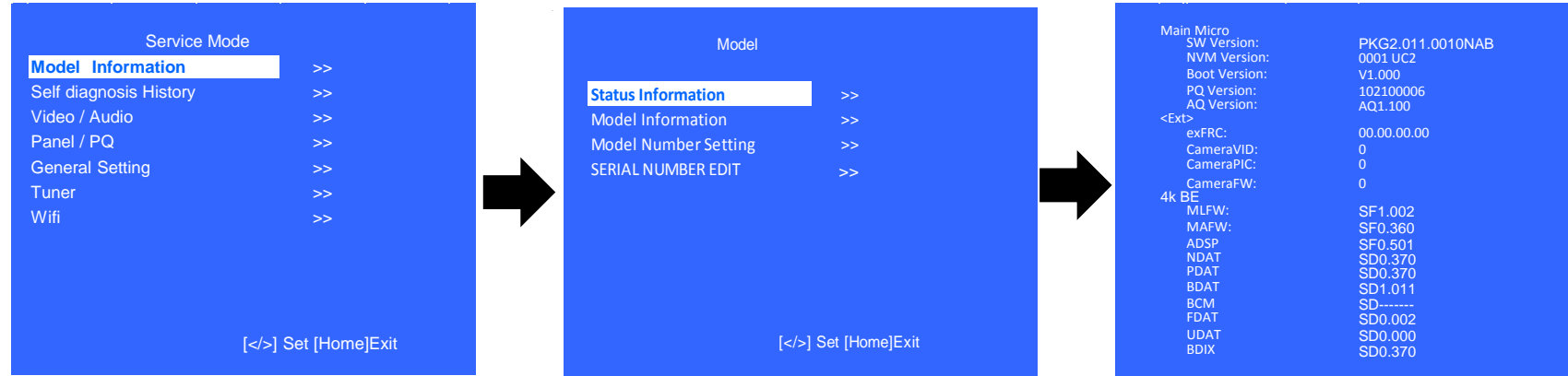

2) Press “Enter” or “Return” button to return to Service Mode.

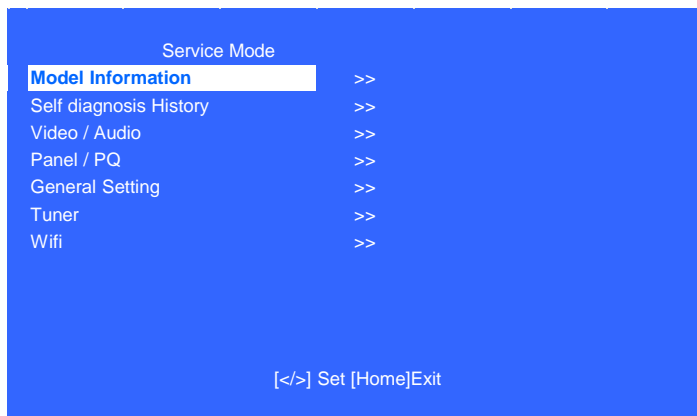

SERIAL NUMBER EDIT (1)

- 1) In “Service Mode”, select “Model Information” by pressing “↑” or “↓” then pressing “Enter” or “→” button to enter inside.
- 2) Select “Serial Number Edit” by pressing “↑” or “↓” button then pressing “Enter” or “→” button
- 3) Press “↑” or “↓” to input numbers.
- 4) After user input data , press <Enter> .
 - Pop-up dialog appear to confirm input data correct
 - **Serial Number can be set ONLY ONCE**
- 5) Press “→” or “←” button to select YES or NO. Select YES if input data is correct. Select NO if input data is incorrect. Press <Enter> to save answer.

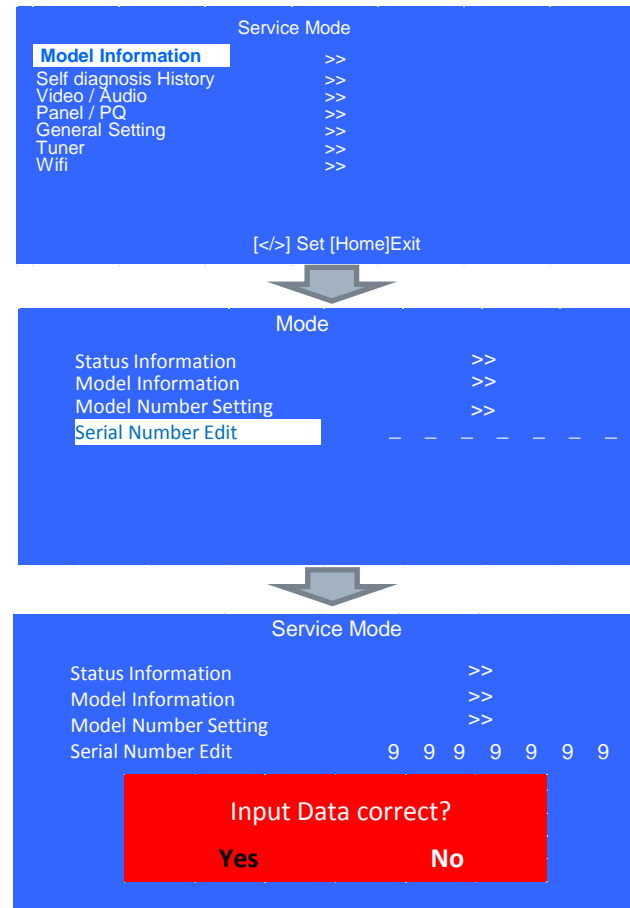

SERIAL NUMBER EDIT (2)

If **YES is selected**, the input data is saved into EEPROM.

SERIAL NUMBER EDIT is greyed out and the serial number that has been input is displayed.

User will **not able to edit** anymore.

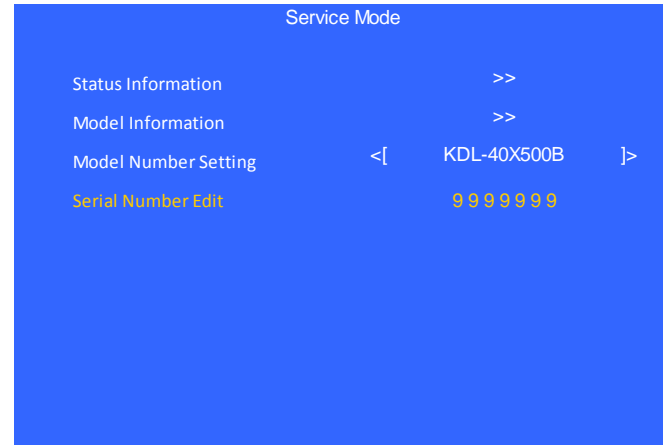

If **NO is selected**, the input data is not saved into EEPROM.

The serial number that has been input is displayed.

User can still edit the Serial Number.

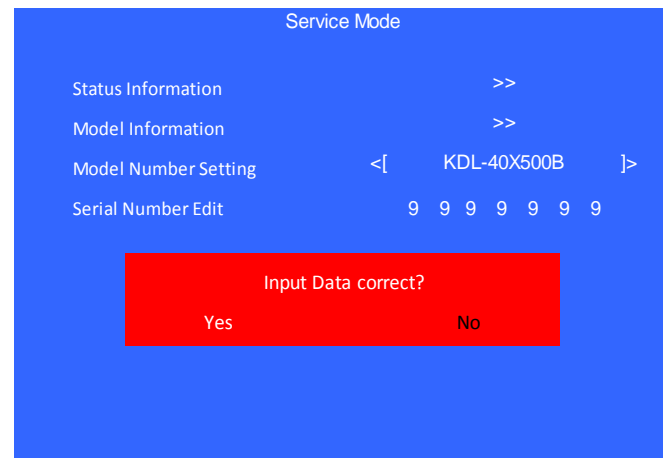

MODEL NUMBER SETTING

- 1) In “Service Mode”, select “Model Information” by pressing “↑” or “↓” then pressing “Enter” or “→” button to enter inside.
- 2) Select “Model Number Setting” by pressing “↑” or “↓” button then pressing “Enter” or “→” button.
- 3) Press “↑” or “↓” arrow key to scroll Product Name Candidate.
 - (e.g. KDL-40X500B CO1,KDL-40X500C BR6)
- 4) Select one Product Name from the list, press <Enter> will pop dialog to inform user to confirm data. Model dependent settings will be overwritten into EEPROM.

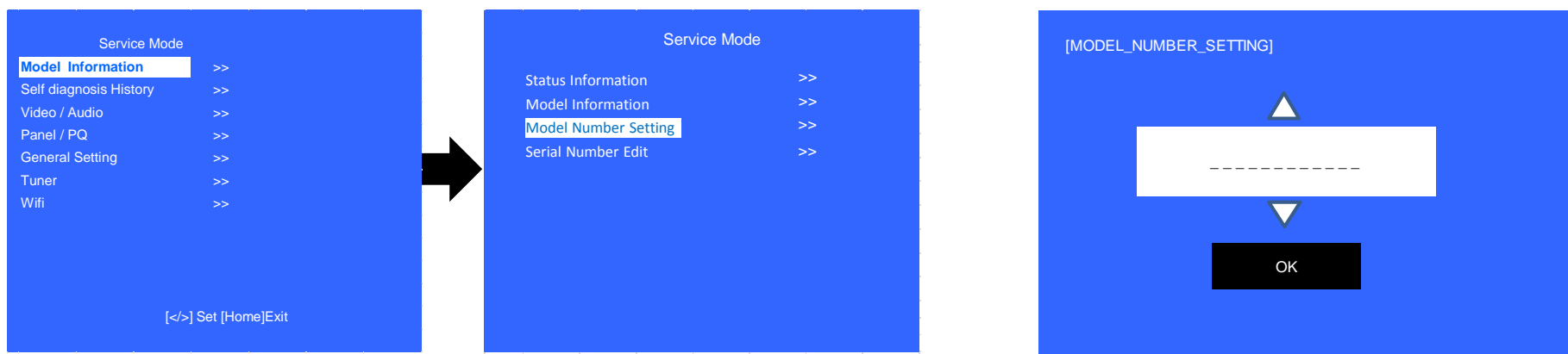

WB ADJUSTMENT

(Please apply when main board or panel is replaced.)

In “Panel/PQ” service mode.

a. Go to “WB Adjustment” category by “↑” or “↓”.

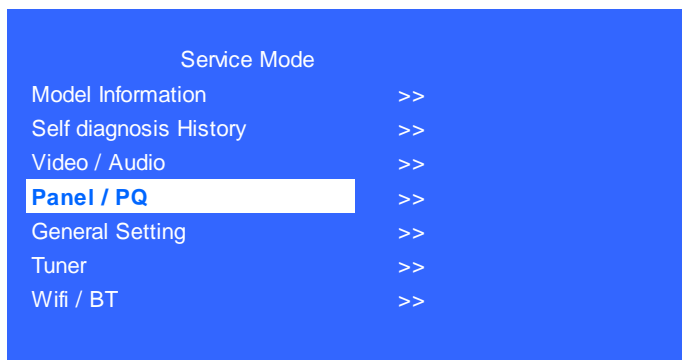

b. To select “WB Adjustment”, press “→” button.

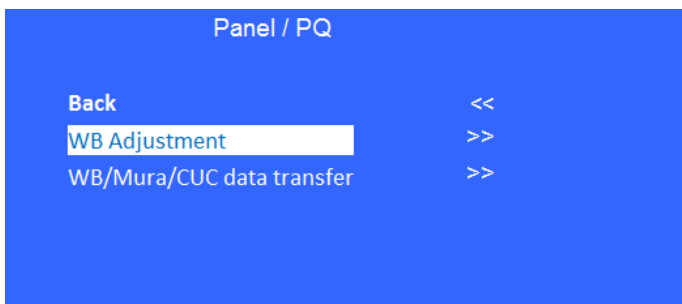

c. To change data , press “←” or “→” on remote commander.



WB/MURA/CUC DATA TRANSFER

(Please apply when main board or panel is replaced.)

1. In “Panel/PQ” service mode.

a. Go to “WB/Mura/CUC data transfer” category by “↑” or “↓”.

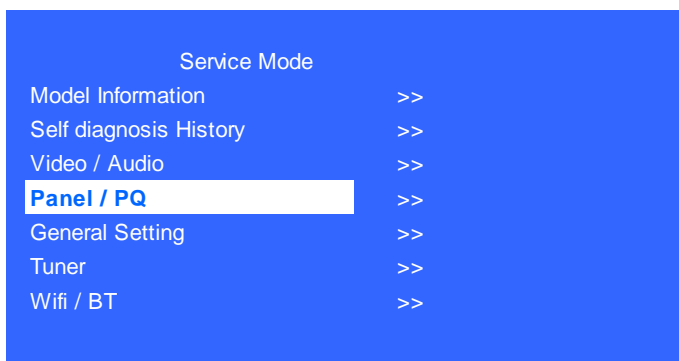

b. To select “WB/Mura/CUC data transfer”, press “→” button.

c. To change data , press “←” or “→” on remote commander.

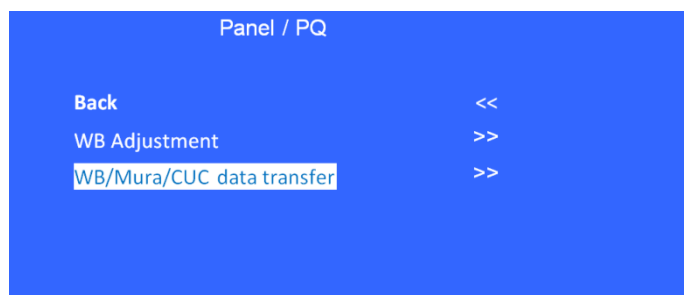

2. In “WB/Mura/CUC data transfer”.

a. Select “WB/Gamma data transfer” by pressing “↑” or “↓” on remote commander.

b. To change the items, press “←” or “→” on remote commander and press “Enter” button.

Selectable items are:

0. SoC to T-con

1. T-con to SoC

2. Not action

c. Select “[start]” and press “Enter” button to start transfer.

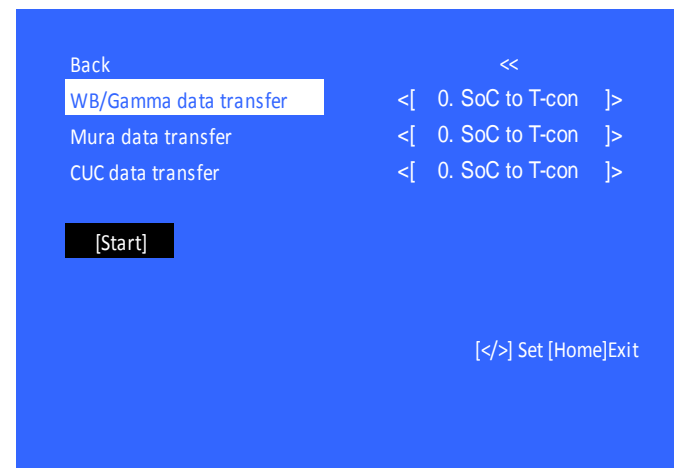

HDD PERFORMANCE CHECK

1. In “Service Mode”, select “General Setting” by pressing “↑” or “↓” then pressing “Enter” or “→” button to enter inside.

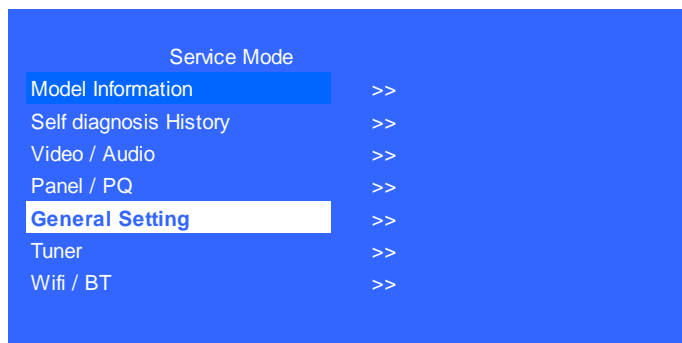

2. Select “HDD Performance check ” by pressing “↑” or “↓” then pressing “Enter” or “→” button to enter inside.

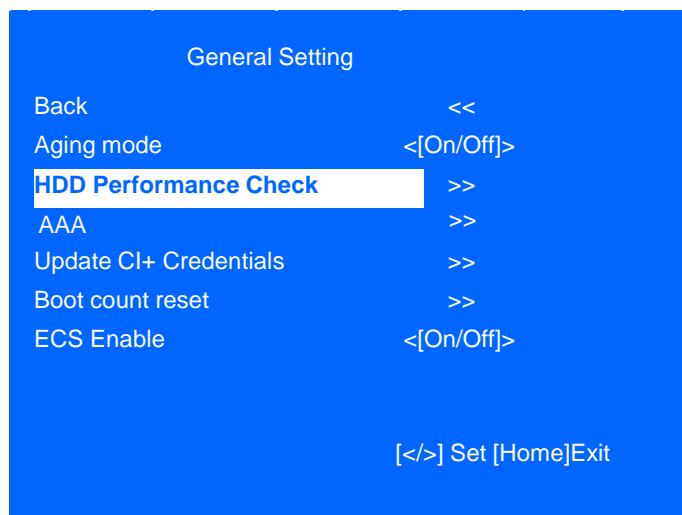

3. A message "Please wait ..." is displayed during performance check processing.

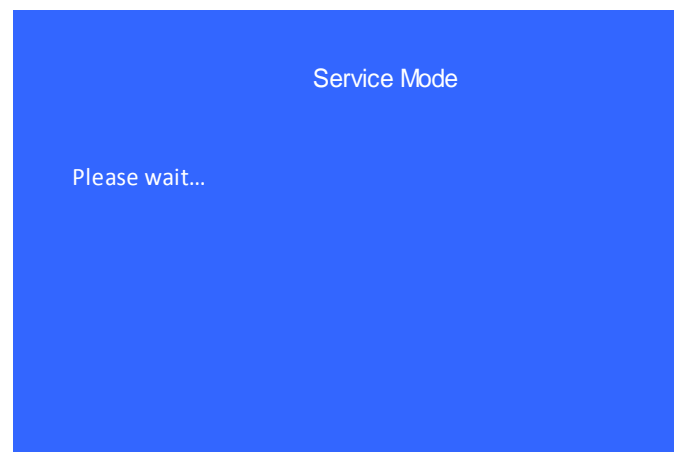

4. Result **OK** or **NG** will be displayed after performance of HDD is checked

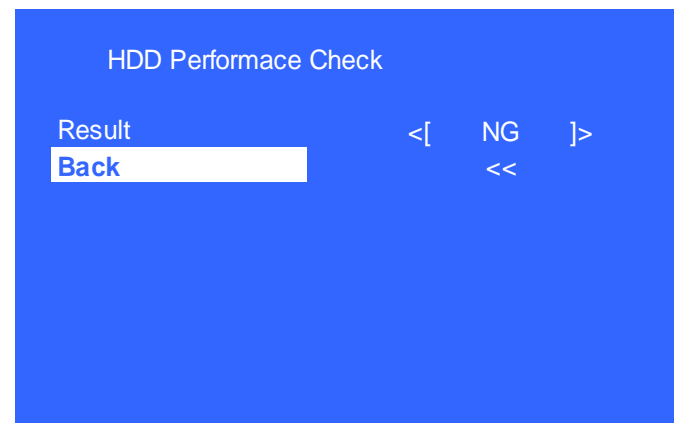

HDD RE-REGISTRATION

- 1) In “Service Mode”, select “General Setting” by pressing “↑” or “↓” then pressing “Enter” or “→” button to enter inside.
- 2) Select “AAA” by pressing “↑” or “↓” then pressing “Enter” or “→” button to enter inside.

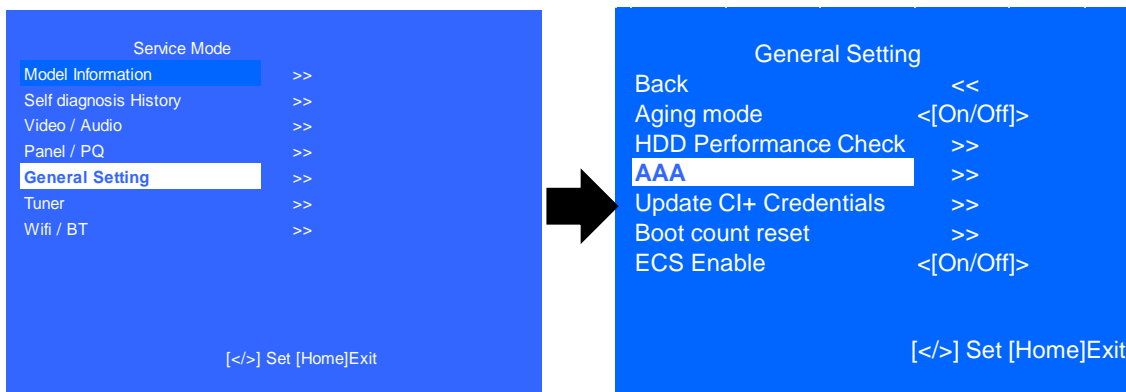

- 3) Result **OK** or **NG** will be displayed after HDD re-registration is succeed/failed.

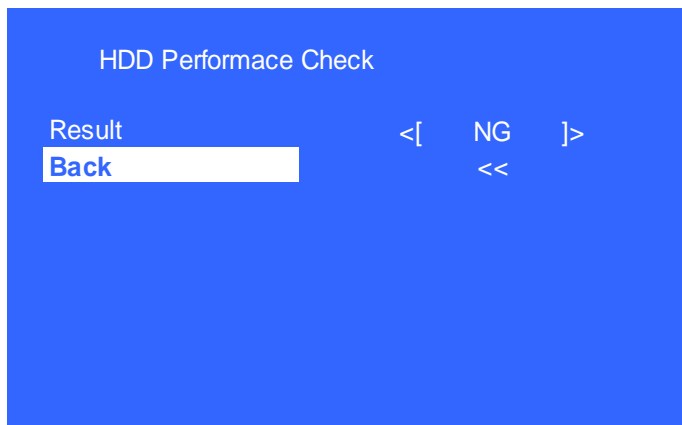

SEC 3. TROUBLE SHOOTING

3-1. TRIAGE

Chart of triage information

1. Confirm the claimed symptom.
2. Select that symptom from the chart.
3. Bring all the boards and cables listed for that symptom.
4. Follow the troubleshooting charts in the technical guides to isolate the board.
5. Chart Color Code.

RED DOT: Most likely defective part

BLUE TRIANGLE: Secondary possible defective part

BLACK TEXT: Board that may correct the symptom

Reference	Symptoms - Shutdown. Power LED blinking red diagnostics sequences									No Power	Video - missing or distorted			Remote	Network	Audio	Skype	Smart Core	Bluetooth (BT)
	2	3	4	5	6	7	8	9	10	No White Power LED & does not reponse to remote (Dead Set)	Stationary colored lines or dots	No video One of Inputs	No video all Inputs	No Remote	Wireless can't connect	No Audio	Skype Can't Work	Smart Core no LED (Set is still alive)	Bluetooth / One Step Remote (OSR) can't connect
B* Board	▲	●	▲	▲	▲	●	●			▲	▲	●	●	▲	▲	●	▲	▲	▲
G* Board	●	▲	▲	▲	●					●						▲			
H* Board										▲				●				●	
K* Board		▲														●			
Speaker		▲														●			
Wifi & BT Module							●								●		▲		●
LD* Board			●									▲							
V By One FFC				▲							▲	▲							
Tcon				●					▲		▲	▲							
LCD Panel			▲	●	●	▲					●		▲						
Problem	Power	Power	LD	Panel (Communication)	Panel (Backlight)	TEMP	Software		Emitter										
		Audio				Local UART													
		Local I2C																	

3-2. NO POWER

3-2-1. NO POWER-PCU

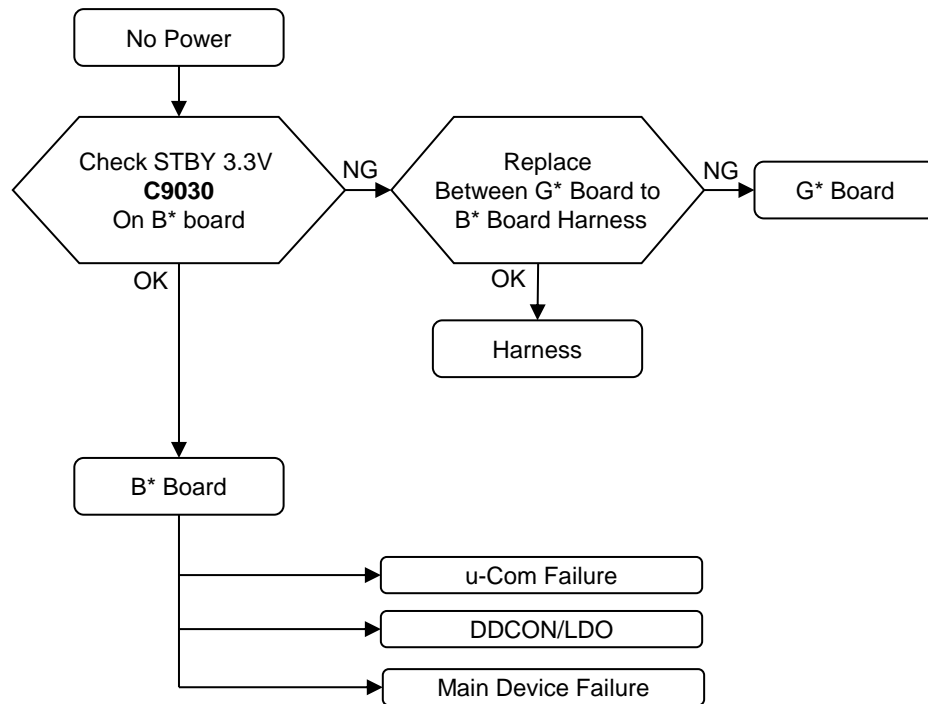

3-2-2. NO POWER-U-Com Failure (1/2)

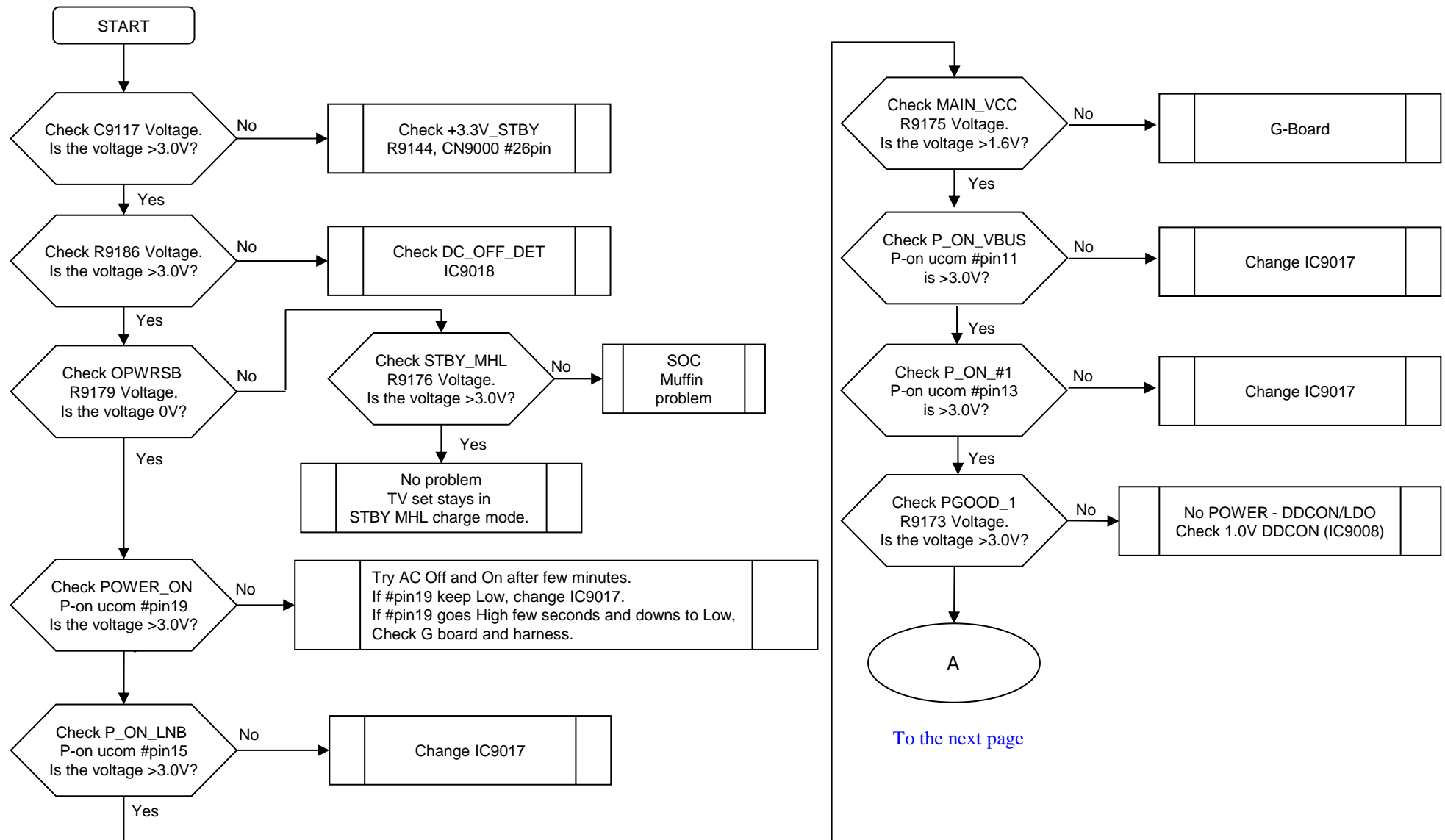

3-2-2. NO POWER-U-Com Failure (2/2)

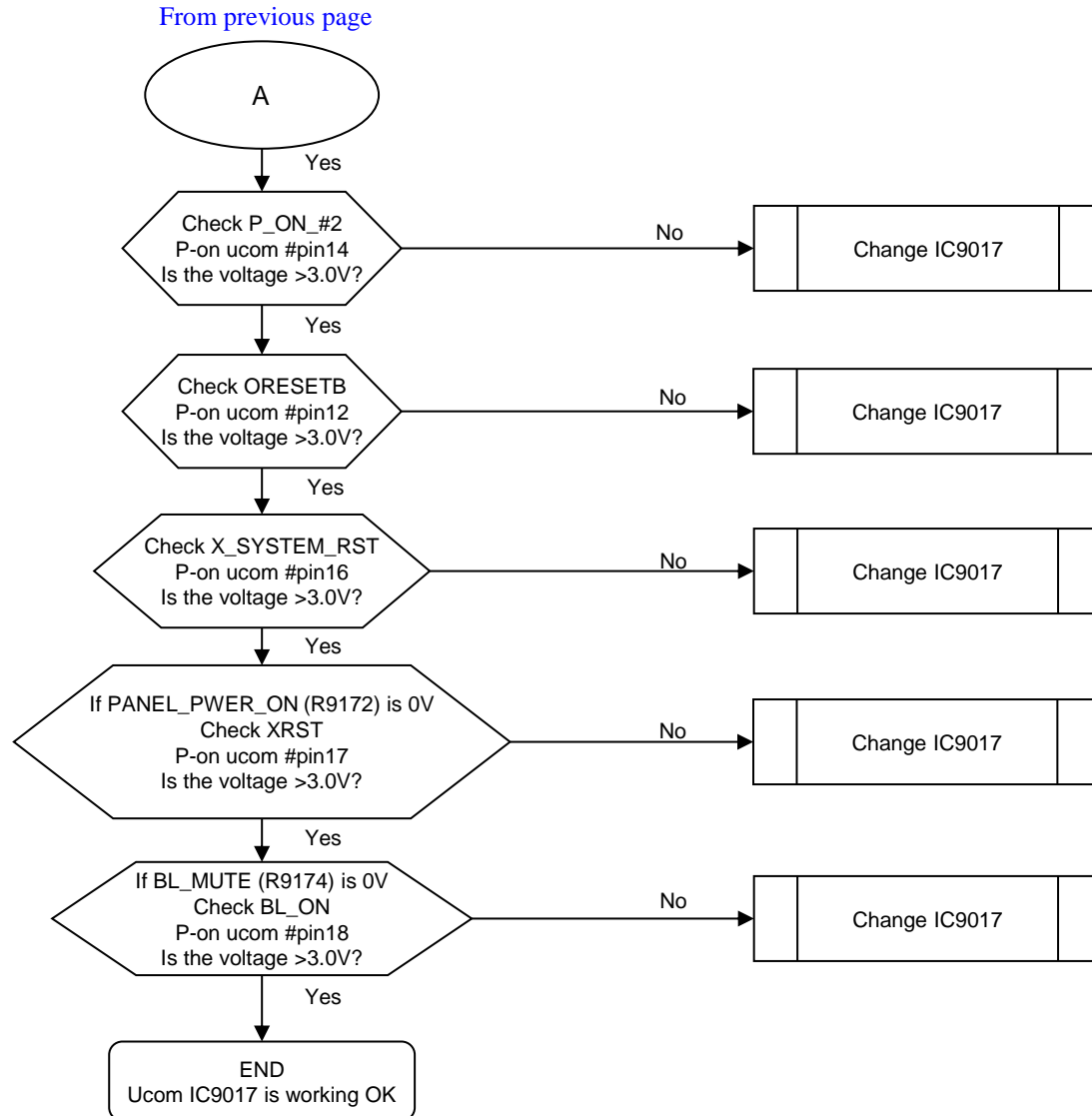

3-2-3. NO POWER: DC_OFF_DET check

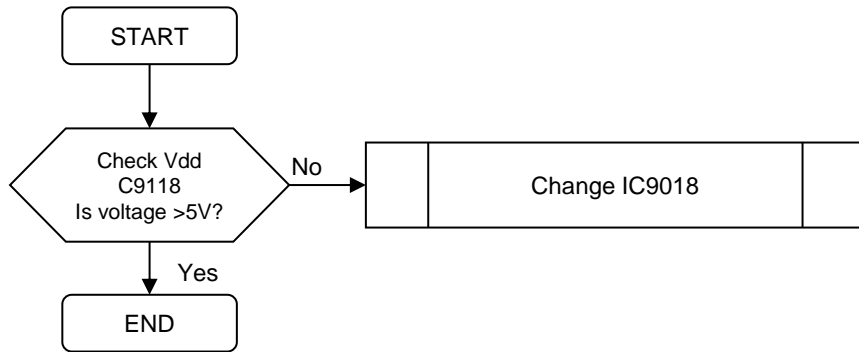

3-2-4. NO POWER: DDCONs check

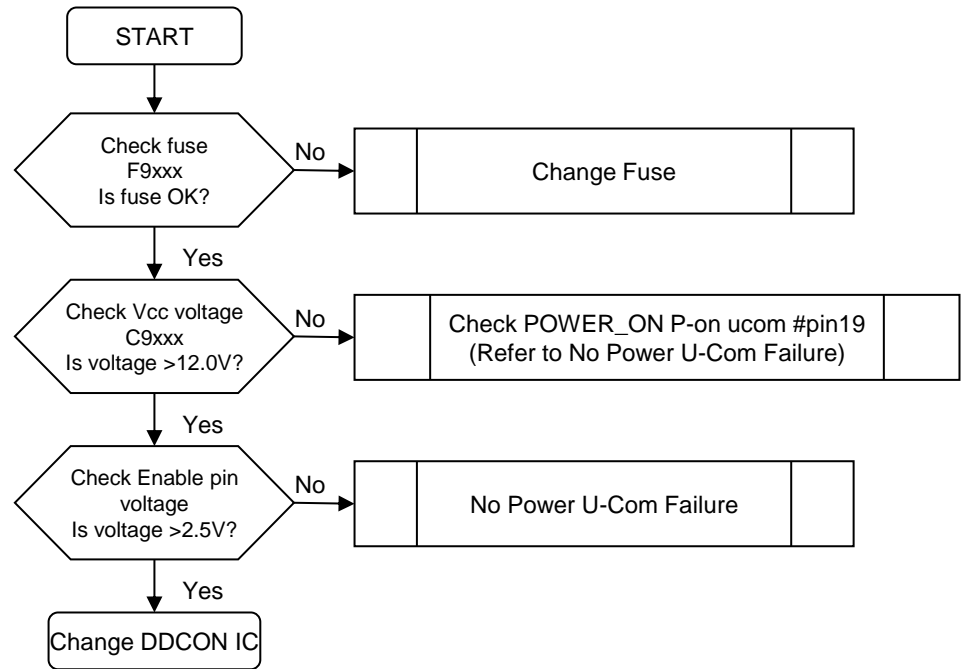

3-2-5. NO POWER: DDCON check

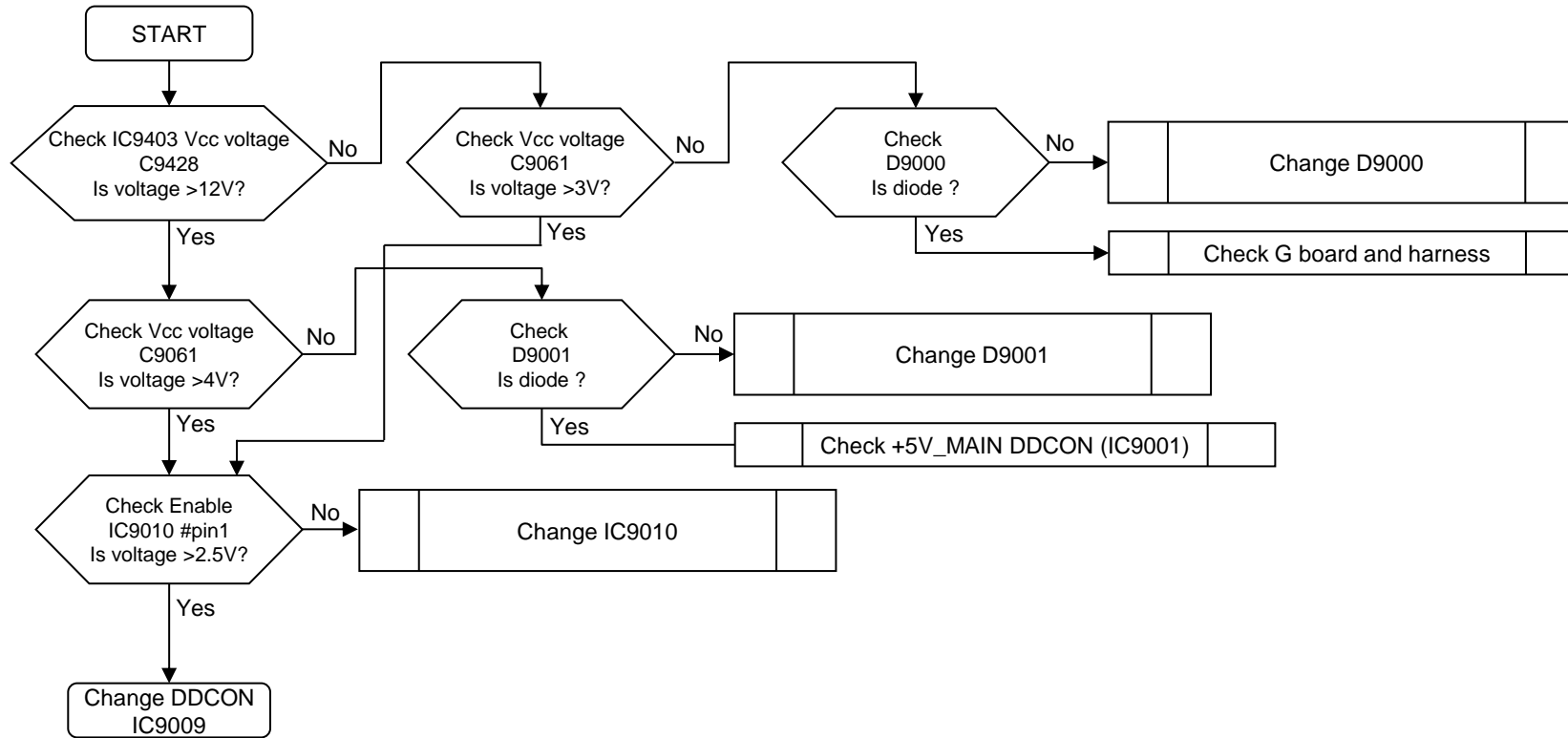

3-2-6. NO POWER: LDOs check check

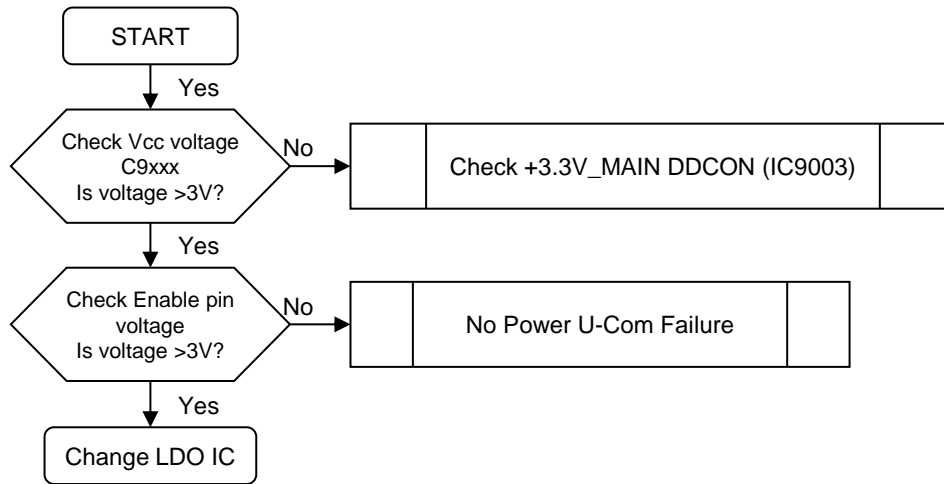

3-3. STANDBY LED BLINKING

3-3-1. 2 Times Blinking (Main power Error)

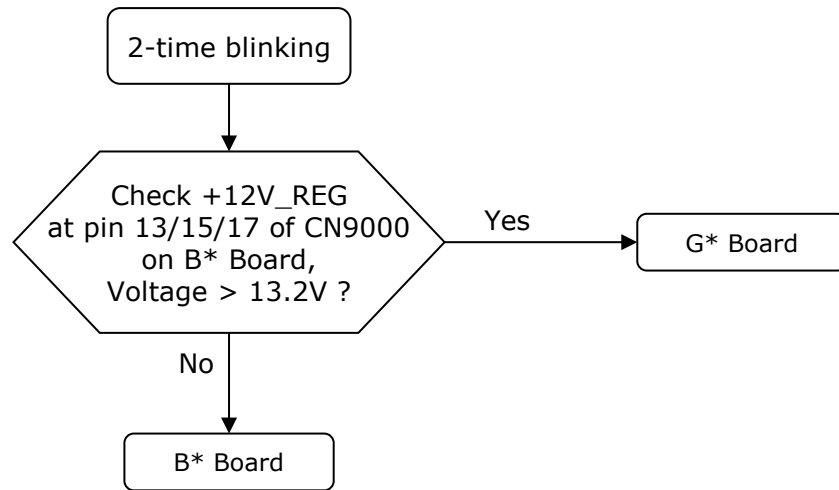

3-3-2. 3 Times Blinking (DC Alert)

BMFL/BMFW board

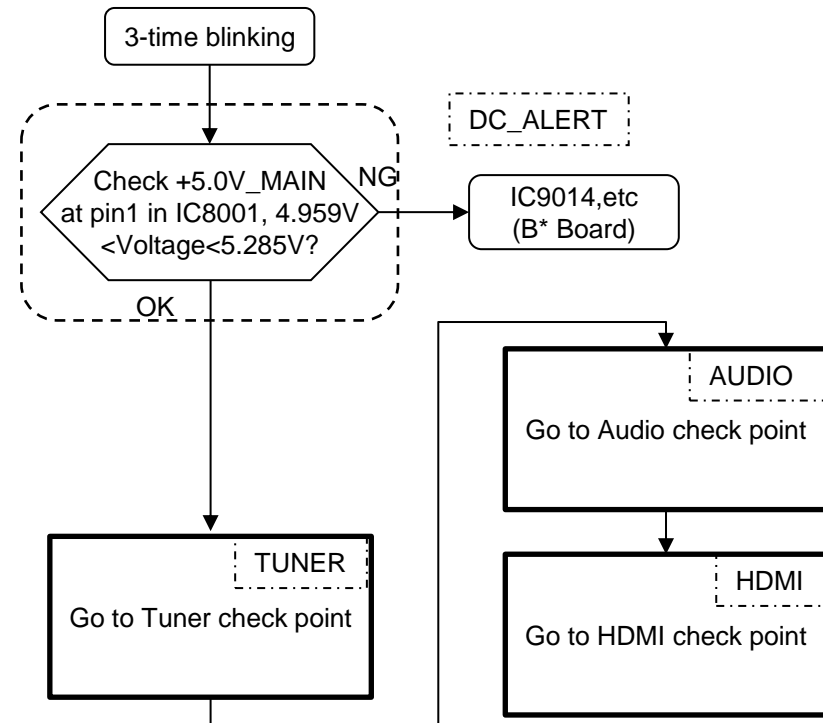

3-3-3. 3 Times Blinking (Tuner Error)

BMF* board

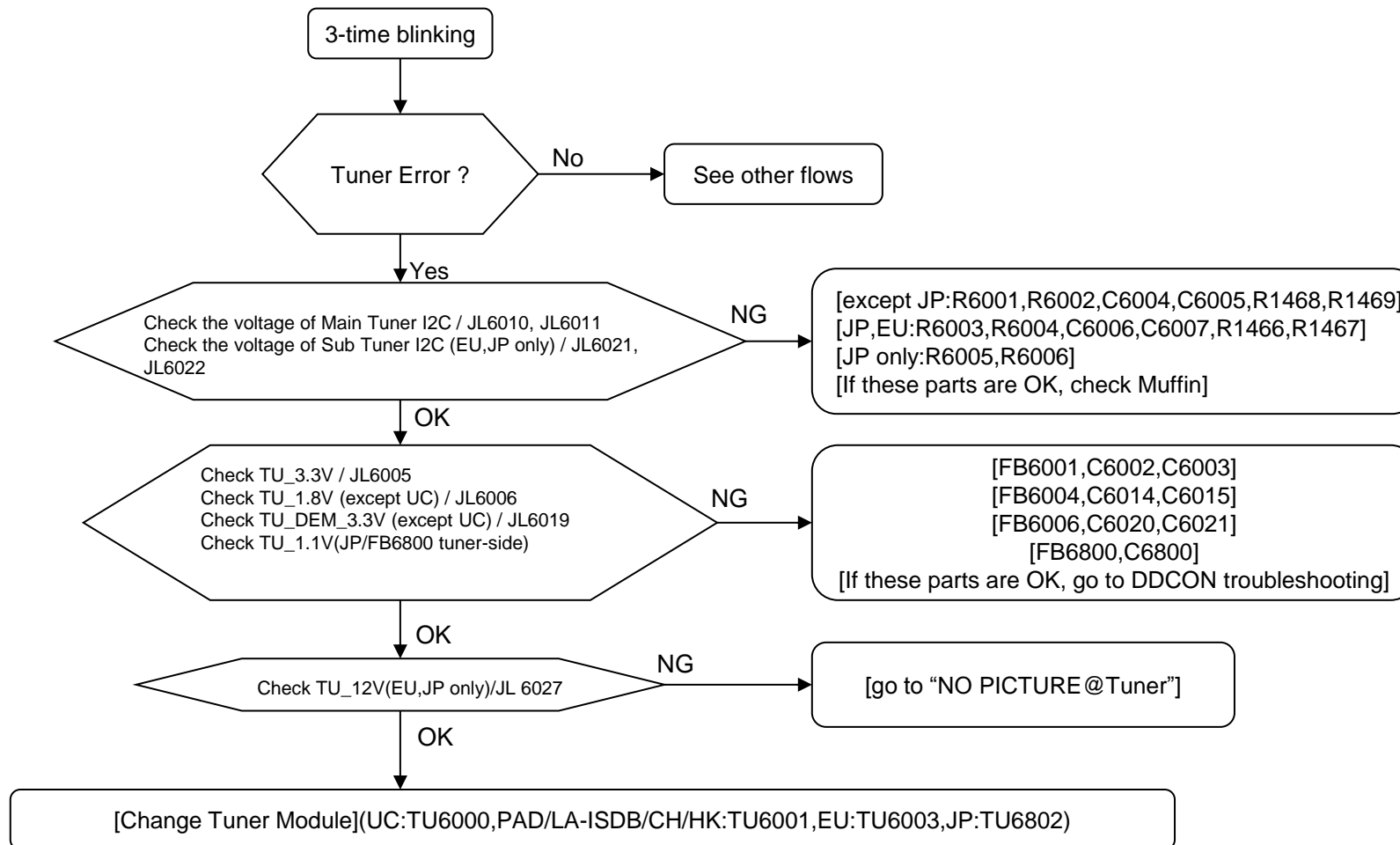

3-3-4. 3 Times Blinking (Audio Error)

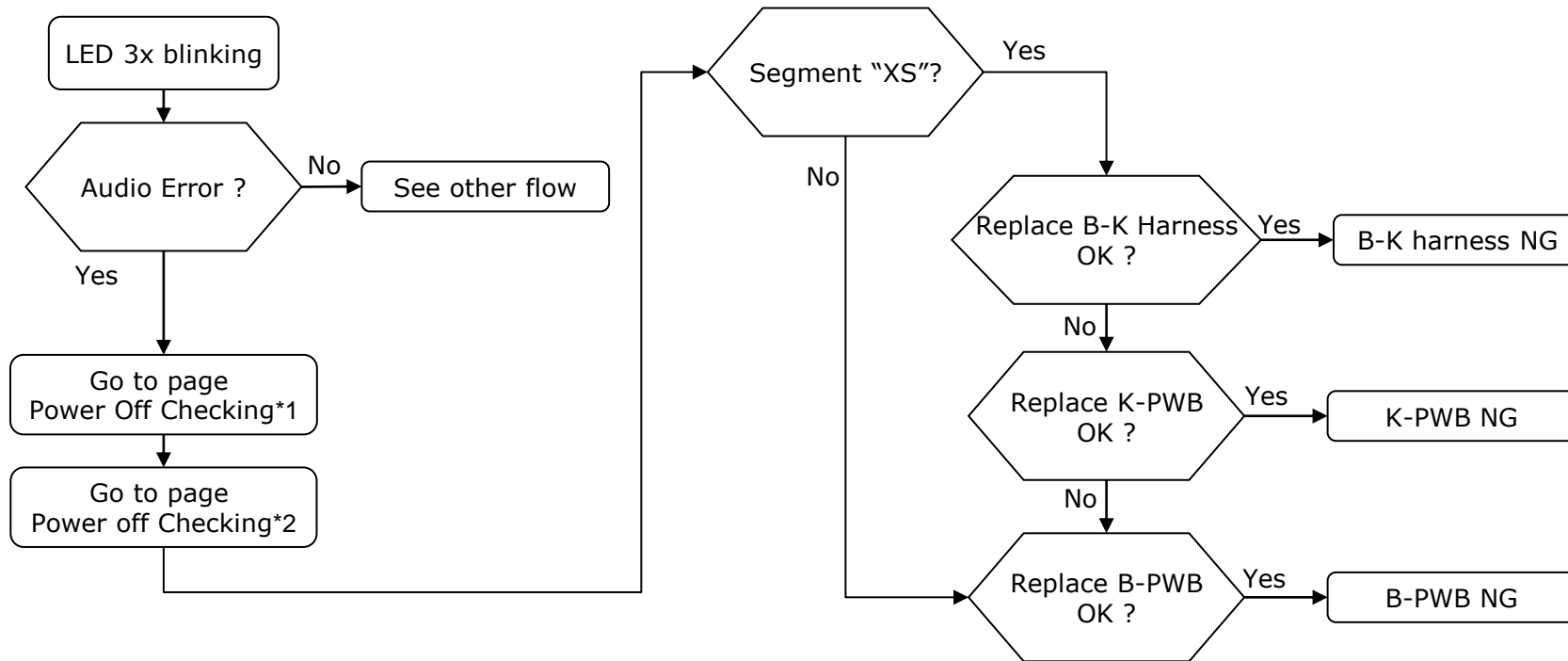

1) Power Off Checking*1

Note 1:

(1) PVDD-GND short check
Measure impedance between PVDD and GND at C7706, C7707.
If impedance is $<100\Omega$ → NG

(2) LDO out short check
Measure impedance between +3.3V and GND at C9130.
If impedance is $<100\Omega$ → NG

(3) Fuse open check
Measure impedance of fuse F7700, F7702 5A (12.5V)
If fuse open → NG

Note 2:

(1) PVDD-GND short check
Measure impedance between PVDD and GND at C7722, C7762, C7782, C7834.
If impedance is $<100\Omega$ → NG

(2) LDO out short check
Measure impedance between +3.3V and GND at C7909.
If impedance is $<100\Omega$ → NG

(3) Fuse open check
Measure impedance of fuse F7702, F7704, F7705, F7701 5A (12.5V)
F7700 3.15A (DDC5V)
If fuse open → NG

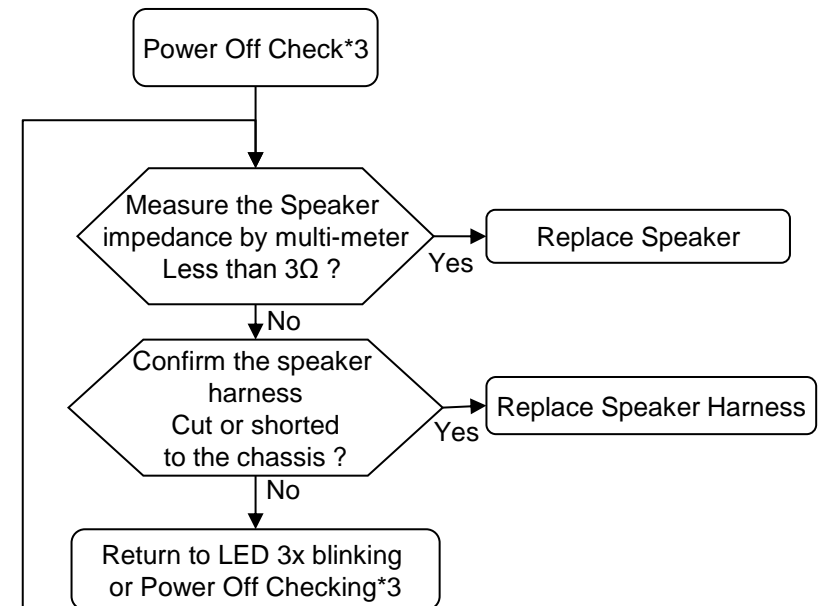
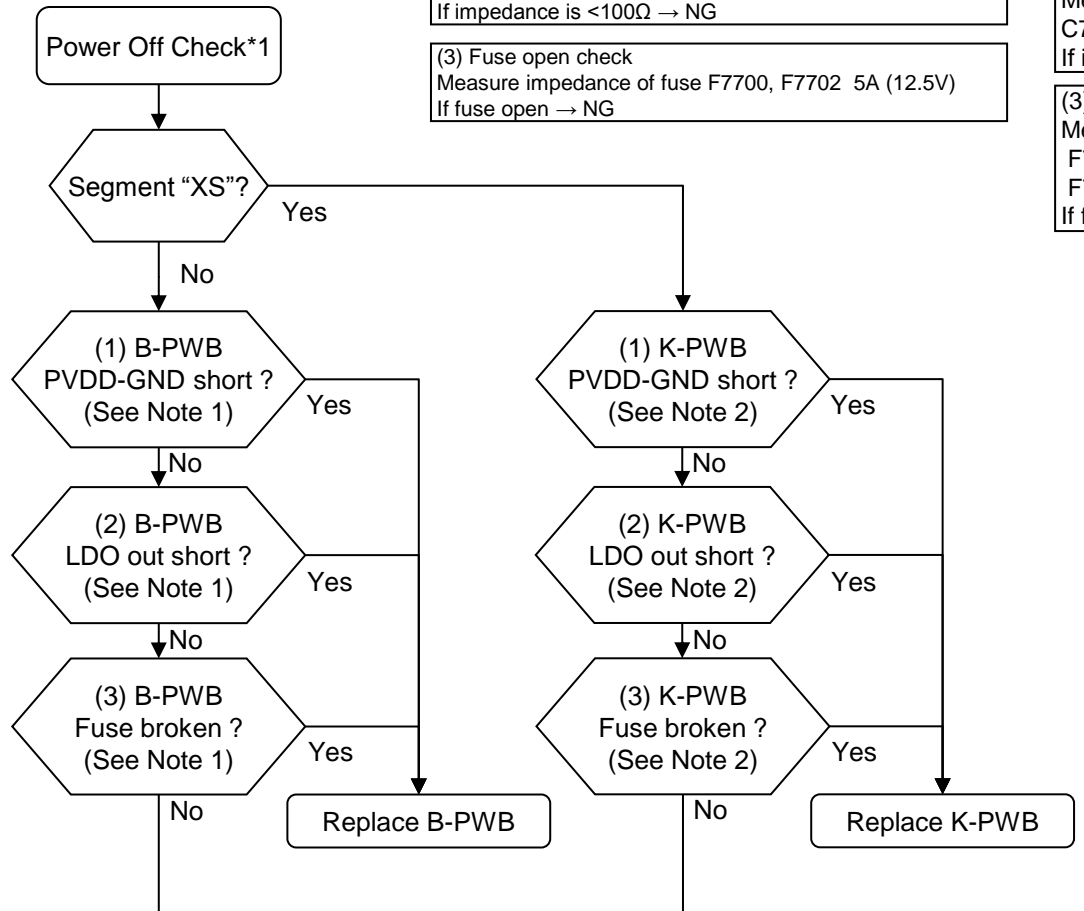

2) Power Off Checking*2

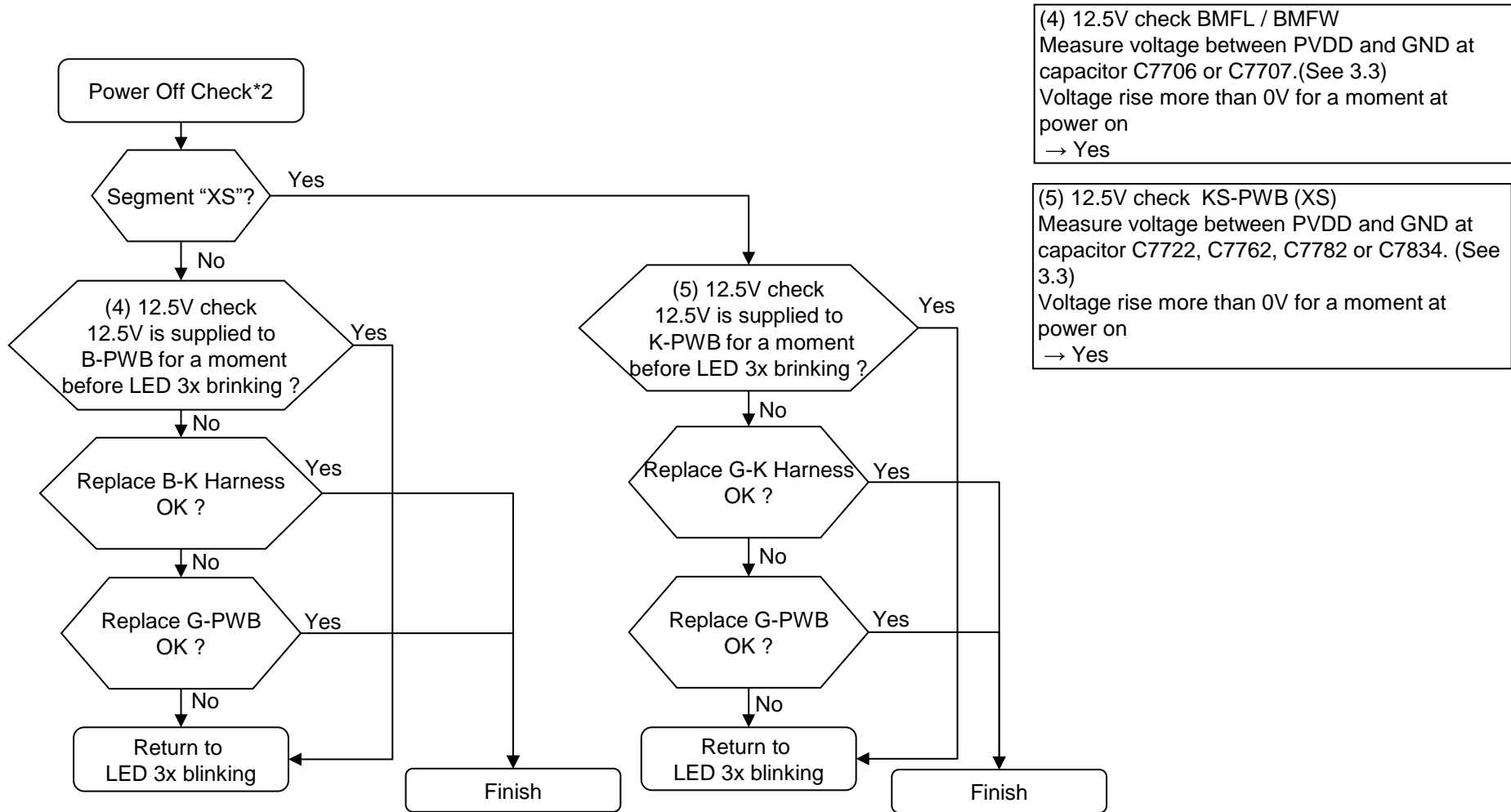

(4) 12.5V check BMFL / BMFW
Measure voltage between PVDD and GND at capacitor C7706 or C7707.(See 3.3)
Voltage rise more than 0V for a moment at power on
→ Yes

(5) 12.5V check KS-PWB (XS)
Measure voltage between PVDD and GND at capacitor C7722, C7762, C7782 or C7834. (See 3.3)
Voltage rise more than 0V for a moment at power on
→ Yes

3) Power Off Checking*3

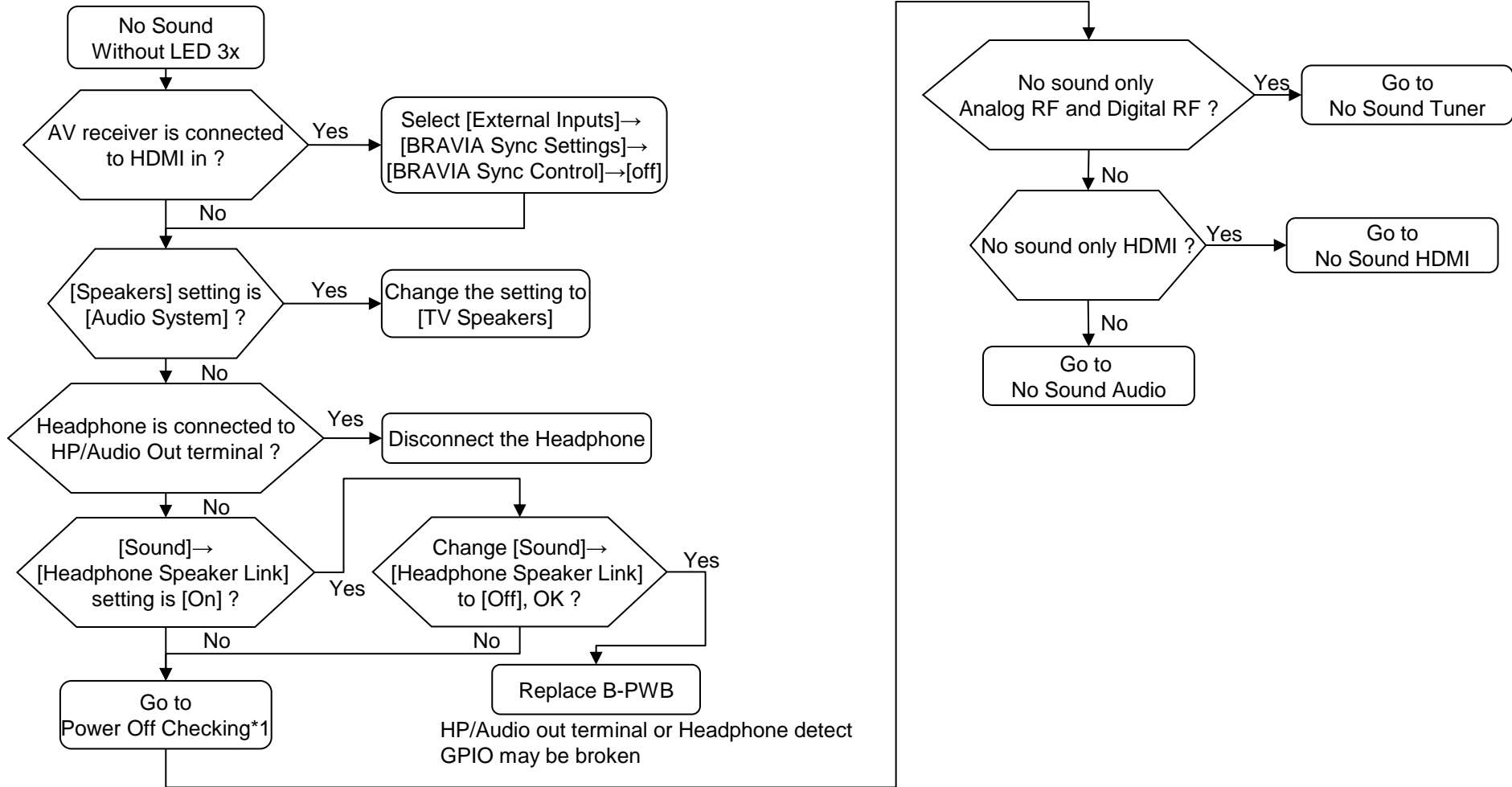

3-3-5. 3 Times Blinking (HDMI EQ Error)

BMFL/BMFW board

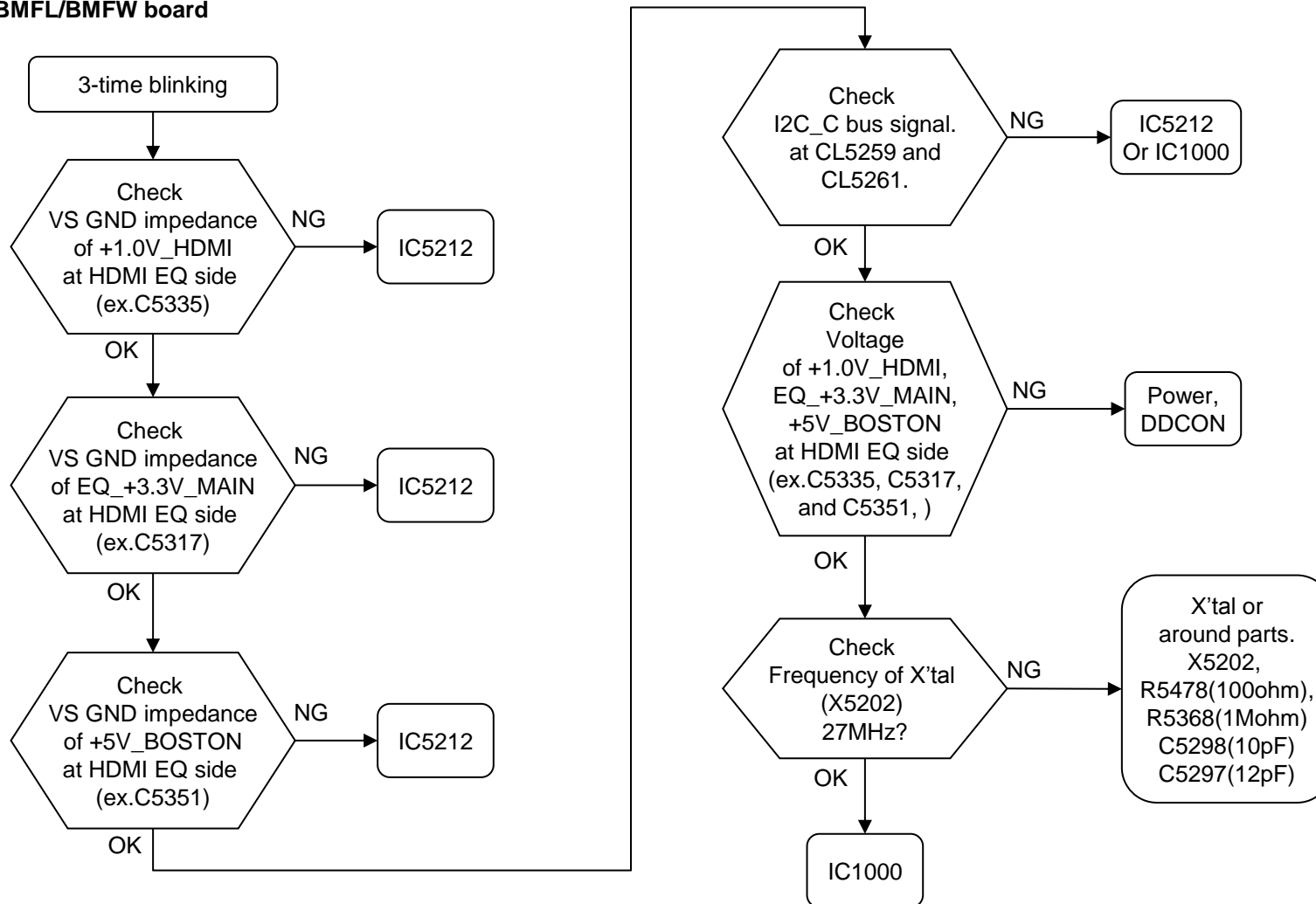

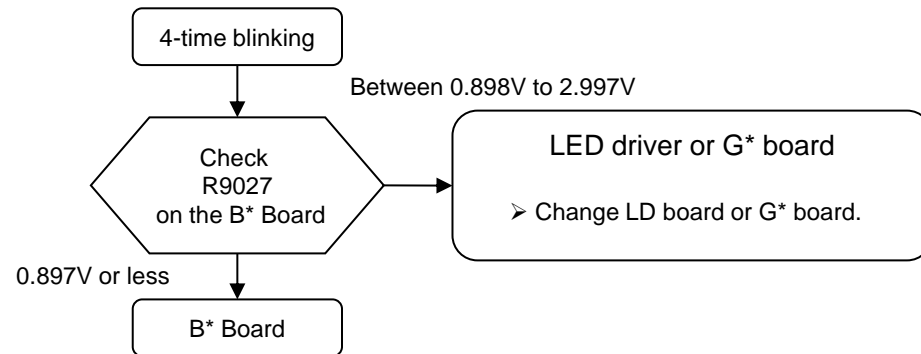
3-3-6. 4 Times Blinking (LED Voltage Error)

3-3-7. 5 Times Blinking (Panel Communication Error)

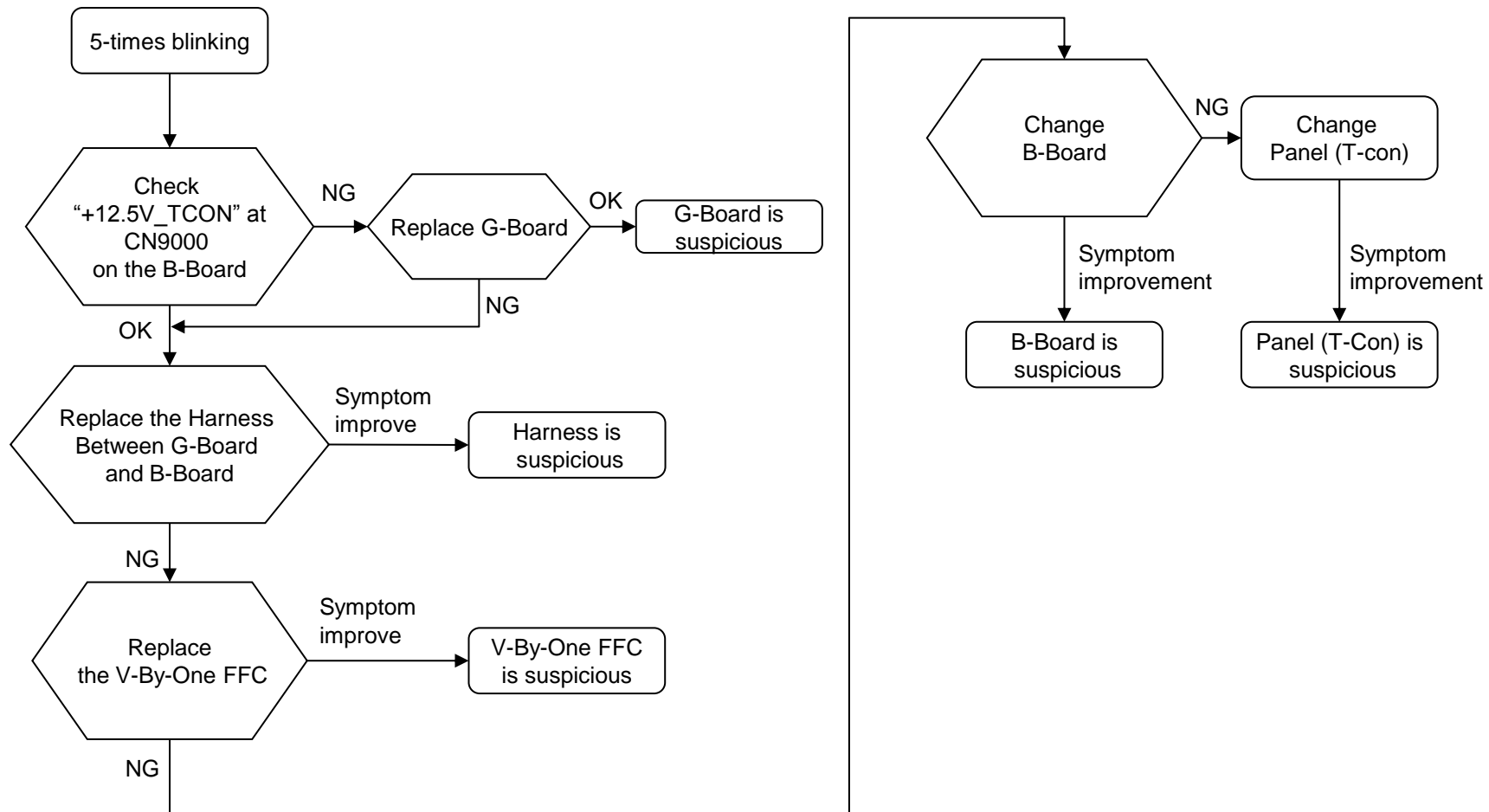

3-3-8. 6 Times Blinking (Backlight Error)

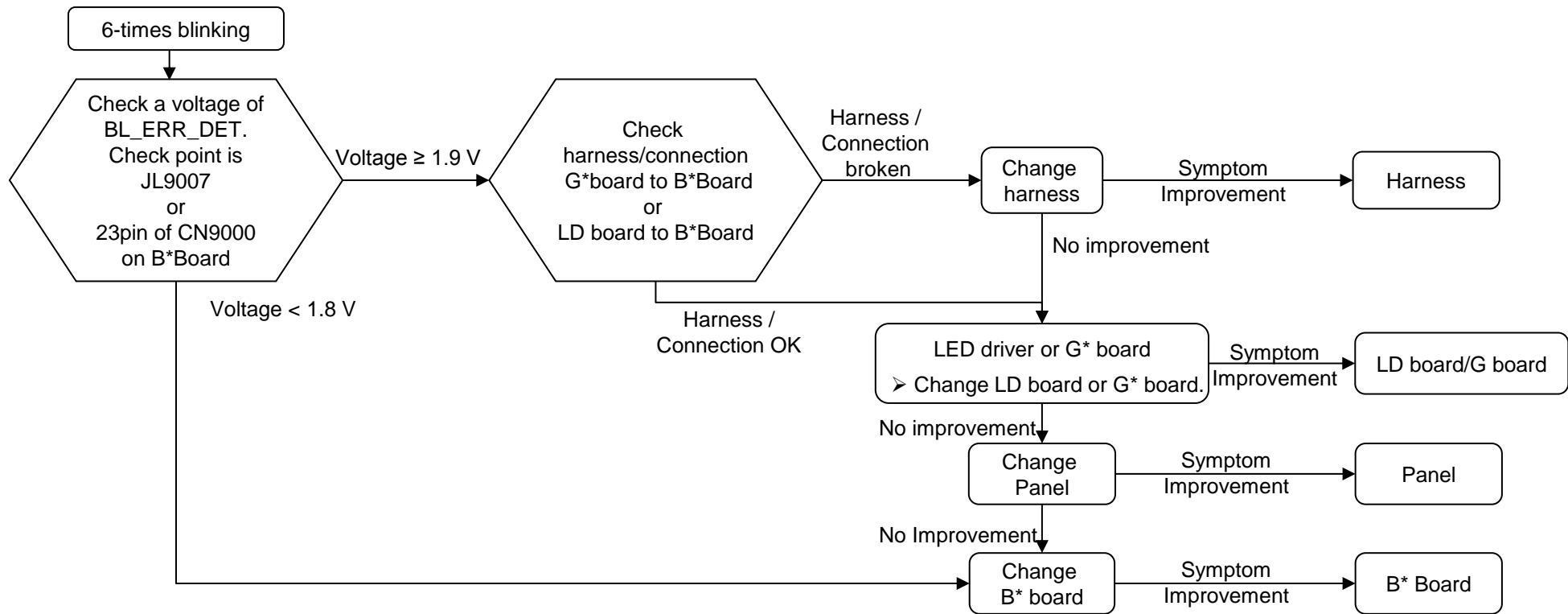

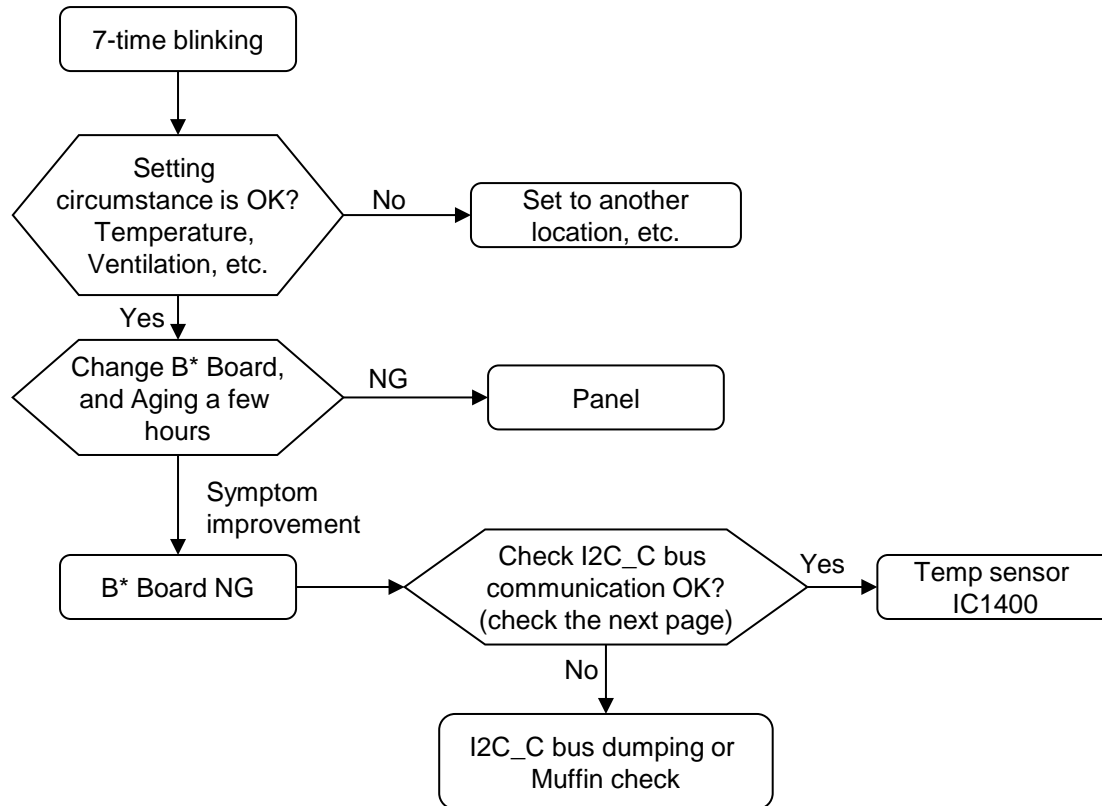
3-3-9. 7 Times Blinking (Temperature Error)

3-4. NO SOUND

3-4-1. No Sound Audio

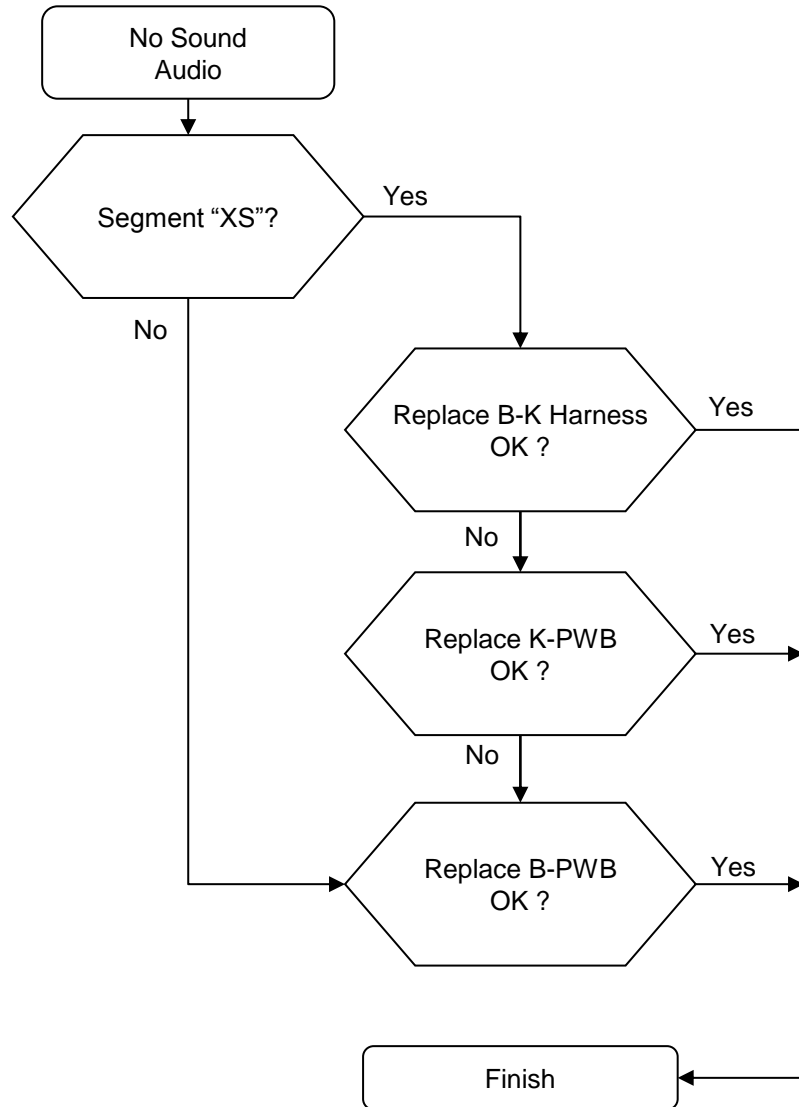

3-4-2. No Sound : TUNER

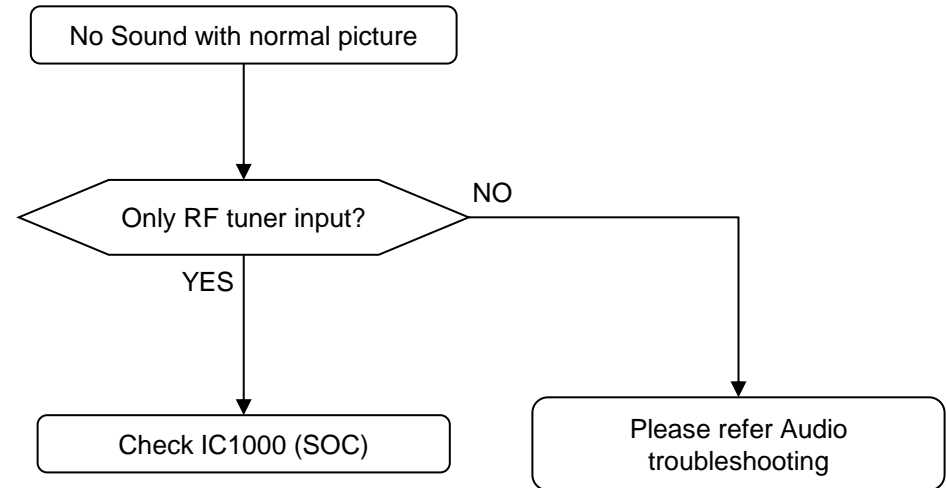

3-4-3. No Sound : MHL

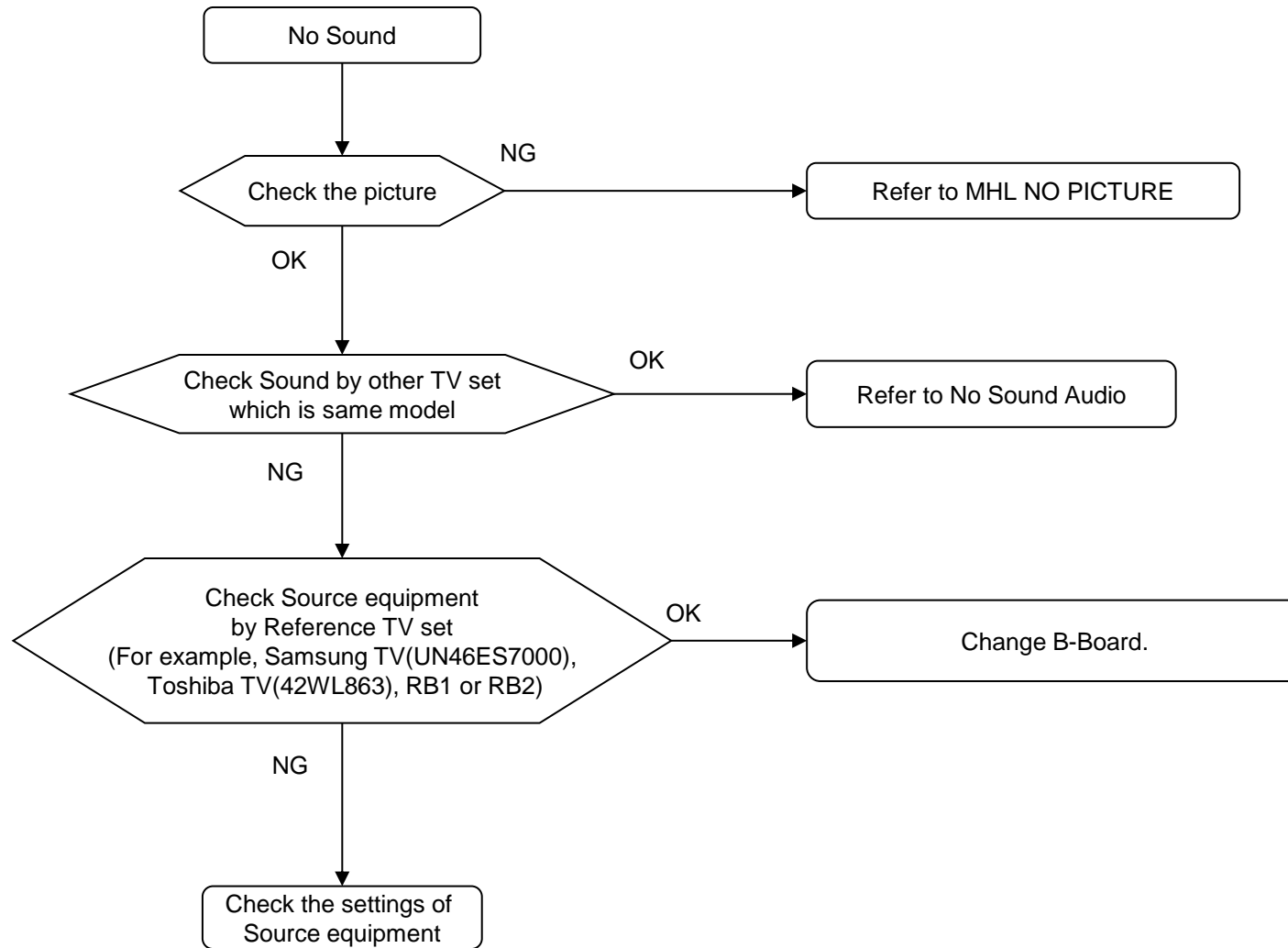

3-4-4. No Sound : HDMI1/2/3/4

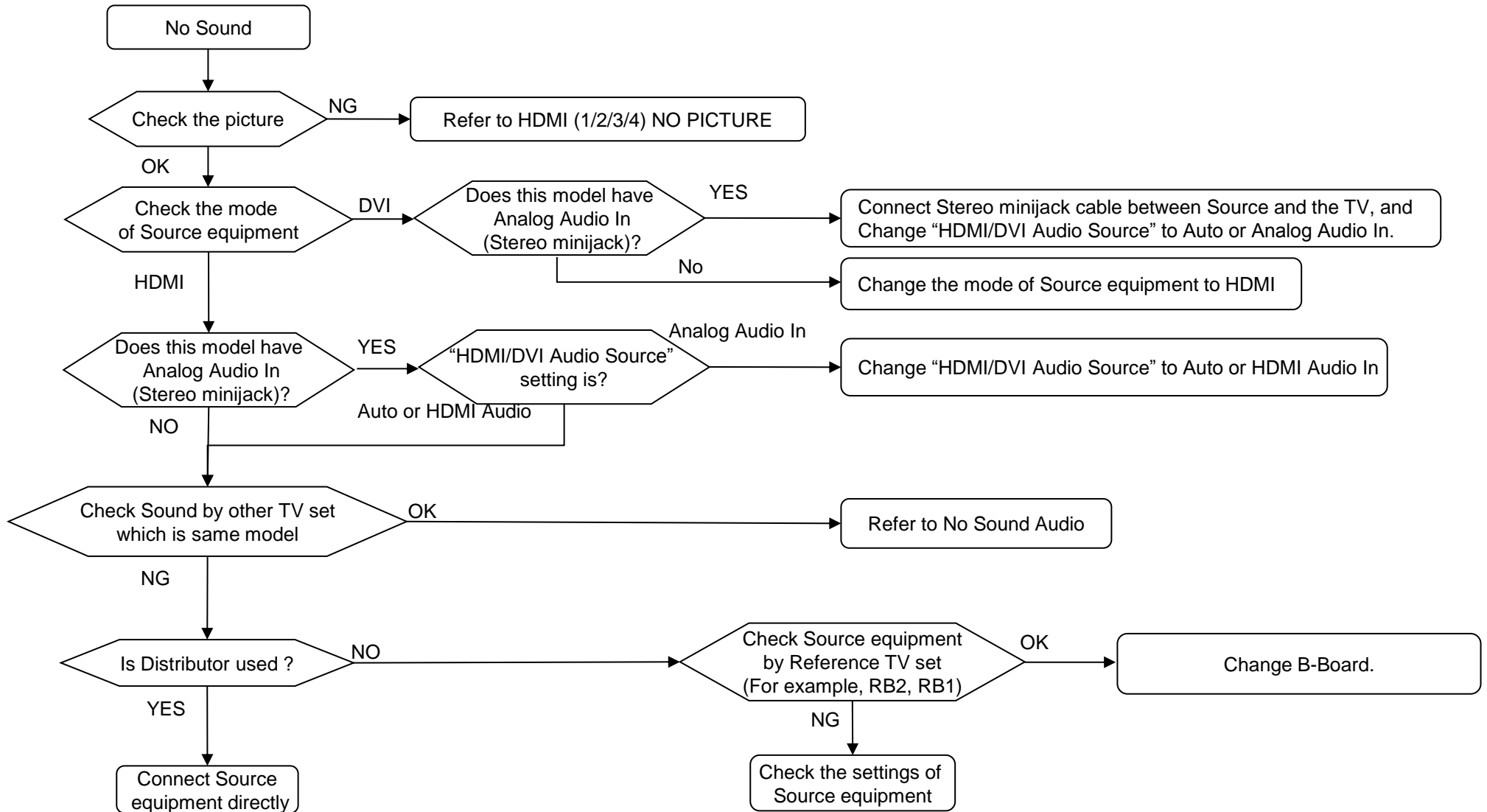

3-5. NO PICTURE

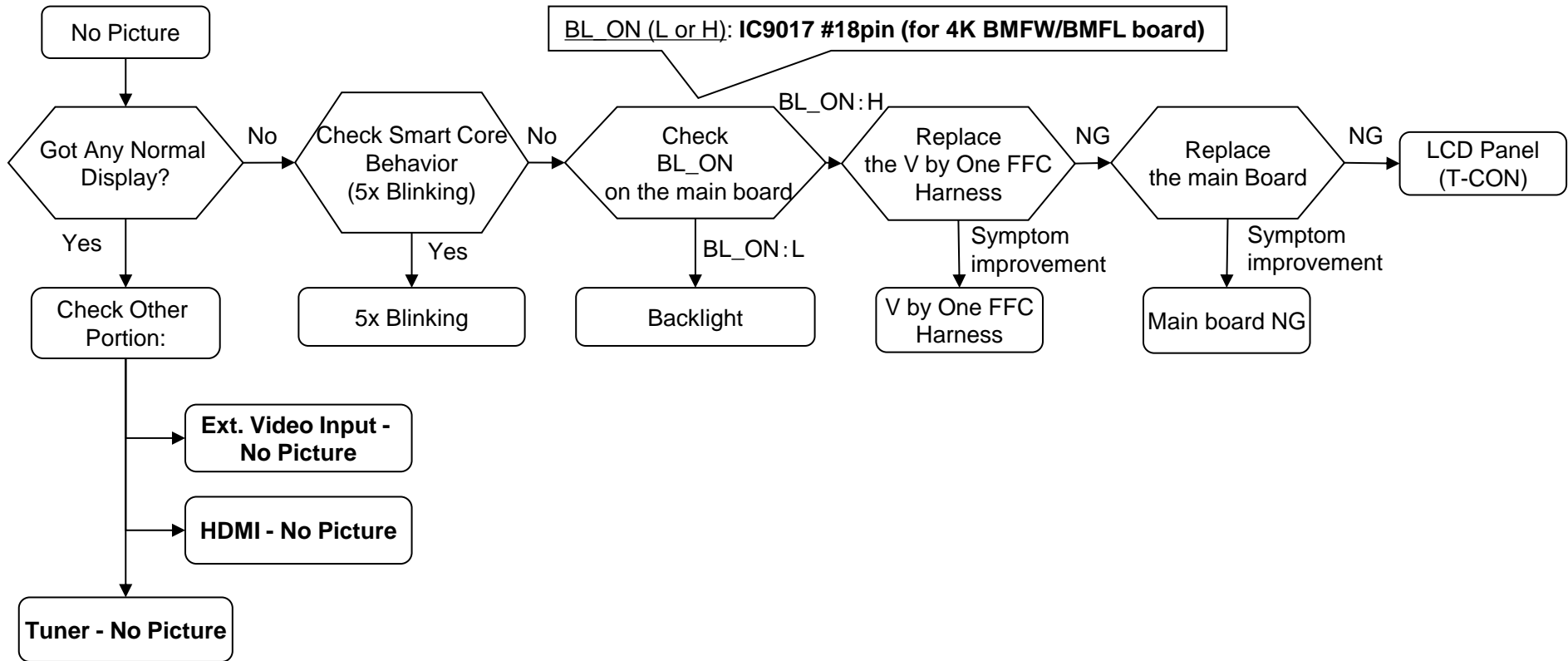

3-5-1. No Picture AEP Destination (BMFL/BMFW) SCART

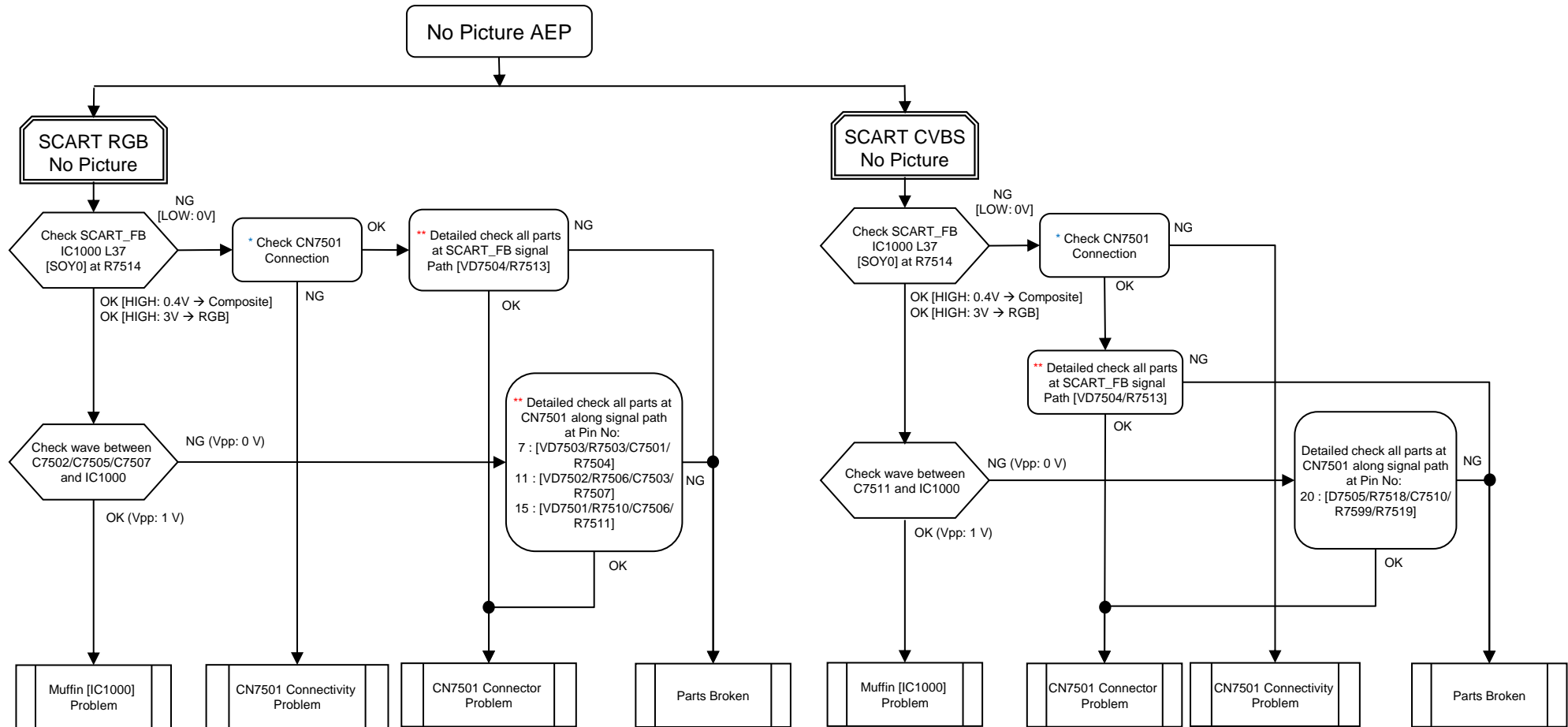

[All voltage measurement using Oscilloscope]

* → OK Condition : No solder splash can be seen
 → NG Condition : Solder splash can be seen

** → OK Condition : No part short-circuited
 → NG Condition : Part short-circuited

3-5-2. No Picture AEP Destination (BMFL/BMFW) VIDEO

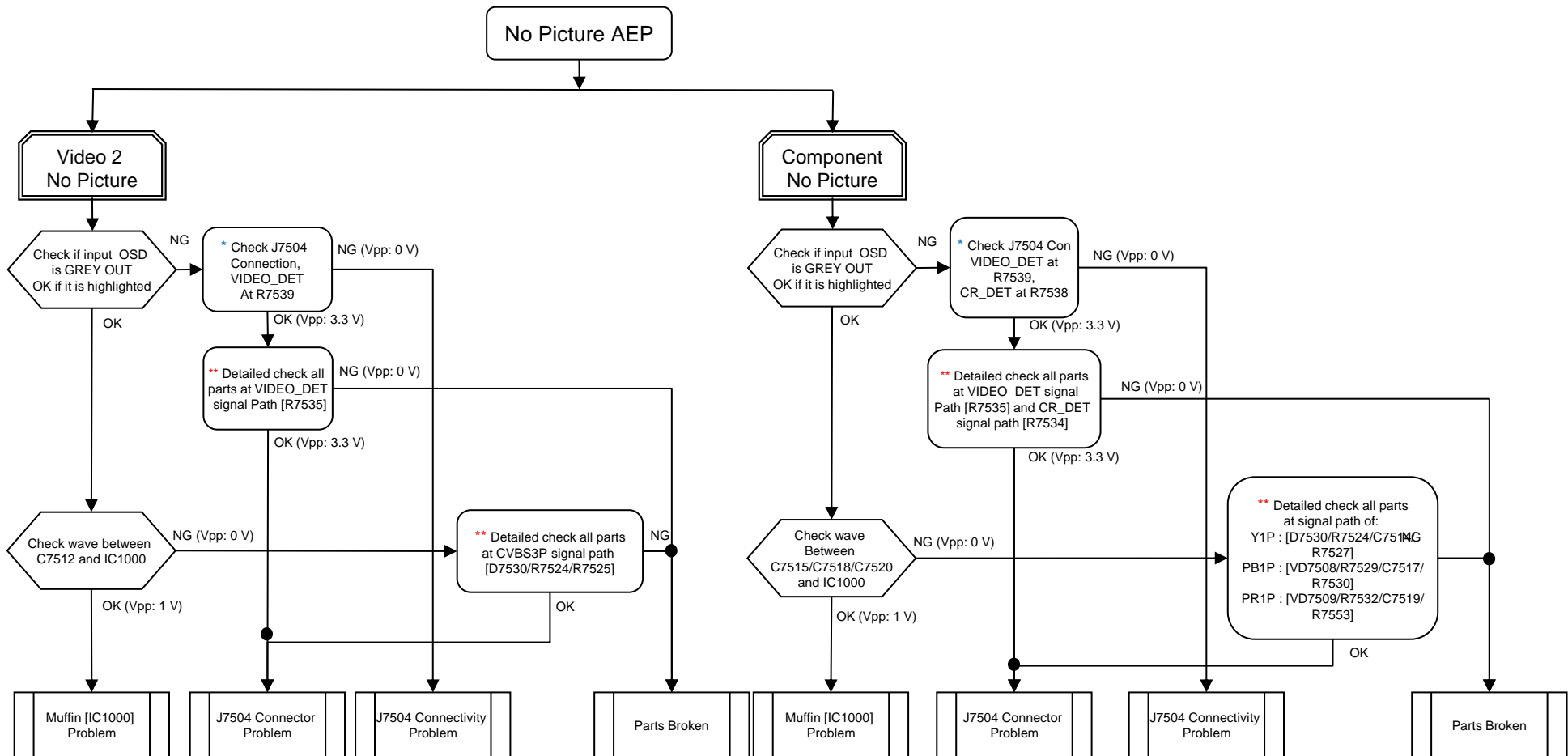

[All voltage measurement using Oscilloscope]

* → OK Condition : No solder splash can be seen
→ NG Condition : Solder splash can be seen

** → OK Condition : No part short-circuited
→ NG Condition : Part short-circuited

3-5-3. No Picture CH/MX/PA/COL/LA (BMFL/BMFW)

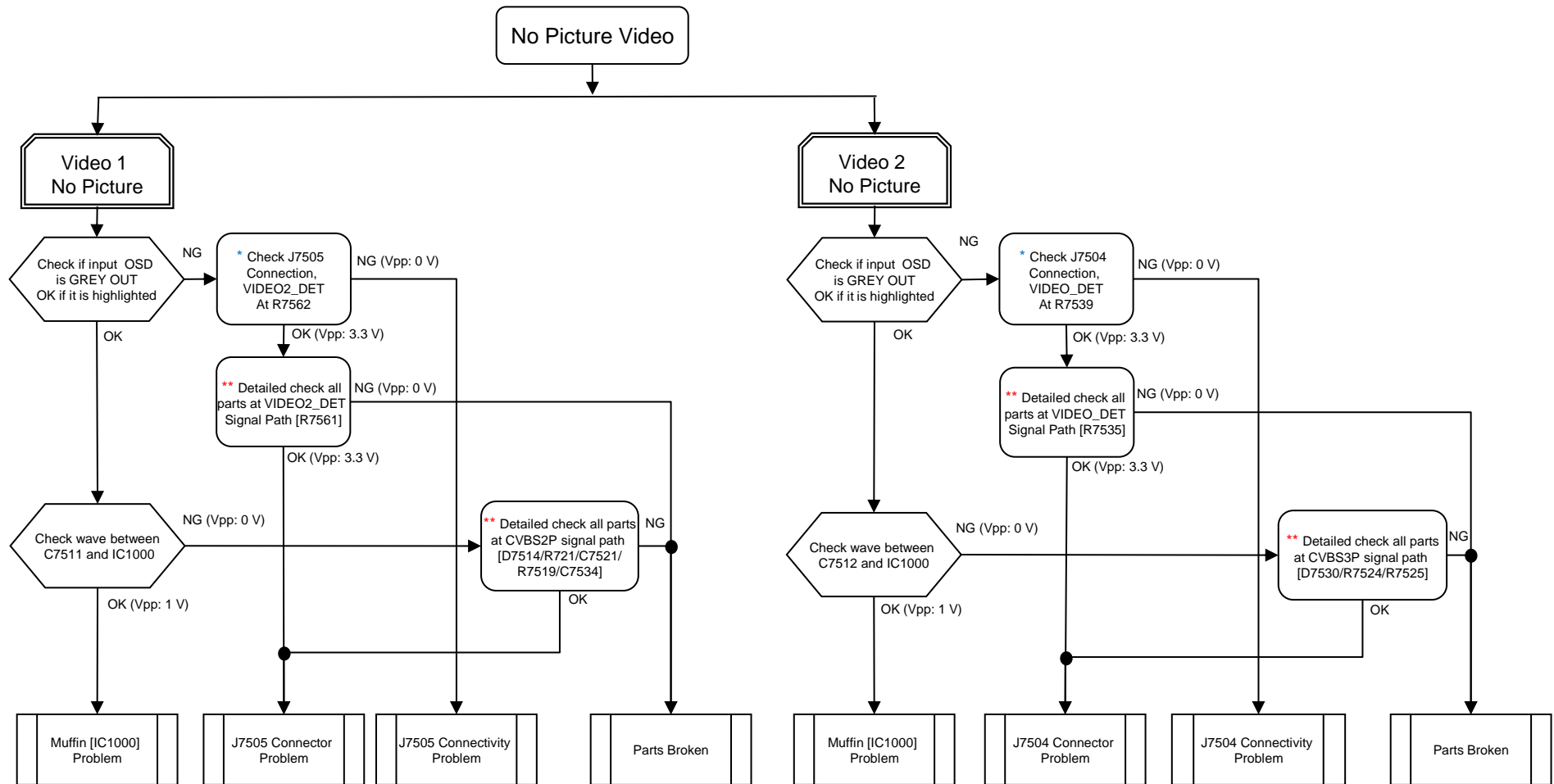

* → OK Condition : No solder splash can be seen
 → NG Condition : Solder splash can be seen

** → OK Condition : No part short-circuited
 → NG Condition : Part short-circuited

[All voltage measurement using Oscilloscope]

3-5-5. No Picture J/UC/HK/TW Destination (BMFL/BMFW)

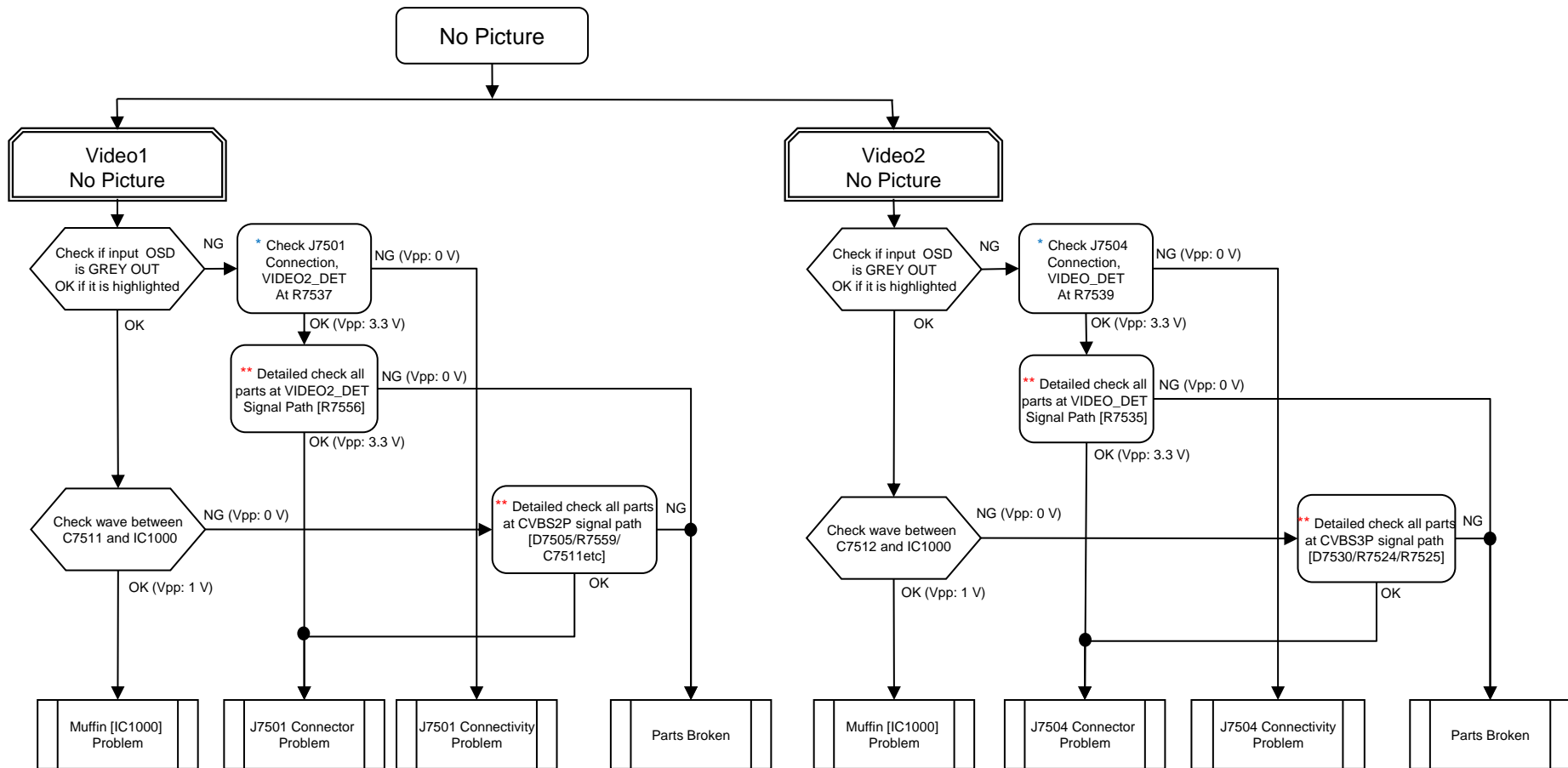

[All voltage measurement using Oscilloscope]

* → OK Condition : No solder splash can be seen
 → NG Condition : Solder splash can be seen

** → OK Condition : No part short-circuited
 → NG Condition : Part short-circuited

3-5-6. No Picture J/UC/HK/TW Destination (BMFL/BMFW)

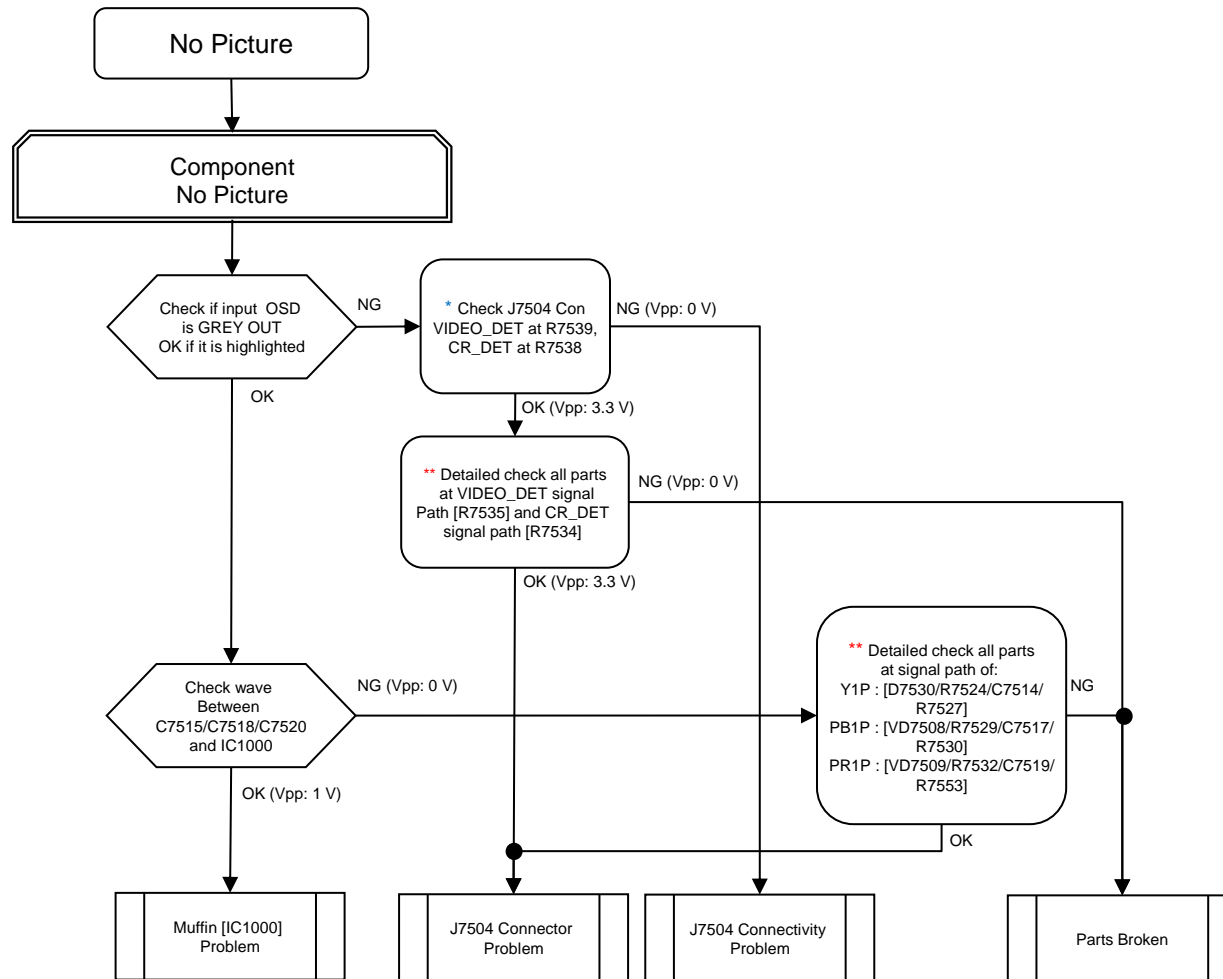

* → OK Condition : No solder splash can be seen
→ NG Condition : Solder splash can be seen

** → OK Condition : No part short-circuited
→ NG Condition : Part short-circuited

3-5-7. No Picture : @ Tuner

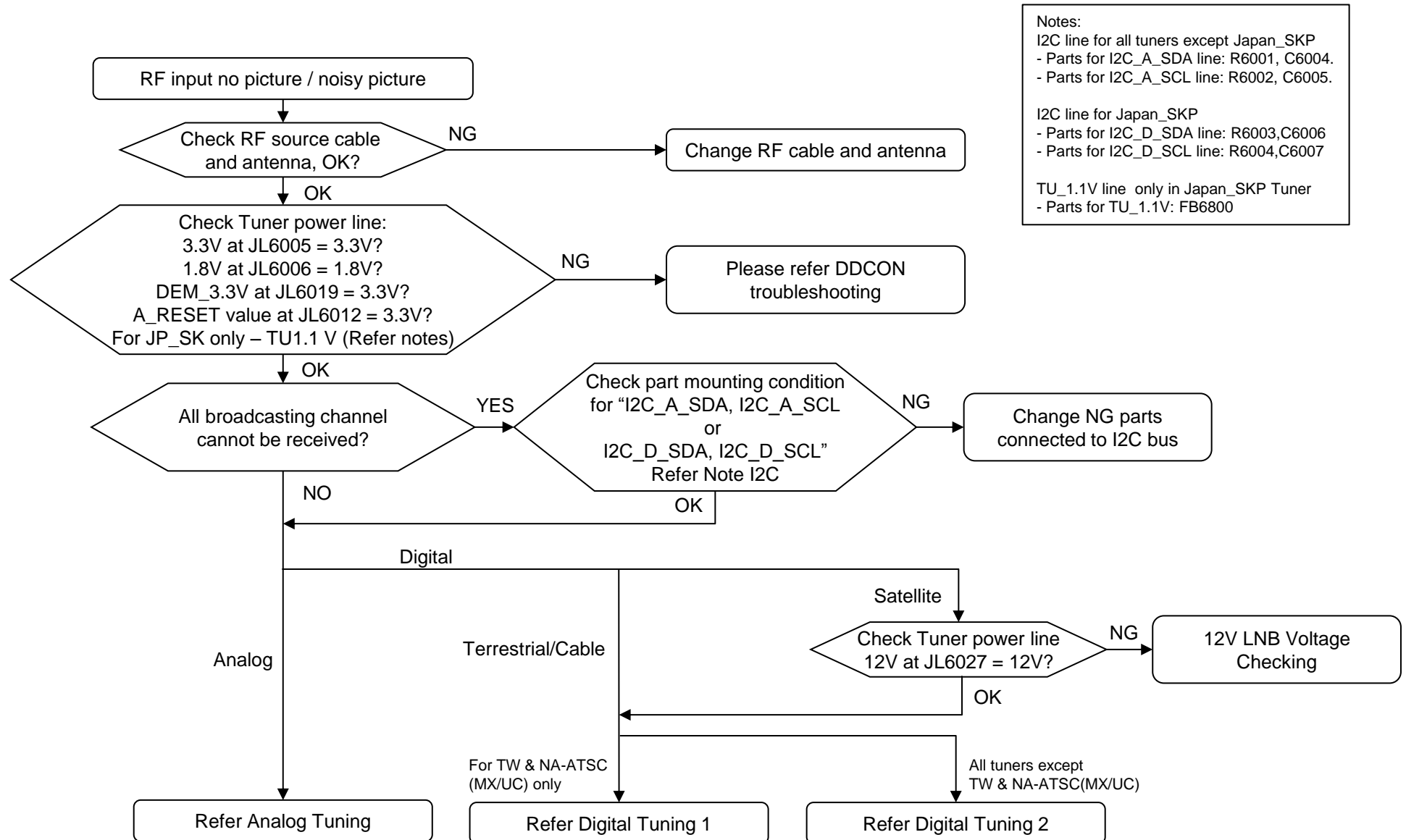

Notes:
 I2C line for all tuners except Japan_SKP
 - Parts for I2C_A_SDA line: R6001, C6004.
 - Parts for I2C_A_SCL line: R6002, C6005.

 I2C line for Japan_SKP
 - Parts for I2C_D_SDA line: R6003, C6006
 - Parts for I2C_D_SCL line: R6004, C6007

 TU_1.1V line only in Japan_SKP Tuner
 - Parts for TU_1.1V: FB6800

3-5-8. FOR 12V LNB Voltage Checking: @ AEP_W and JP_SKP

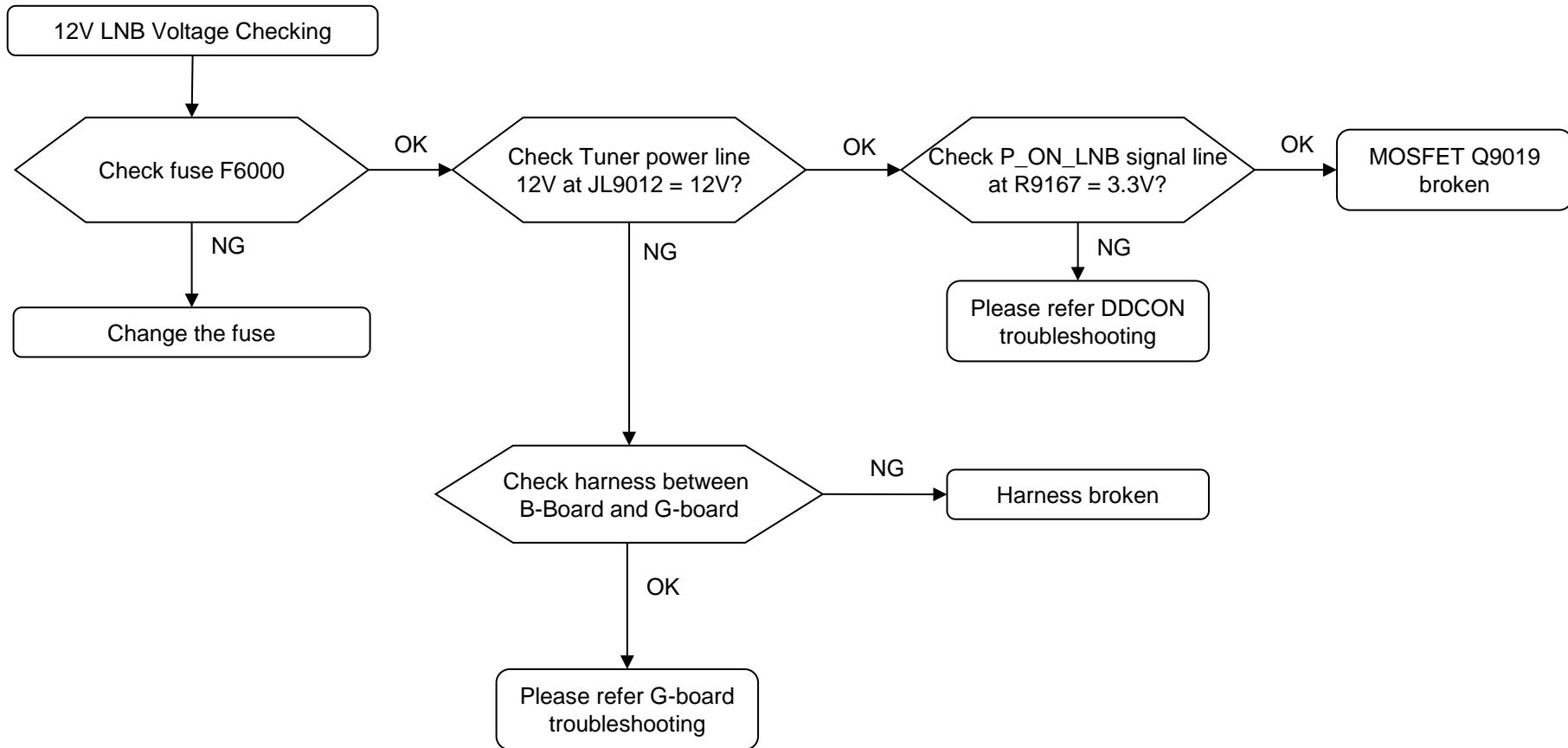

3-5-9. FOR ANALOG TUNING: @ All destination except JP

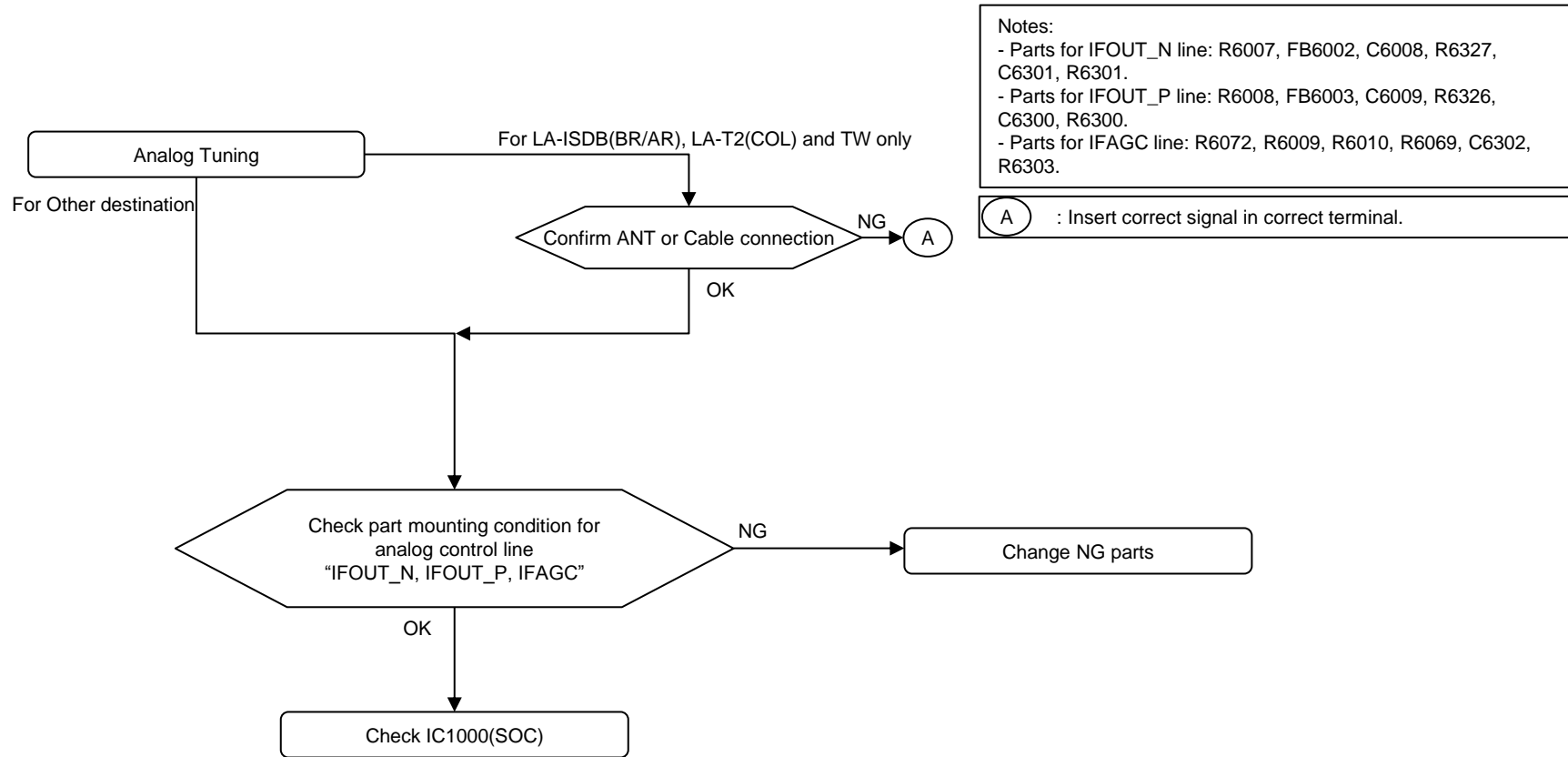

3-5-10. FOR DIGITAL TUNING 1: @ TW, NA-ATSC(MX/UC), JP_SKP and LA-T2(COL)

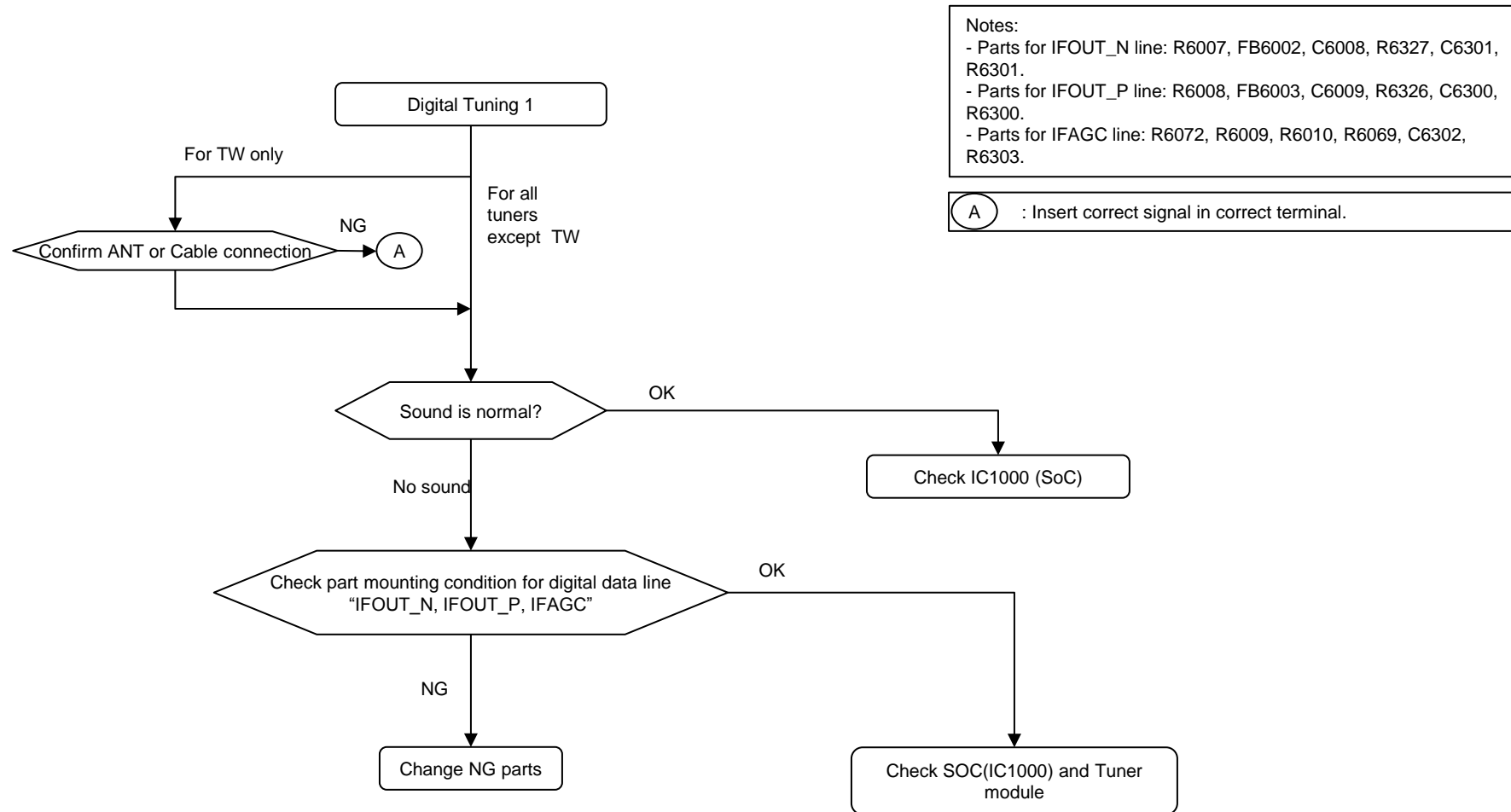

3-5-11. FOR DIGITAL TUNING 2: @ AEP_W, JP_SKP, PA_T2, CH/HK, LA-ISDB(BR/AR) and LA-T2(COL)

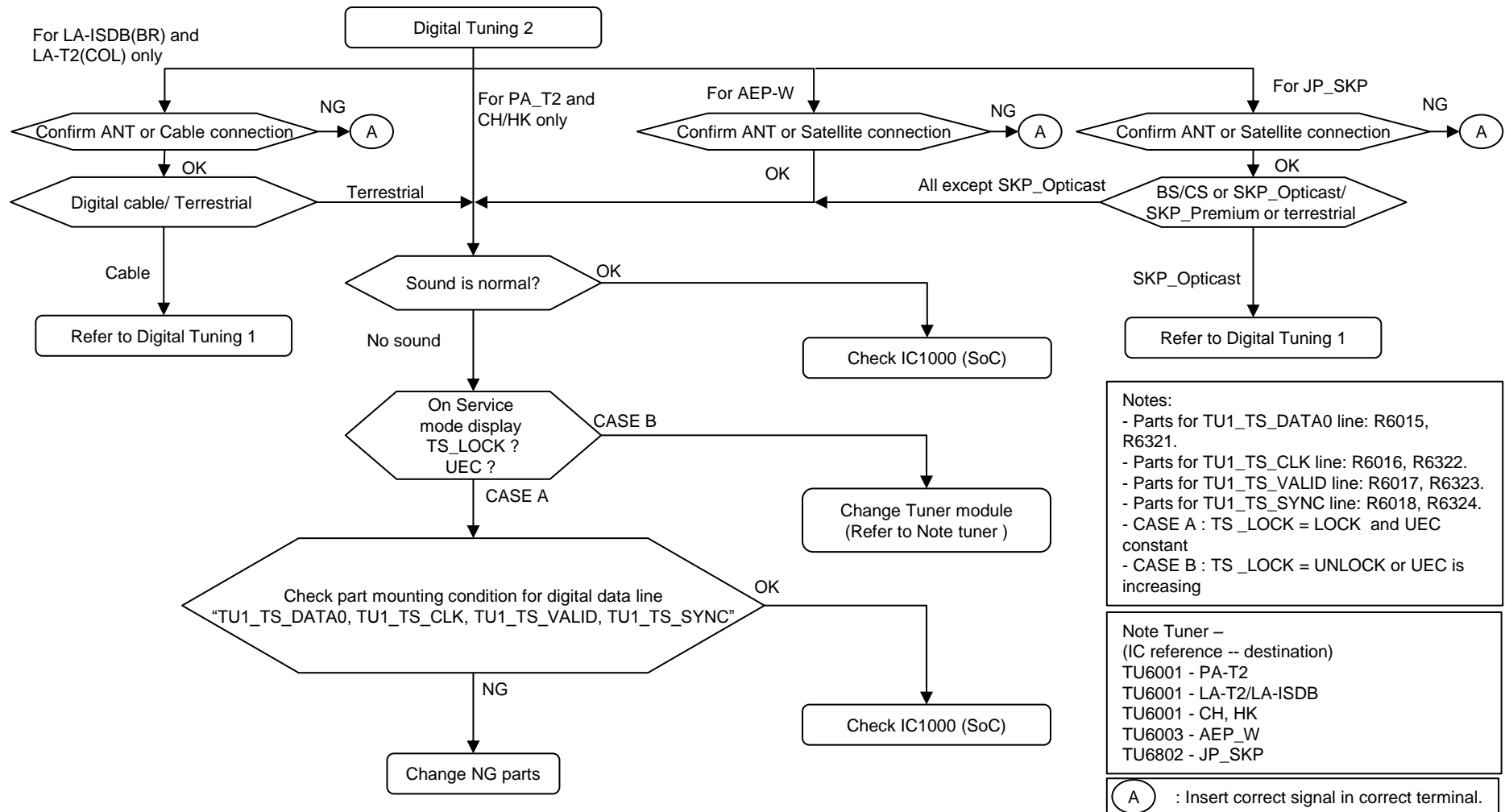

3-5-12. NO PICTURE: HDMI1

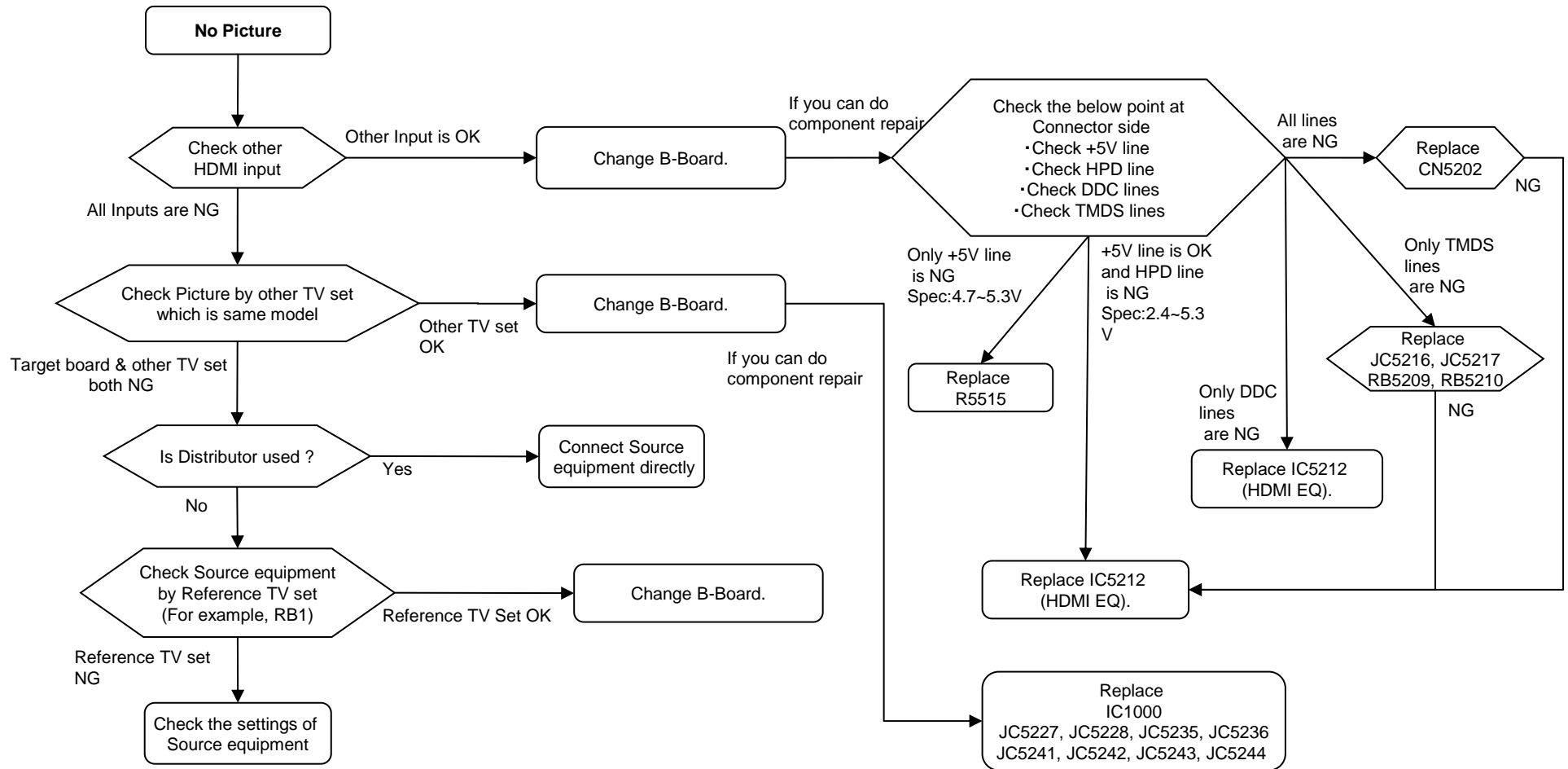

3-5-13. NO PICTURE: HDMI2

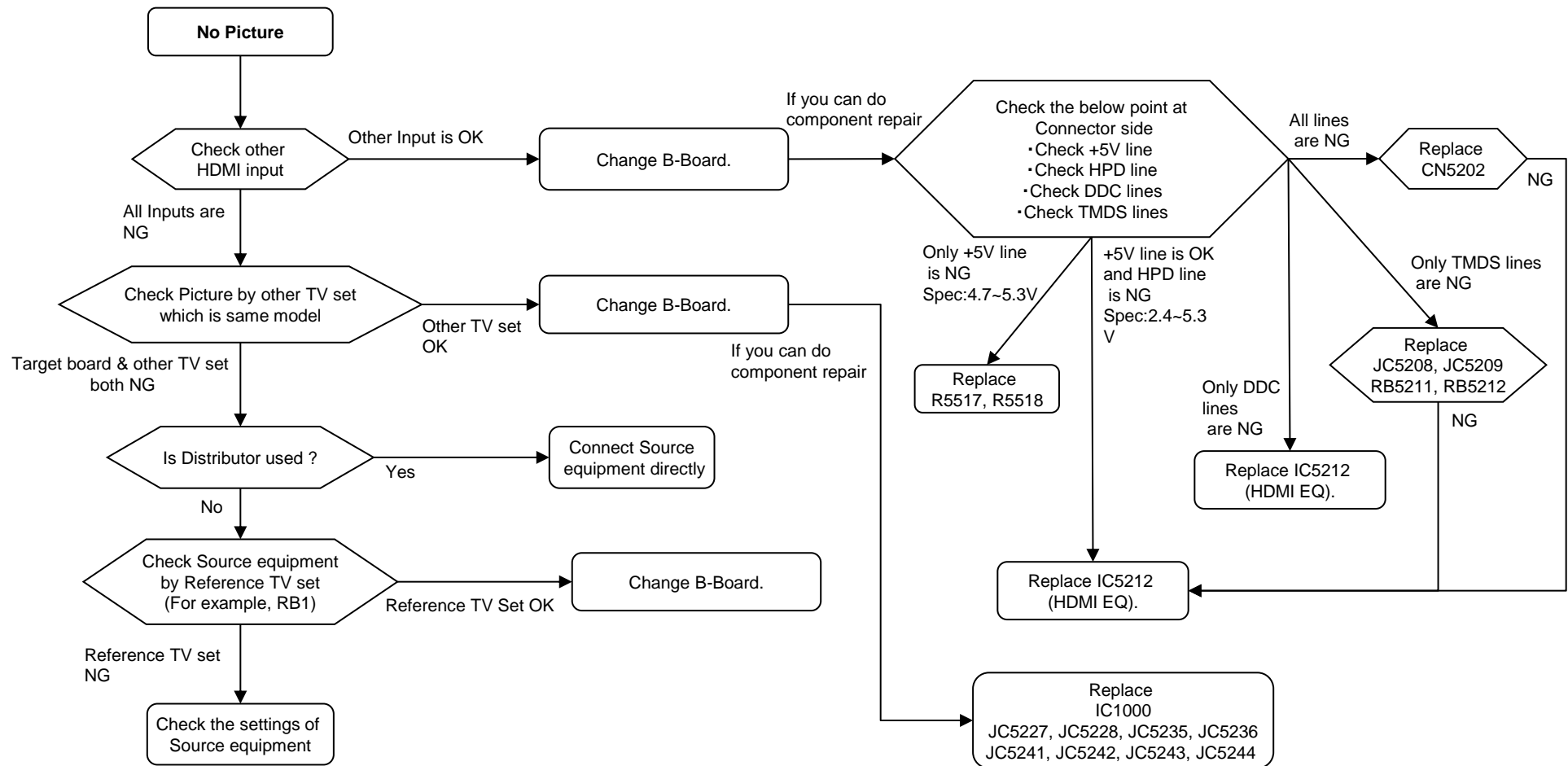

3-5-14. NO PICTURE: HDMI3

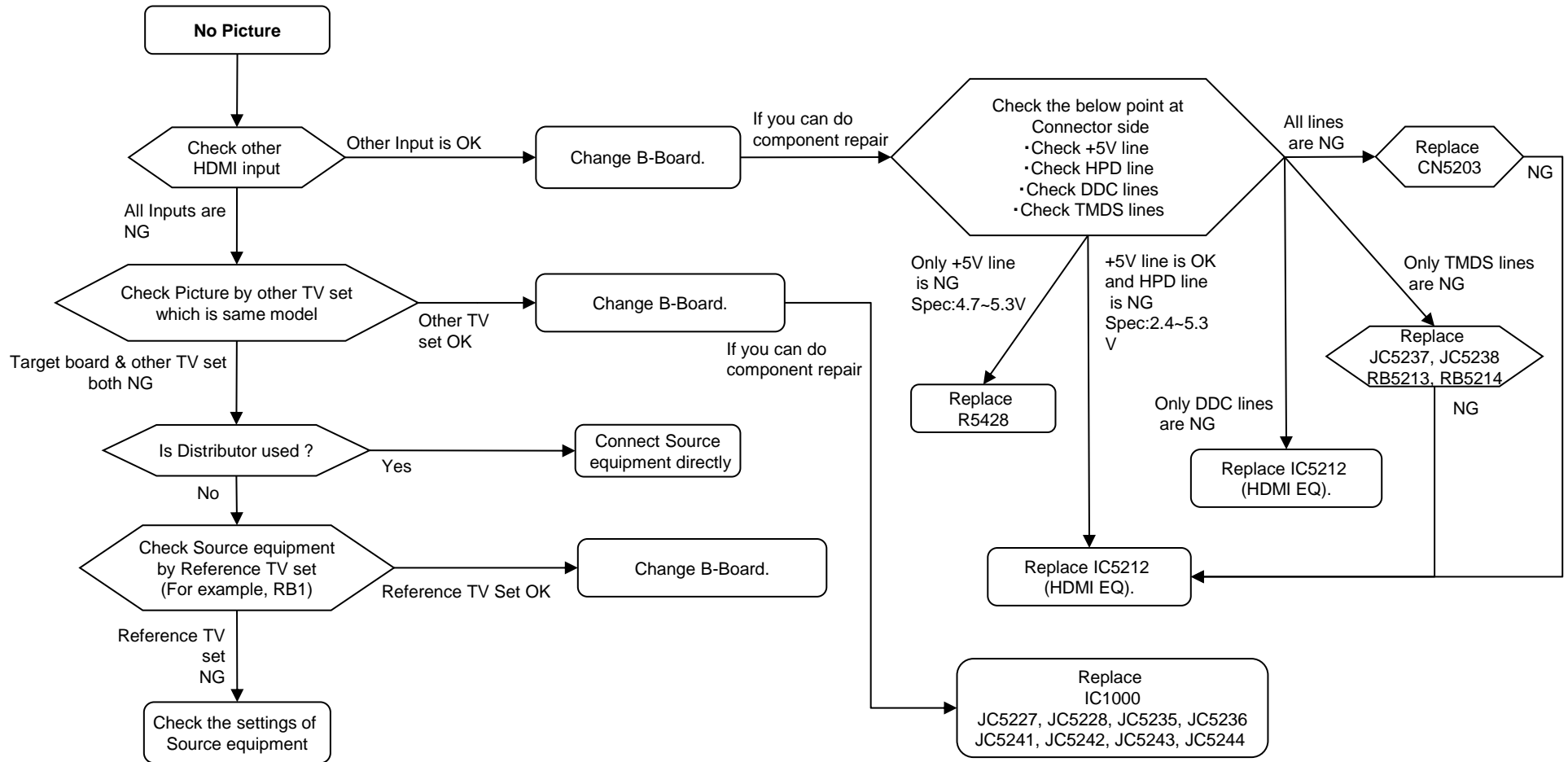

3-5-15. NO PICTURE: HDMI4

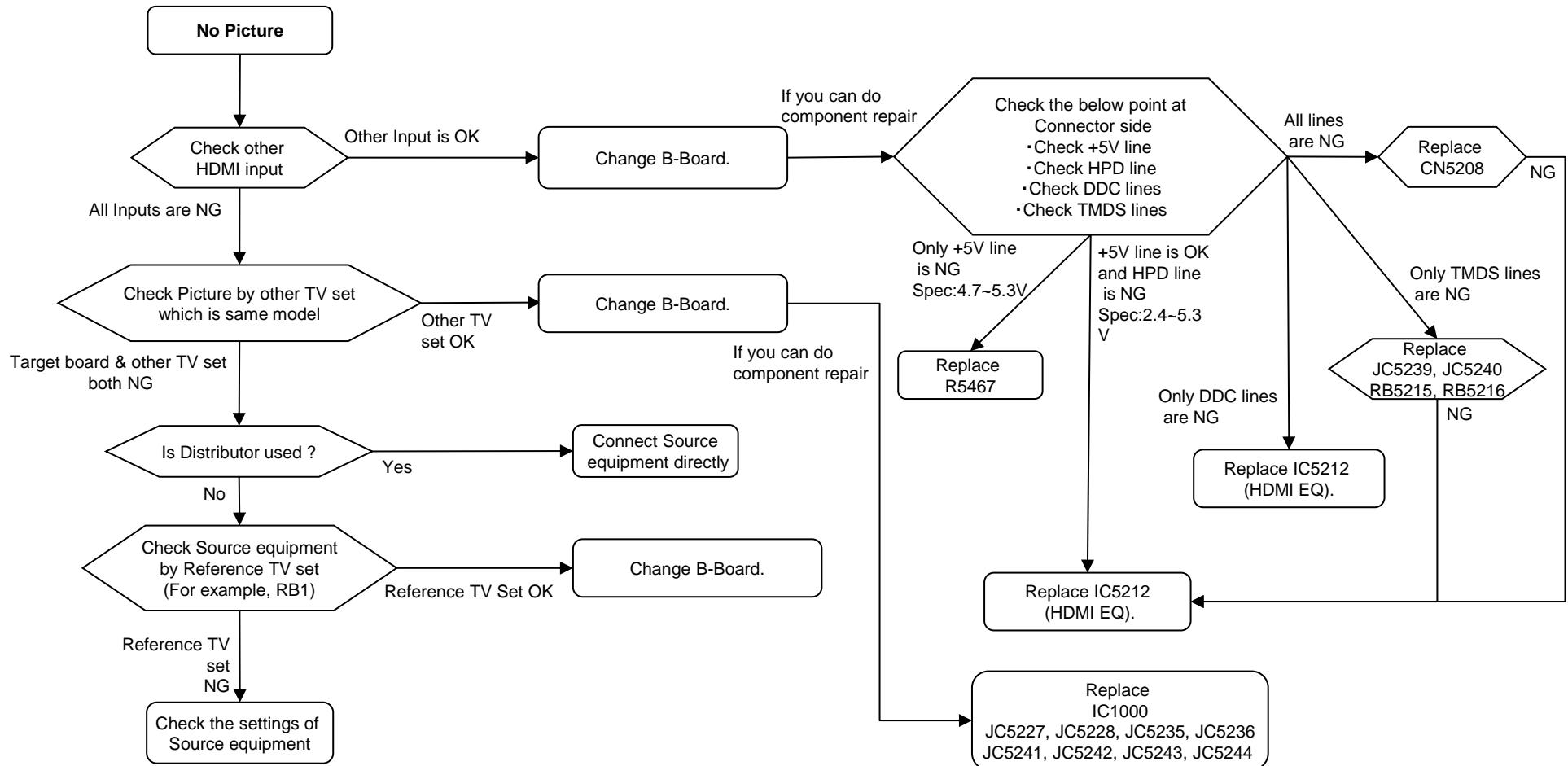

3-5-16. NO PICTURE: MHL (BMX)

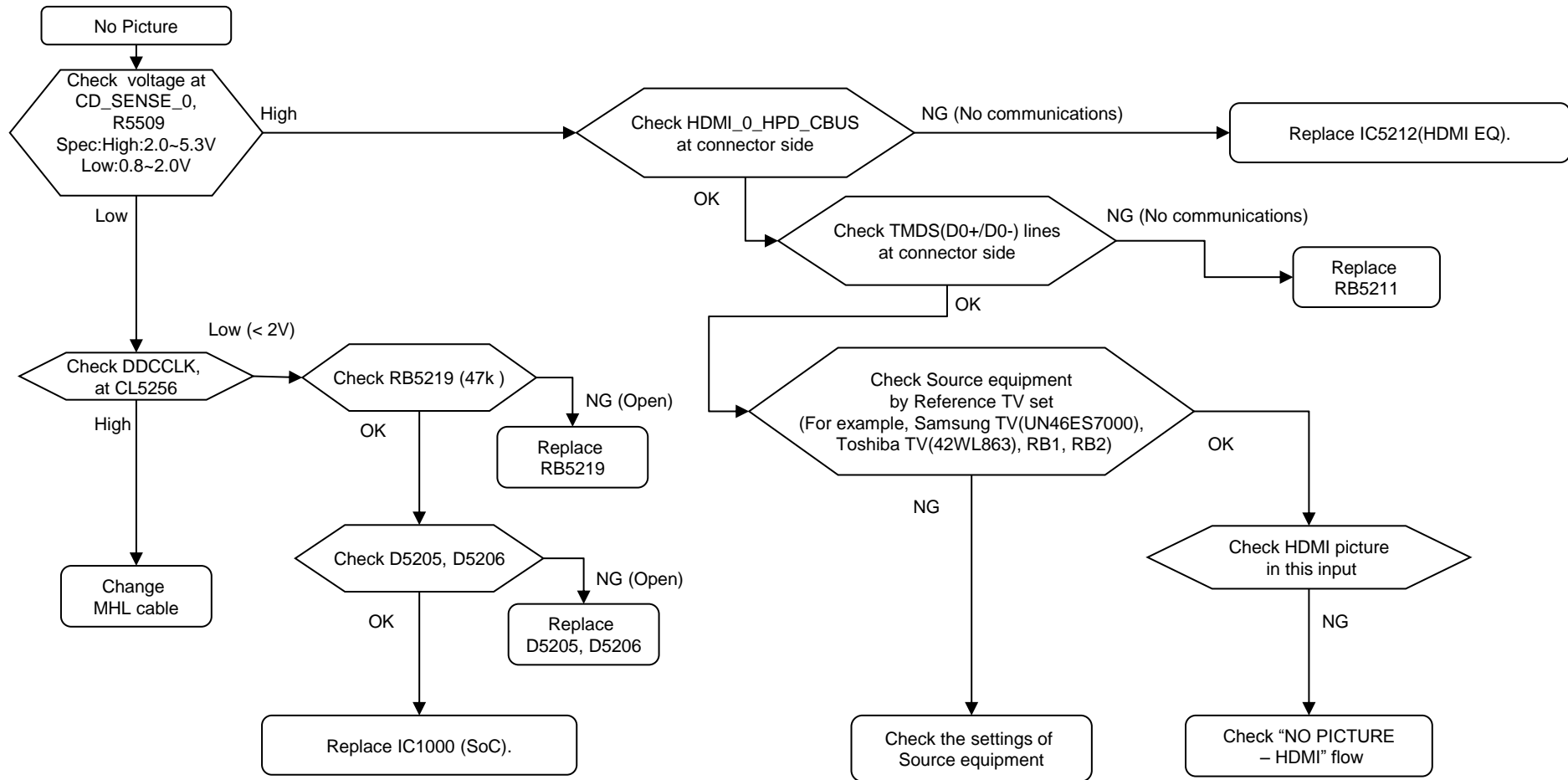

3-5-17. NO CHARGE: MHL (BMX)

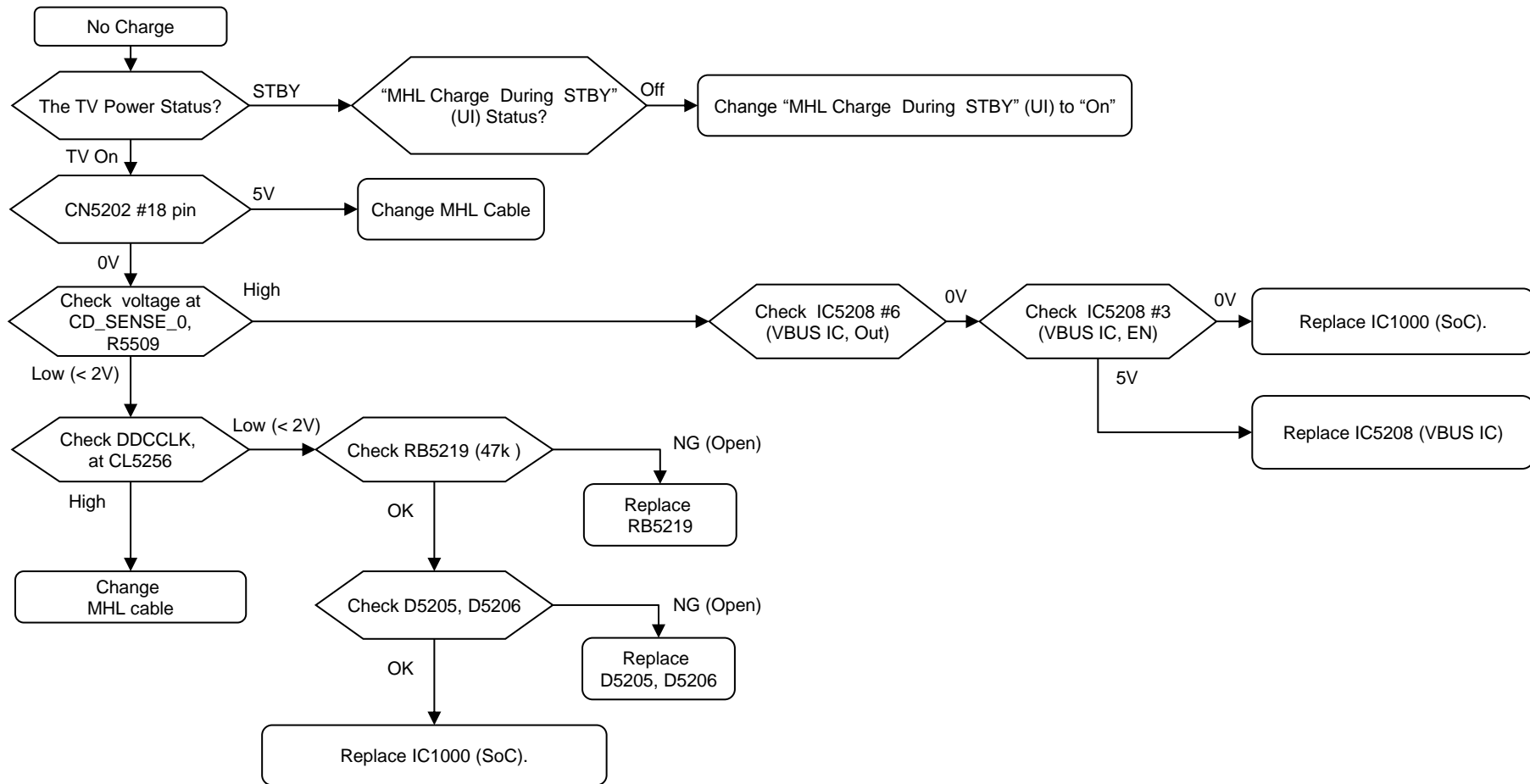

3-6. SIDE BUTTONS MALFUNCTION

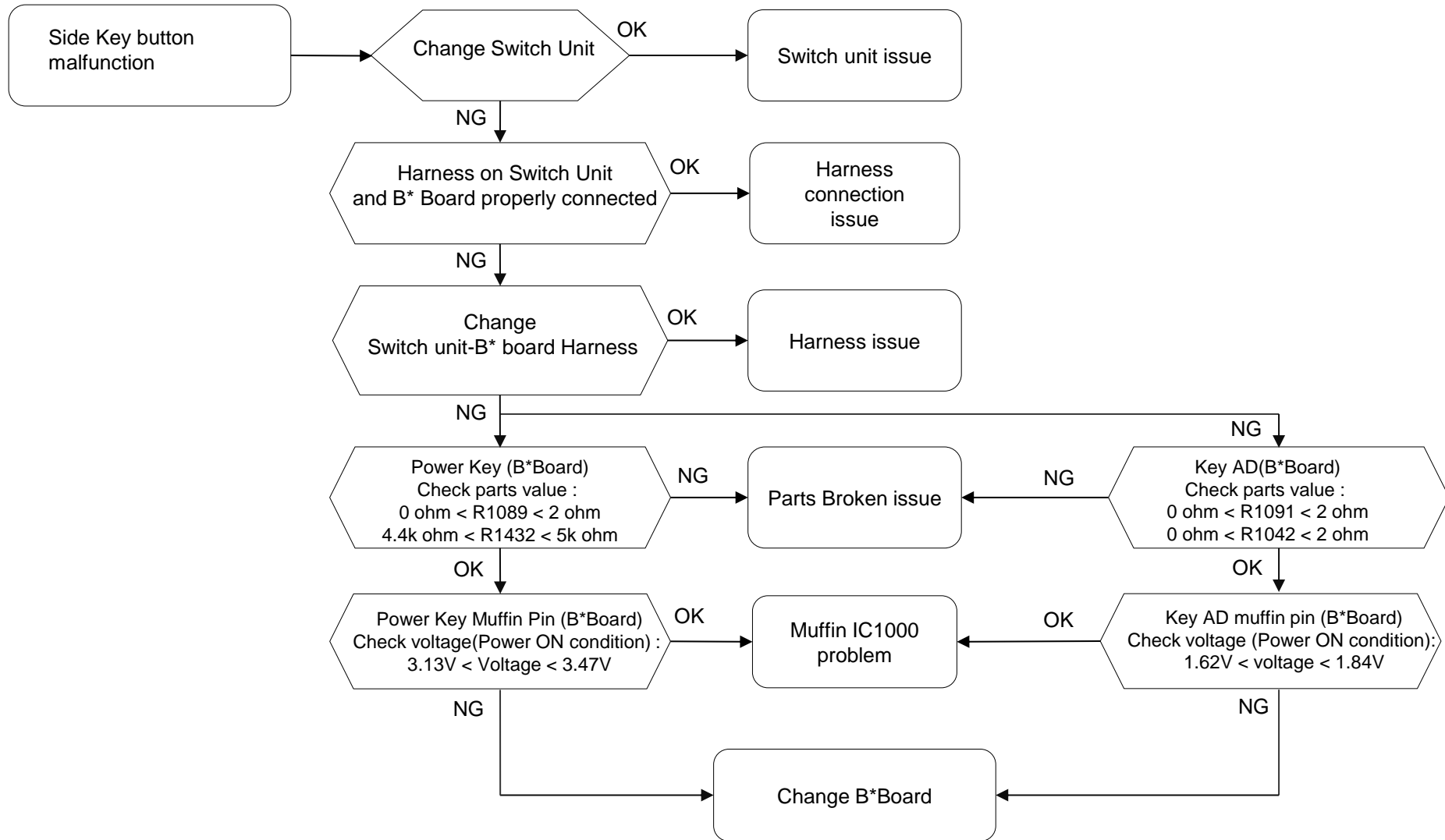

3-7. IR REMOTE COMMANDER MALFUNCTION

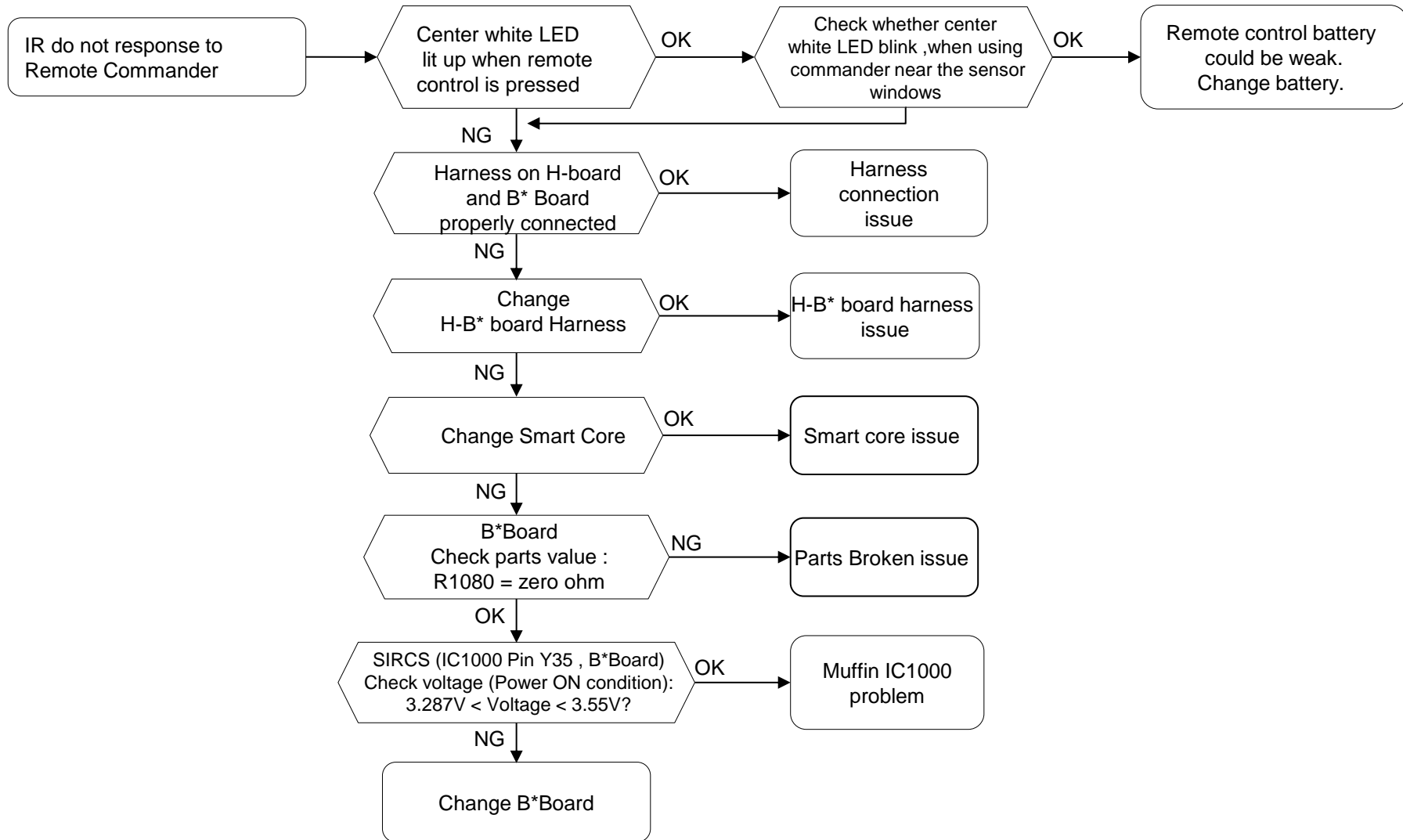

3-8. LIGHT SENSOR ERROR

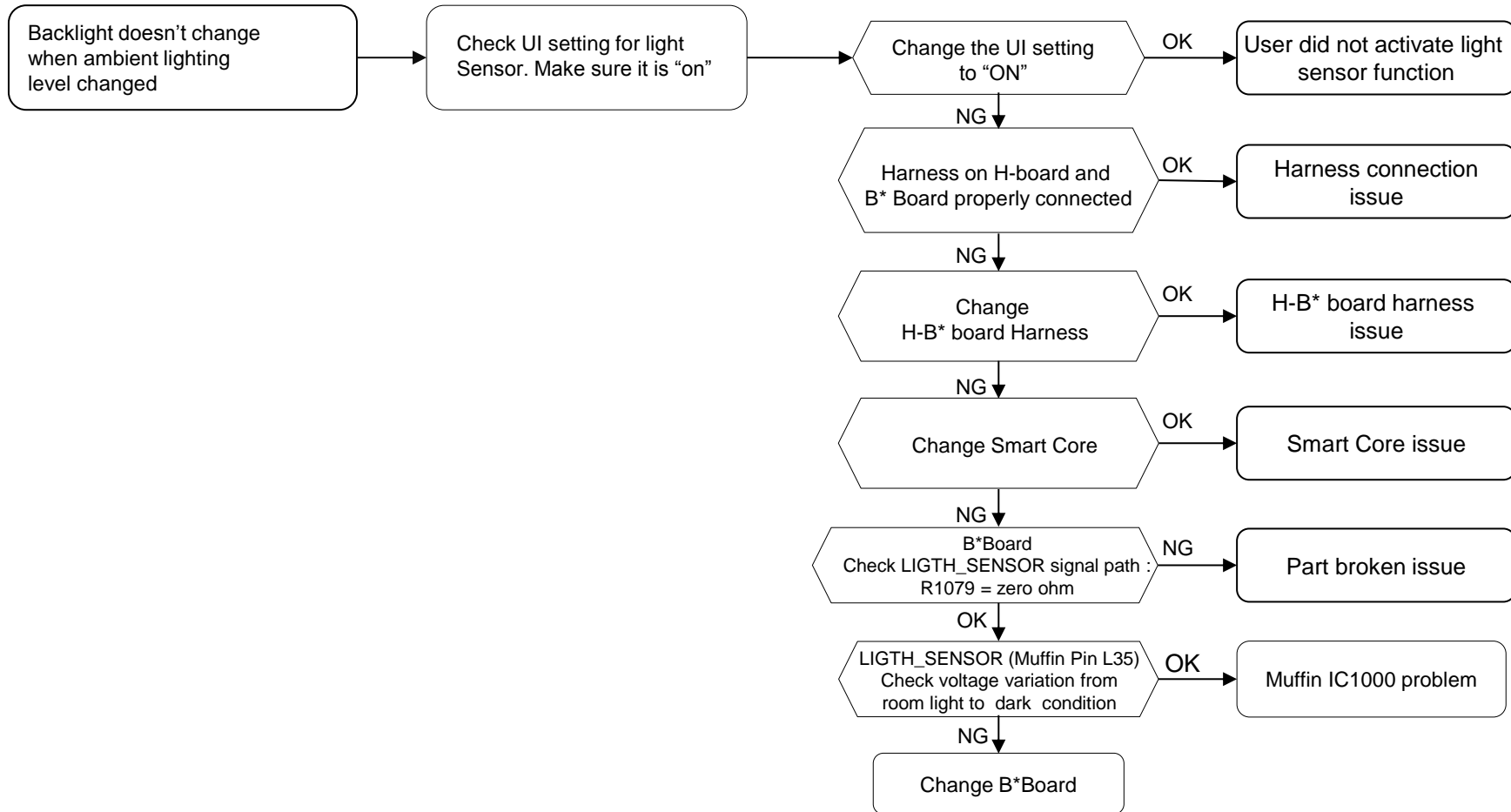

3-9. NETWORK MALFUNCTION

1) Ethernet (Wired)

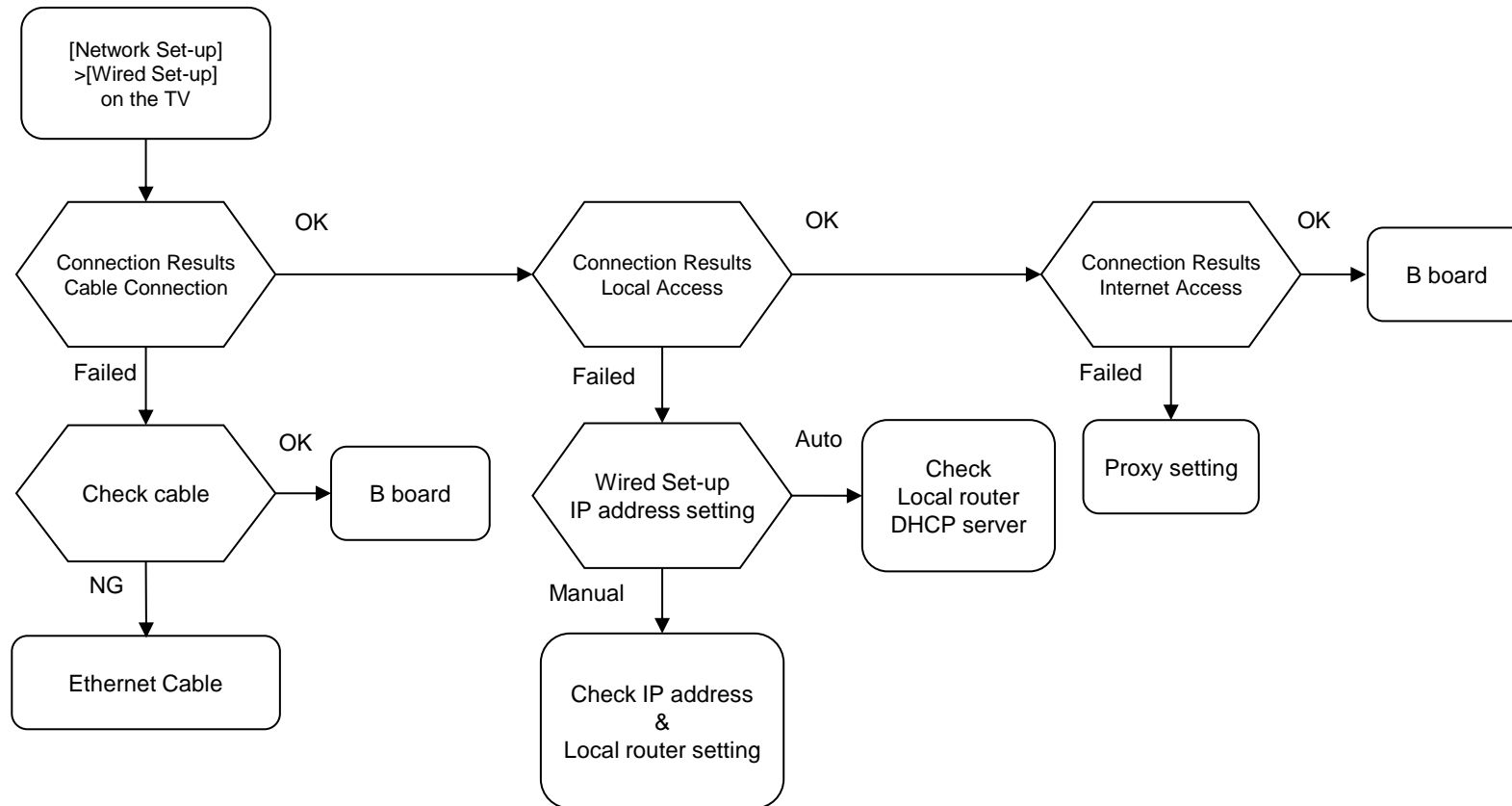

2) Internal Wireless Network malfunction

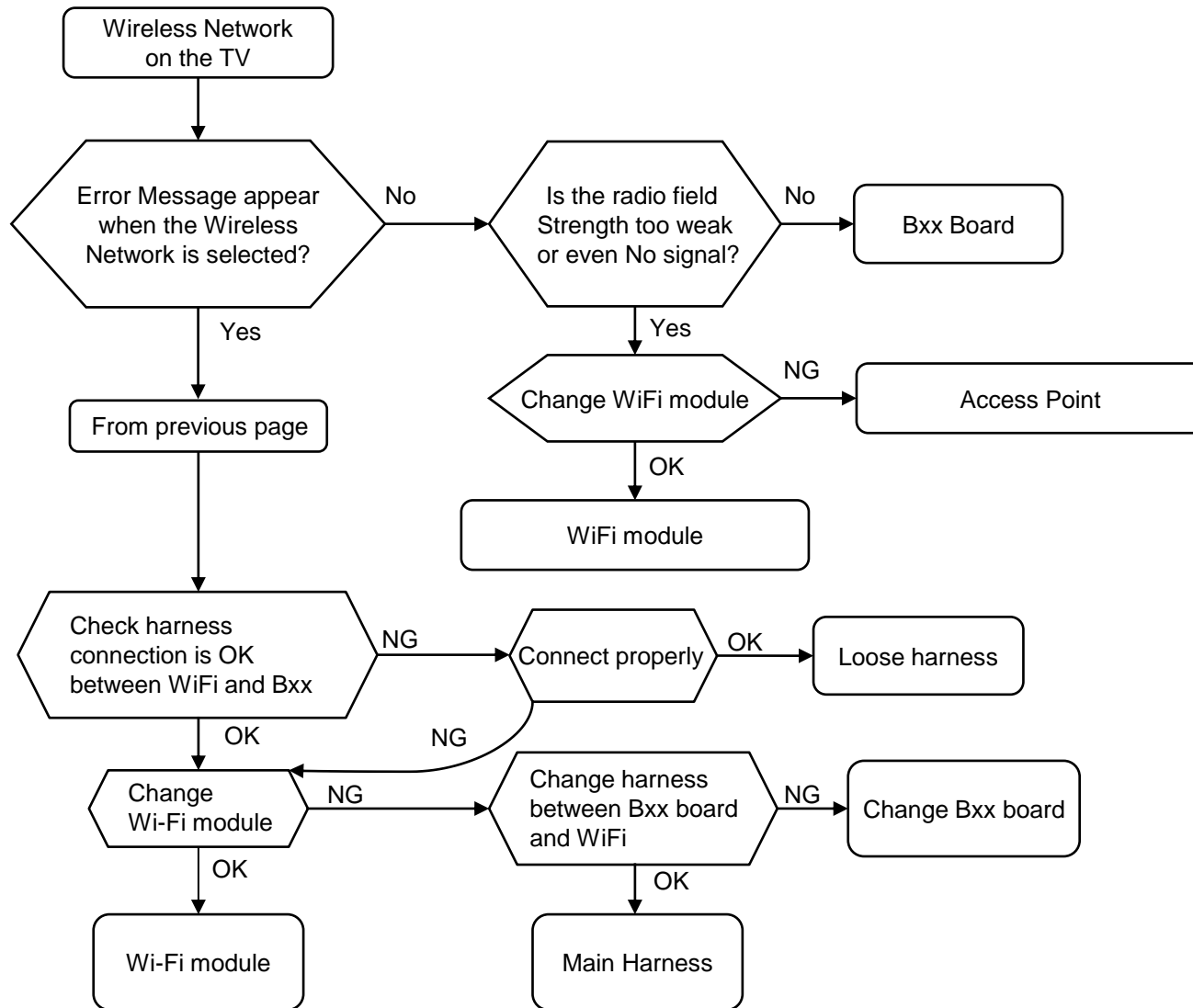

If Wi-Fi malfunction happens,

- Wi-Fi module
- Harness between WiFi and Bxx
- Bxx board

are suspected.

SEC 4. DIAGRAMS

4-1. BLOCK DIAGRAM

4-1-1. UC

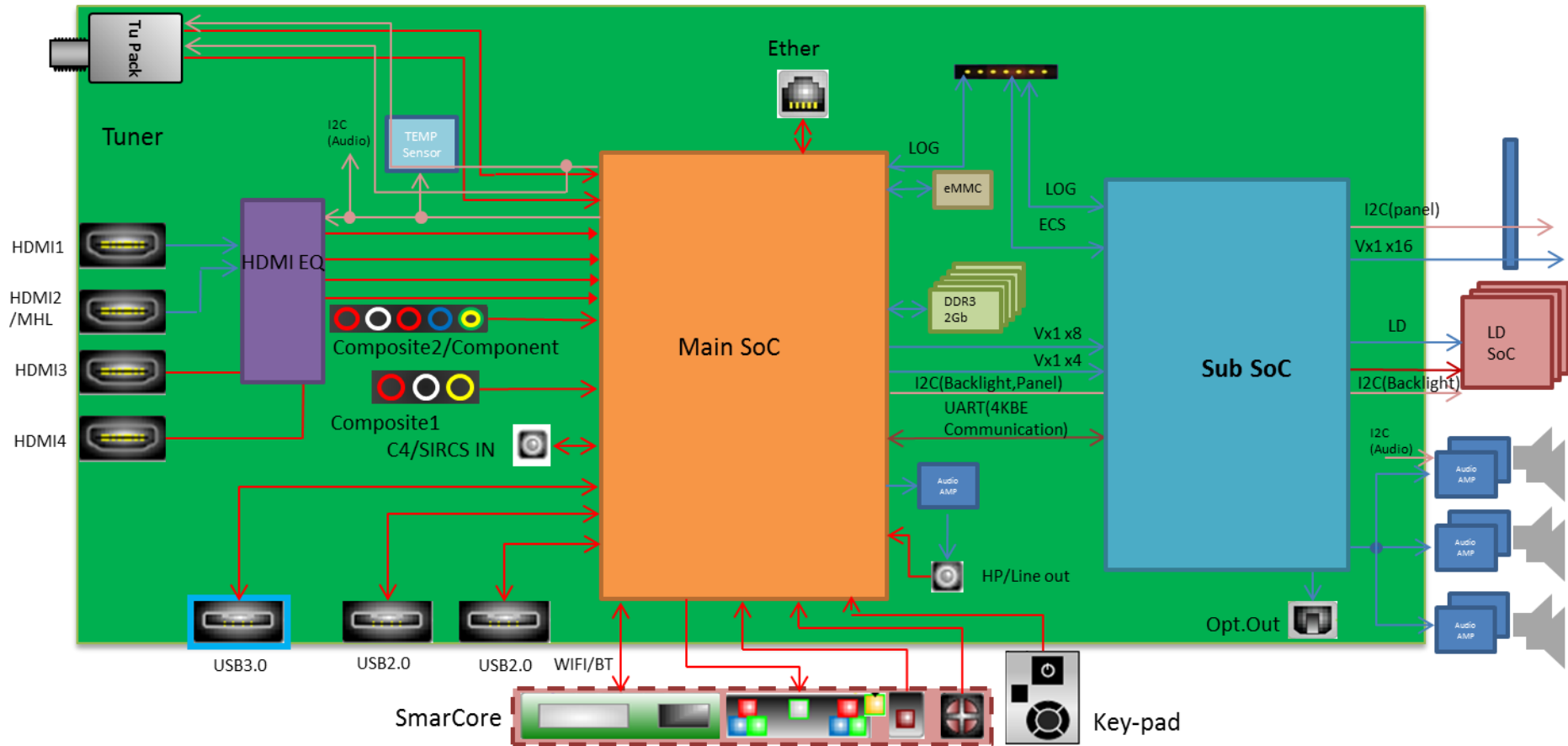

4-1-2. LA(BR/AR)

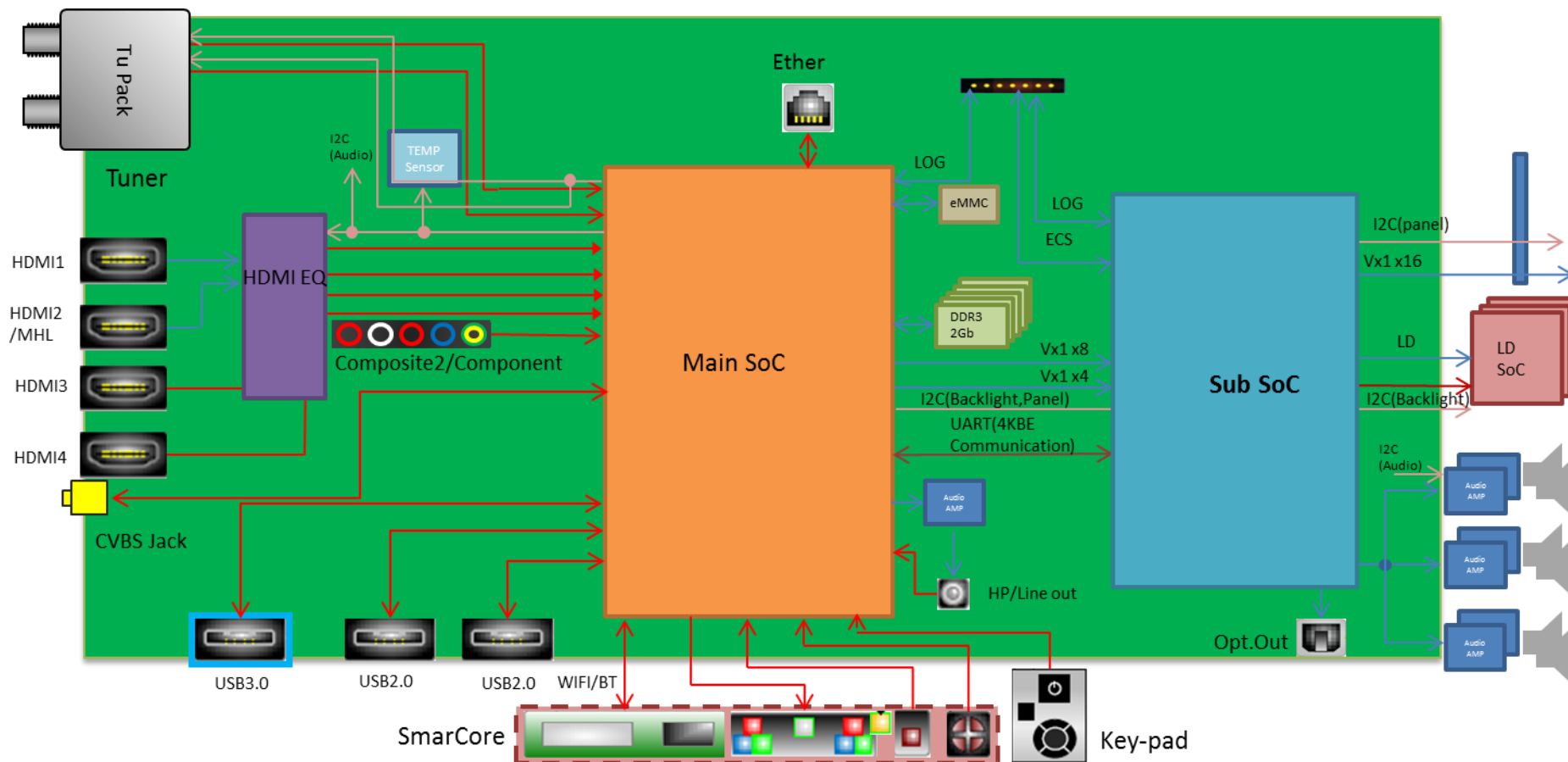

4-1-3. LA(COL)

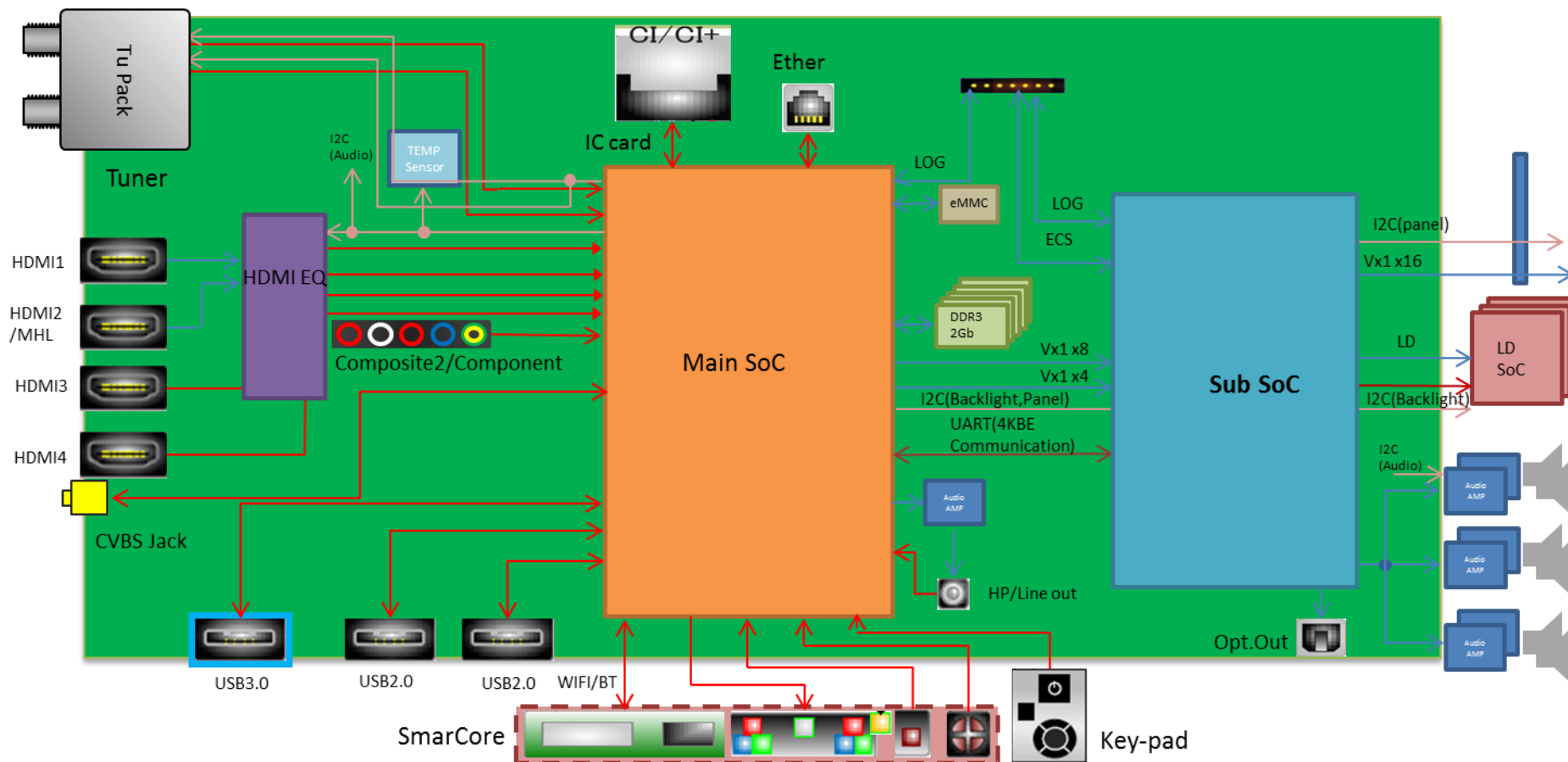

XBR-65X850C/855C/857C

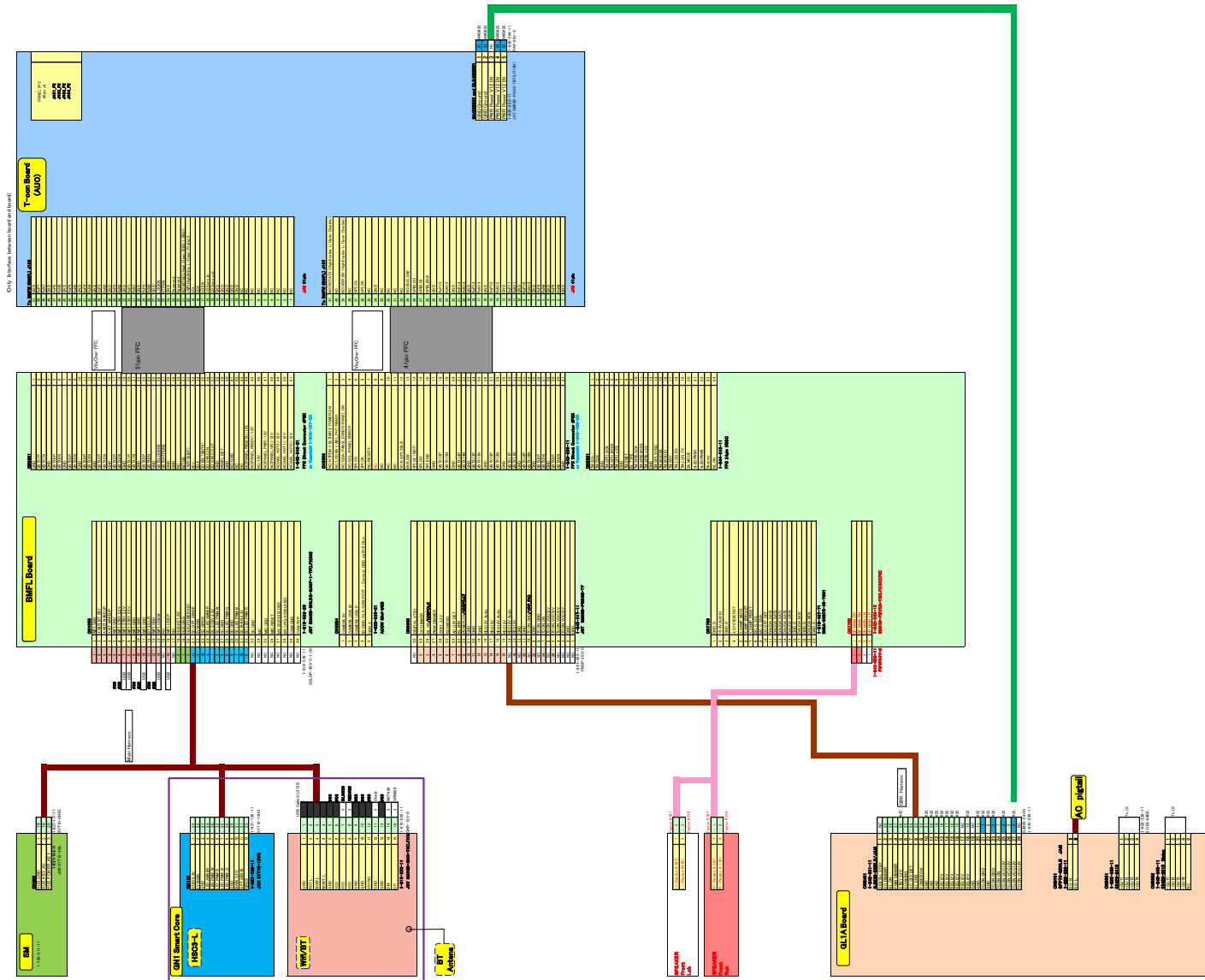

XBR-75X850C/855C

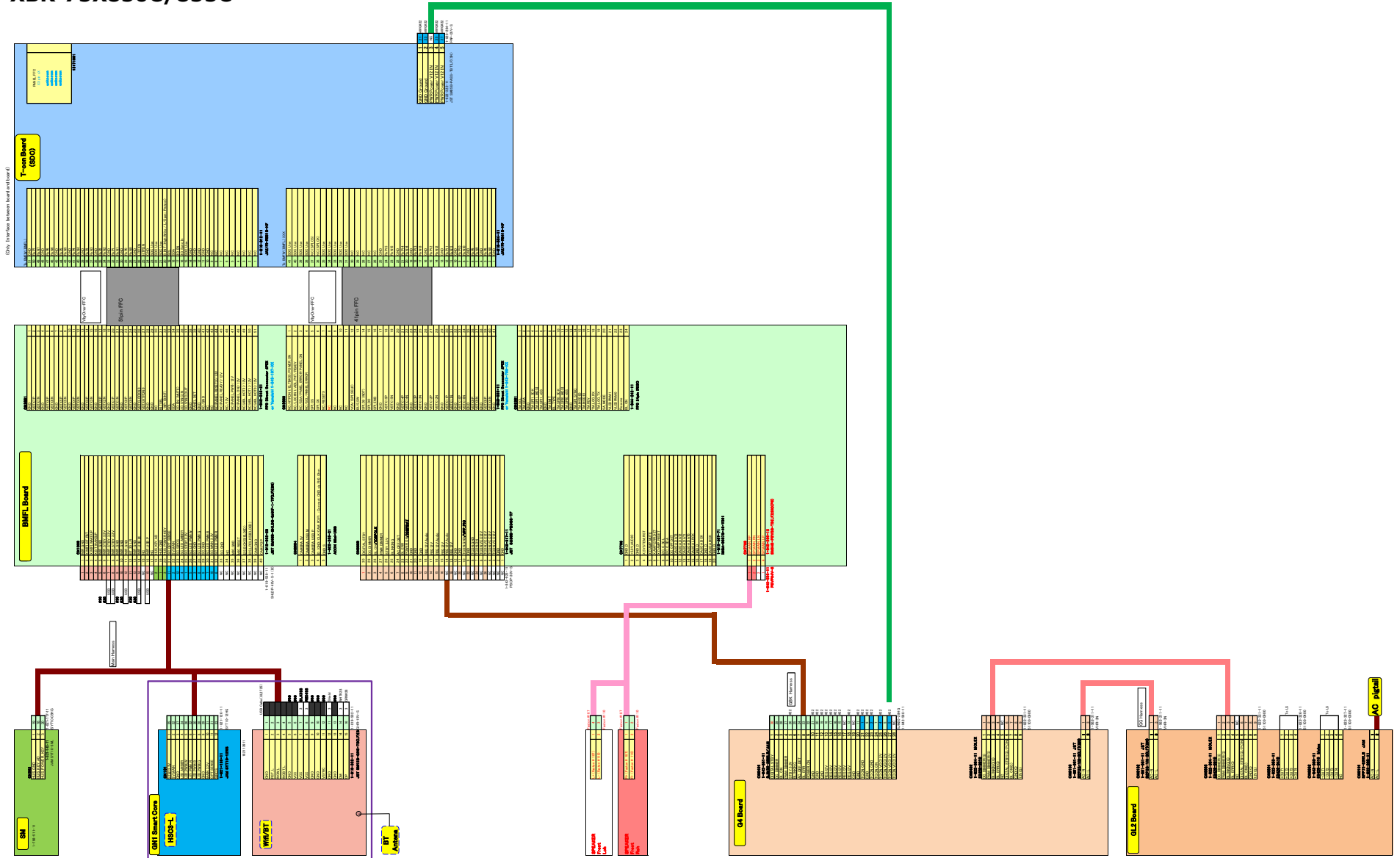

4-3. PC BOARD DIAGRAM

BMFL (A SIDE)

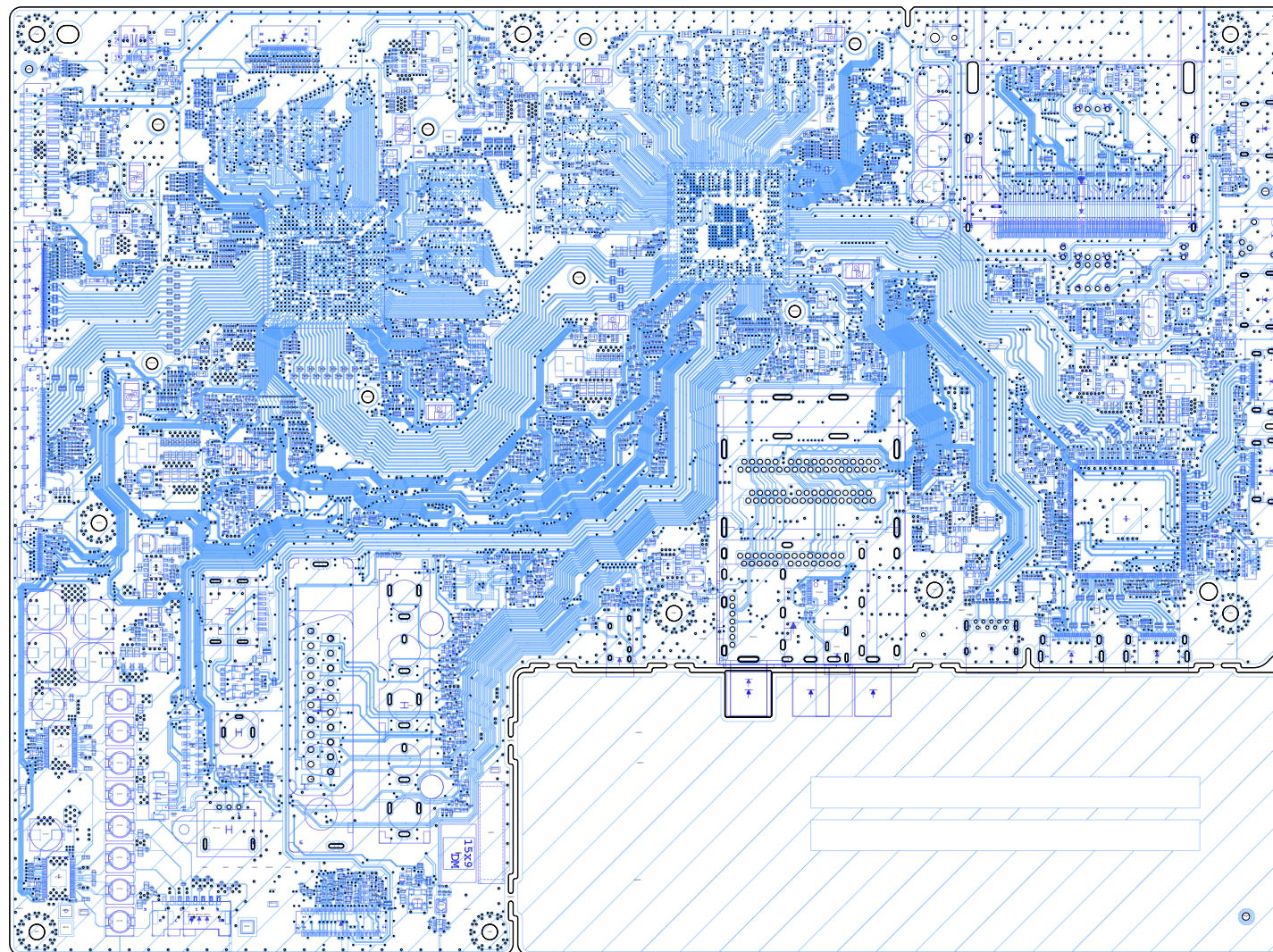

BMFL (B SIDE)

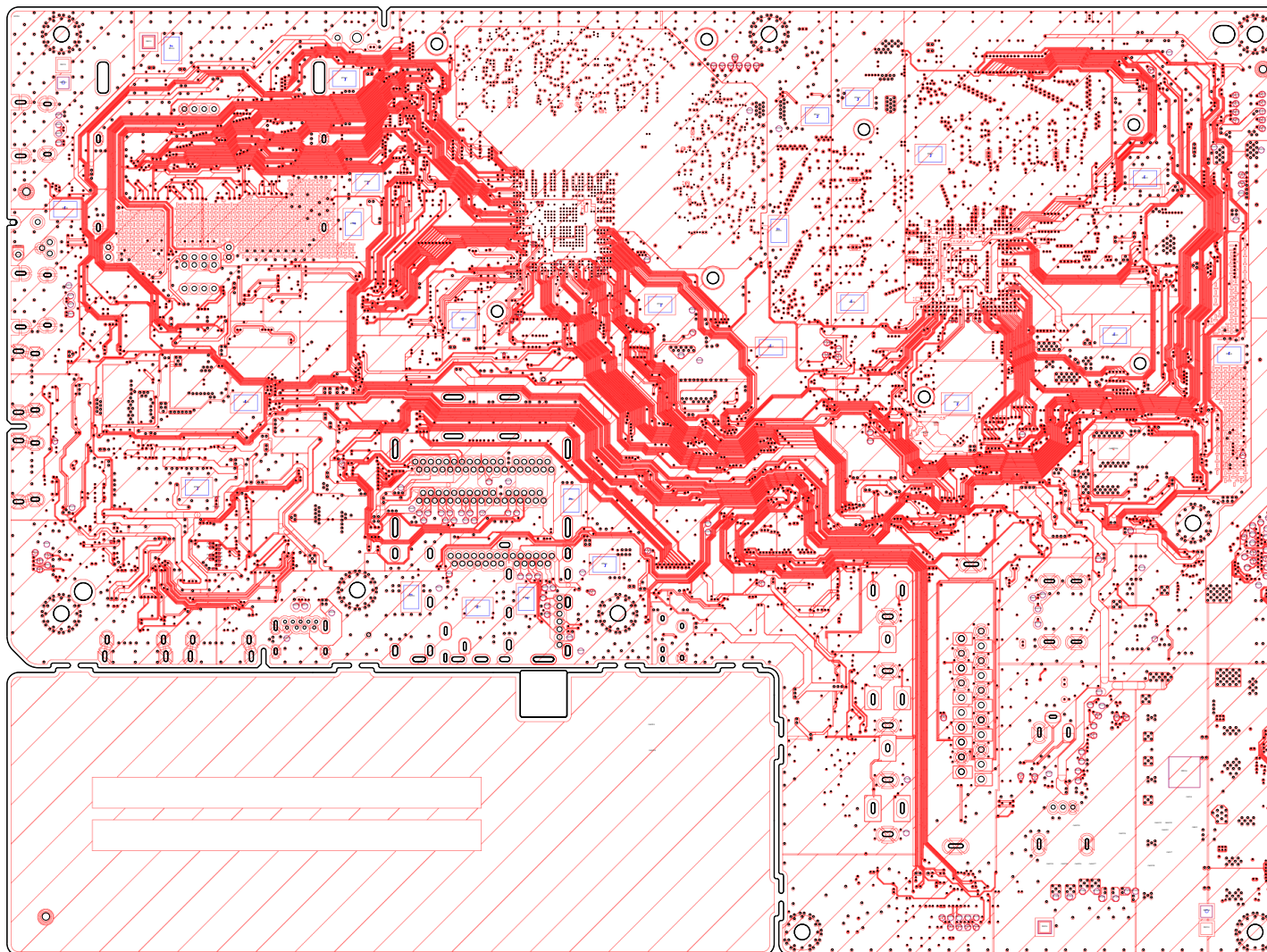

4-4. CIRCUIT BOARDS LOCATION

XBR-55X850C/855C/857C

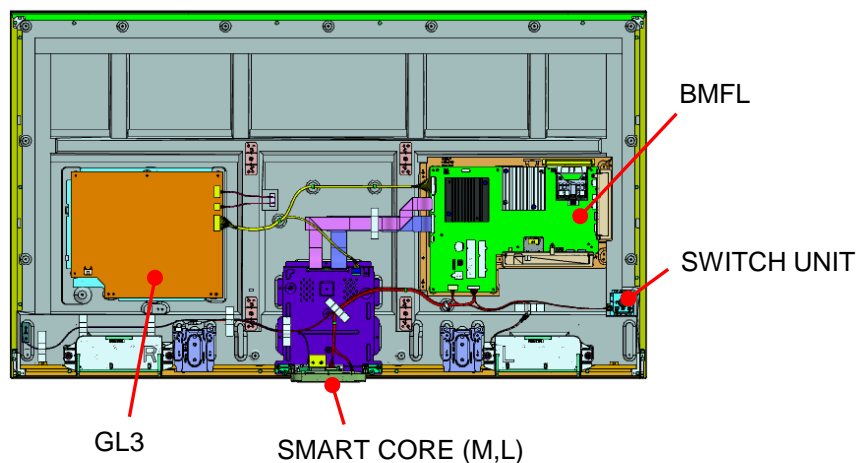

XBR-65X850C/855C/857C

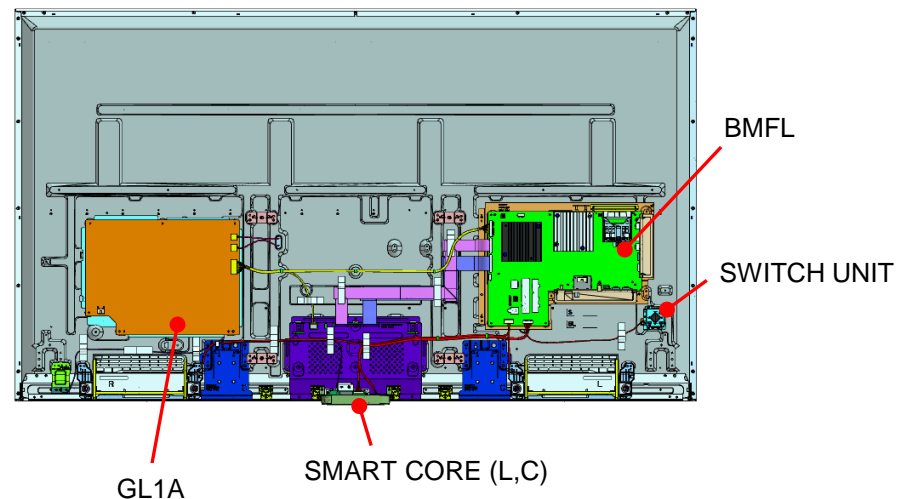

XBR-75X850C/855C

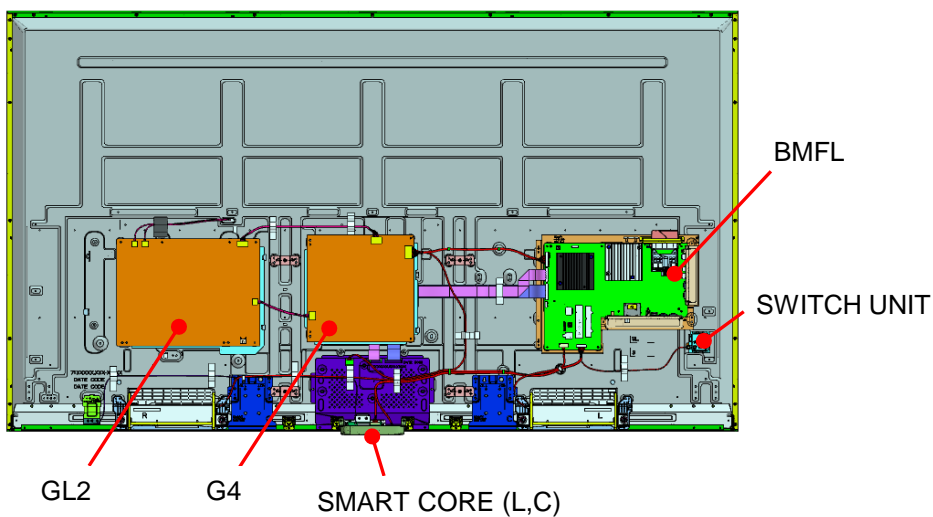

SMART CORE (L,C)

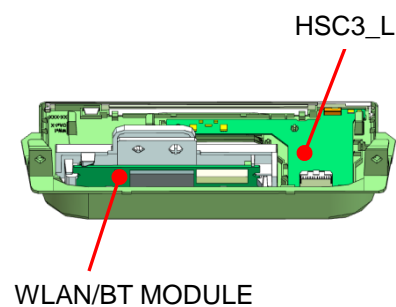

SMART CORE (M,L)

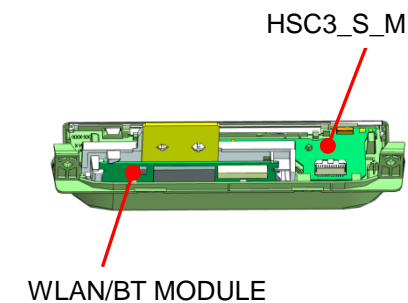

SEC 5. EXPLODED VIEWS

- Items with no part number and no description are not stocked because they are seldom required for routine service.
- The construction parts of an assembled part are indicated with a collation number in the remark column.
- Items marked " * " are not stocked since they are seldom required for routine service. Some delay should be anticipated when ordering these items.

The components identified by shading and mark \triangle are critical for safety. Replace only with part number specified.

The components identified by mark \square contain confidential information. Strictly follow the instructions whenever the components are repaired and/or replaced.

5-1. XBR-55X850C/855C/857C

5-1-1. REAR COVER

REF. No.	PART No.	DESCRIPTION	MARK
1	4-567-609-01	LABEL, CI	CO1
2	4-563-756-01	LABEL, SIDE TERMINAL (L)	
3	4-563-760-01	LABEL, UNDER TERMINAL	UC2
3	4-563-760-11	LABEL, UNDER TERMINAL	LA1
3	4-563-760-21	LABEL, UNDER TERMINAL	CR1/ECU/LA8/ CO1/BR6
4	4-563-764-01	LABEL, REAR TERMINAL	UC2
4	4-563-765-01	LABEL, REAR TERMINAL	except UC2
5	▲ 1-839-695-12	POWER-SUPPLY CORD (WITH CONN.)	CR1/ECU/LA8/BR6
5	▲ 1-839-696-12	POWER-SUPPLY CORD (WITH CONN.)	CO1/UC2/LA1
6	4-297-989-01	AC COVER	BR6
6	4-299-531-01	AC COVER	except BR
7	1-754-952-11	BT ANTENNA	except BR
7	1-754-954-11	BT ANTENNA	BR6
8	1-859-100-11	SPEAKER BOX ASSY (L)	
9	1-859-100-21	SPEAKER BOX ASSY (R)	
10	1-798-510-31	SWITCH UNIT (SM-G-WW)	except BR
10	1-798-510-41	SWITCH UNIT (SM-G-KIT)	BR6
11	4-559-710-01	REAR COVER (L HRN) A	CO1
11	4-559-710-11	REAR COVER (L HRN) A	CR1/ECU/LA8/ UC2/LA1
11	A-2073-677-A	REAR COVER (L HRN) A	BR6

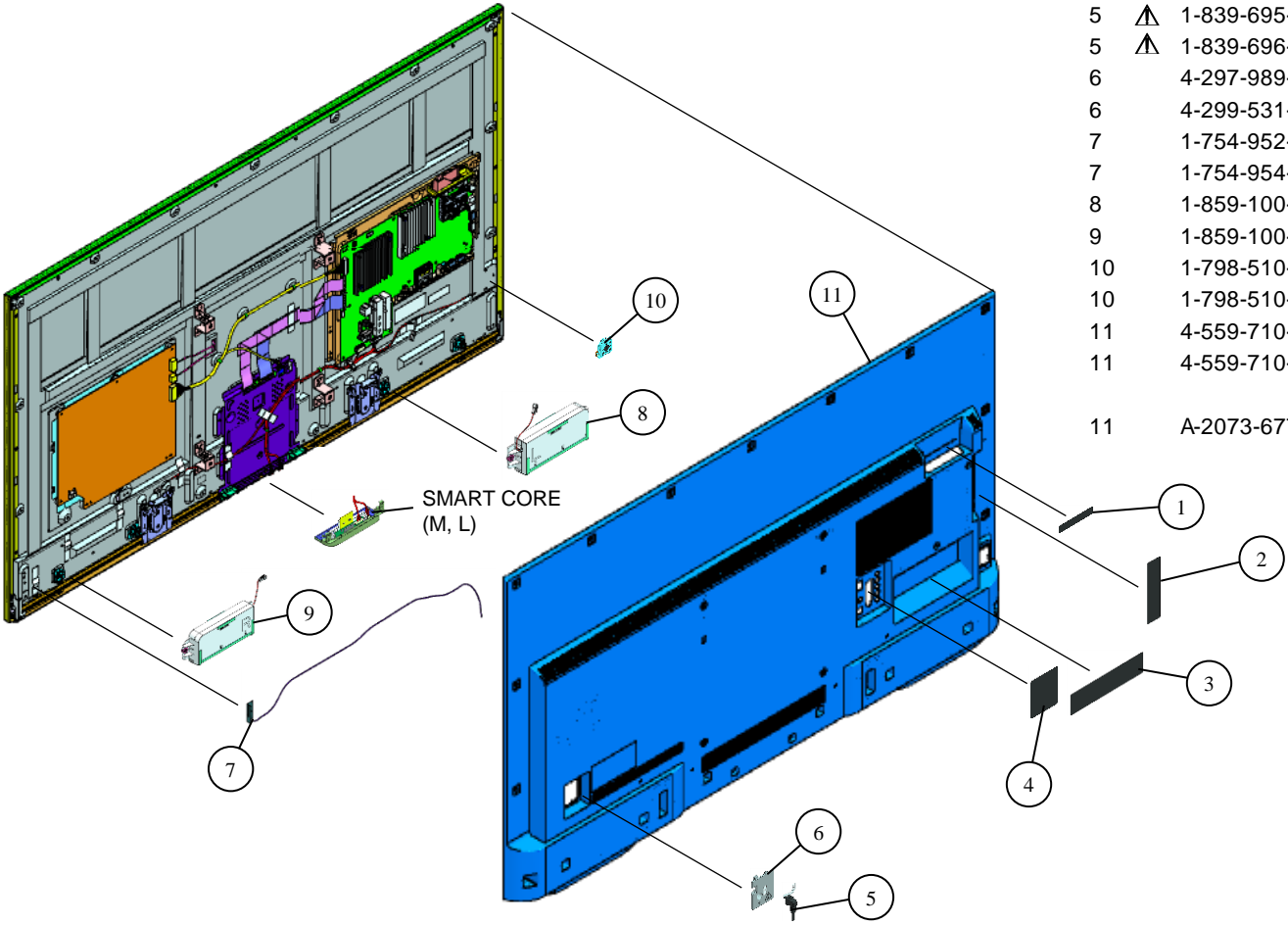

5-1-2. LCD PANEL

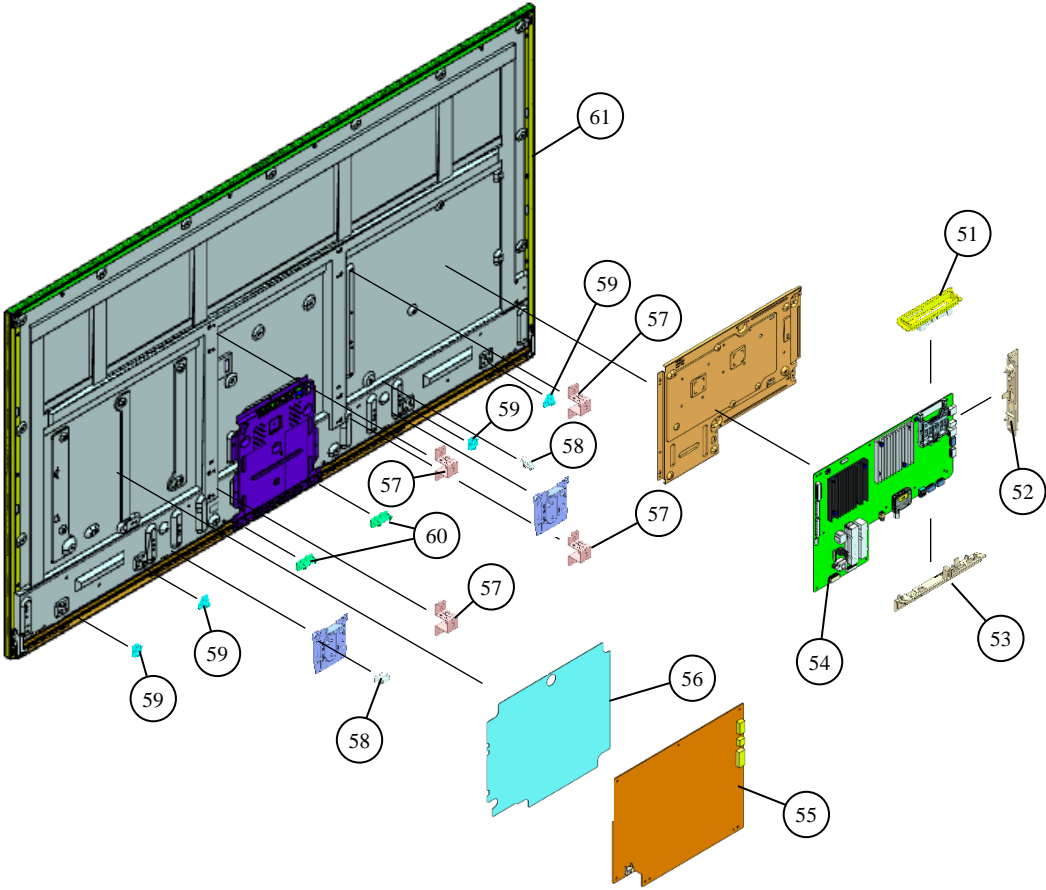

REF. No.	PART No.	DESCRIPTION	MARK
51	4-546-441-11	BRACKET, TOP FL (MOLD)	CO1
52	4-546-442-01	BRACKET, SIDE FL (MOLD)	except BR6
52	4-546-442-11	BRACKET, SIDE FL (MOLD)	BR6
53	4-546-443-11	BRACKET, UNDER FL (MOLD)	LA1
53	4-546-443-21	BRACKET, UNDER FL (MOLD)	UC2
53	4-546-443-41	BRACKET, UNDER FL (MOLD)	CR1/ECU/ LA8/CO1
53	4-546-443-61	BRACKET, UNDER FL (MOLD)	BR6
54	A-2072-562-A	COMPLE SVC (XF) BMFL BR6	CR1/ECU/ LA8/BR6
54	A-2072-563-A	COMPLE SVC (XF) BMFL CO1	CO1
54	A-2072-564-A	COMPLE SVC (XF) BMFL UC2	UC2
54	A-2072-565-A	COMPLE SVC (XF) BMFL LA1	LA1
55	1-474-620-11	GL3(CH)-STATIC CONVERTER(TV)	
56	4-565-059-11	SHEET, INSULATION(HRN L)	
*	57	4-546-473-01	BRACET, VESA(HWK)
58	2-650-770-21	SLIDE, CLAMP	
59	4-547-988-01	BRACKET, SP (LAK)	
60	4-562-155-01	BRACKET, SC (HRN)	
61	1-812-102-11	LCD PANEL (Y55QHND5)	BR6
61	1-812-103-11	LCD PANEL (Y55QHND5)	except BR6

5-1-3. CONNECTORS

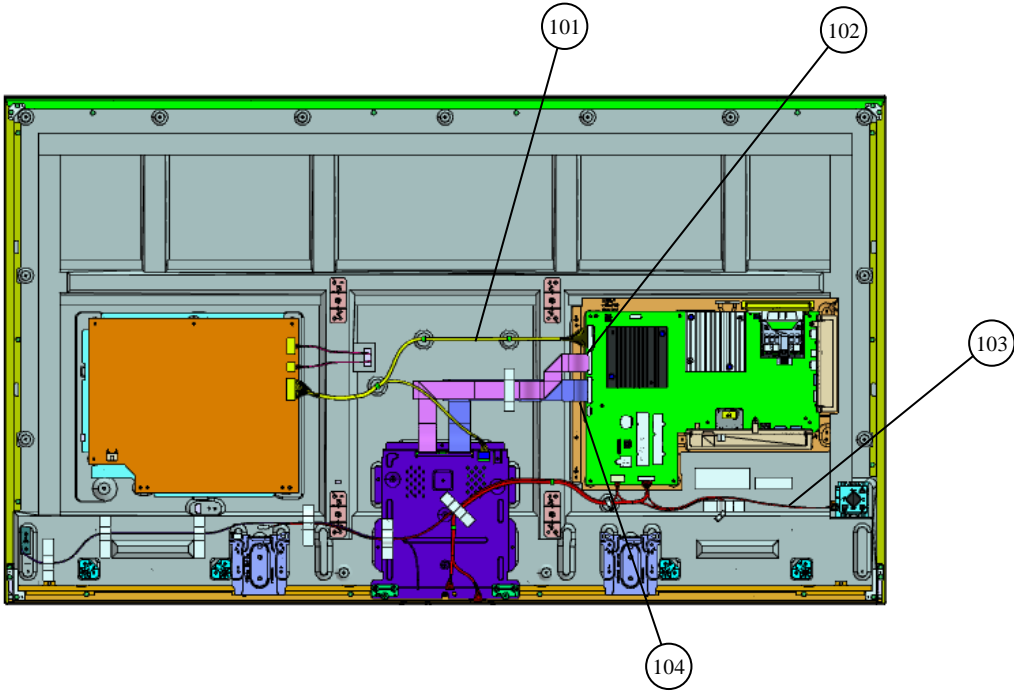

REF.NO.	PART No.	DESCRIPTION	MARK
101	1-910-110-23	CONNECTOR ASSY 28P	CN6401(GL3)-CN9000(BMFL)-TCON (1)
102	1-848-915-11	FLEXIBLE FLAT CABLE 41P (XFS)	CN3600(BMFL)-TCON (1) (except BR6)
102	1-848-927-11	FLEXIBLE FLAT CABLE 41P (XFS)	CN3600(BMFL)-TCON (1) (BR6)
103	1-910-110-24	HARNESS ASSY (MAIN)	CN1000(BMFL)-CN101(HSC3)-WIFI-SM/CN7700(BMFL)-SP (1)
104	1-848-914-11	FLEXIBLE FLAT CABLE 51P (XFS)	CN3601(BMFL)-TCON (1) (except BR6)
104	1-848-922-11	FLEXIBLE FLAT CABLE 51P (XFS)	CN3601(BMFL)-TCON (1) (BR6)

5-1-4. SCREWS

REF.	DESCRIPTION	PART No.
■	SCREW +PSW M4X10	4-159-298-01
□	SCREW , +PWH M3X6	4-452-935-11
●	SCREW, +BVTP 4X12 TYPE2 IT-3	2-580-639-01
☆	SCREW (+PSW)(M3X6)	2-990-421-41
△	SCREW, +PSW M4X8	2-580-600-11
○	SCREW, +PSW M3X8	2-580-593-01
◆	SCREW, +PSW M3X6 W12	4-256-393-11

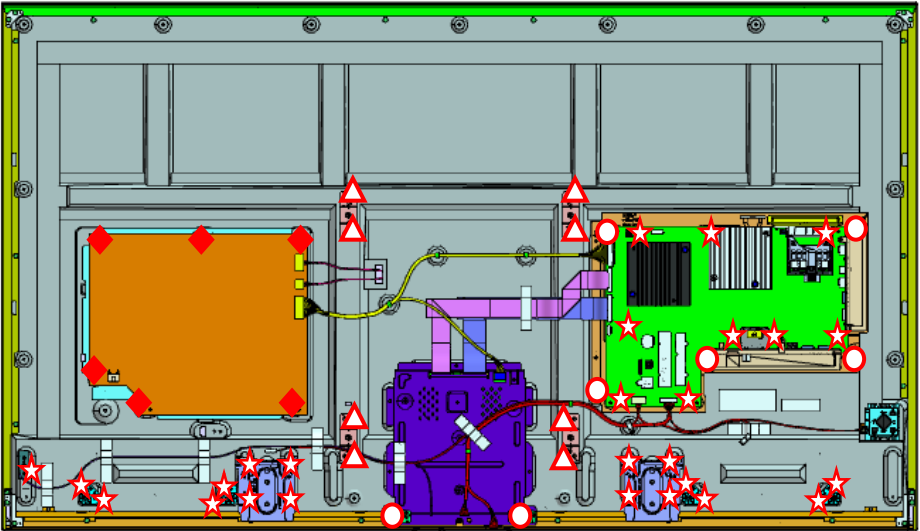
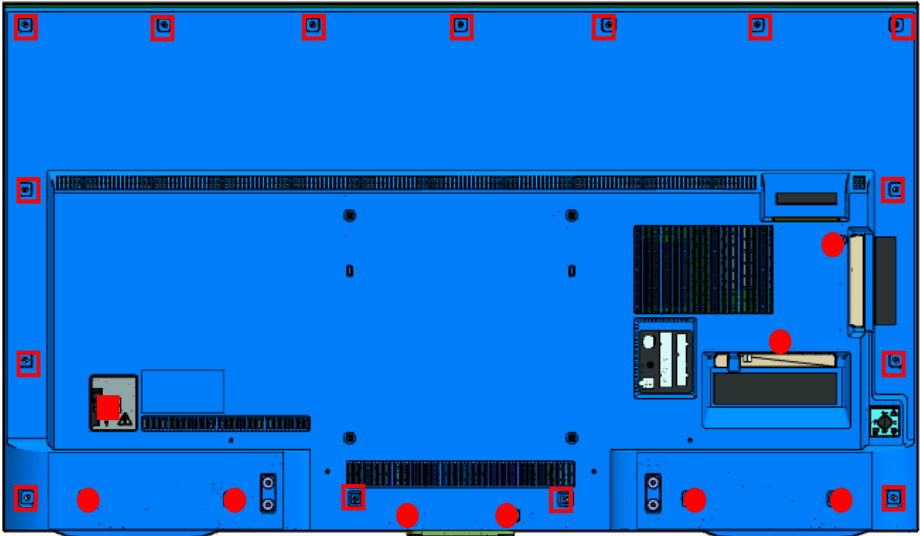

5-2. XBR-65X850C/855C/857C

5-2-1. REAR COVER

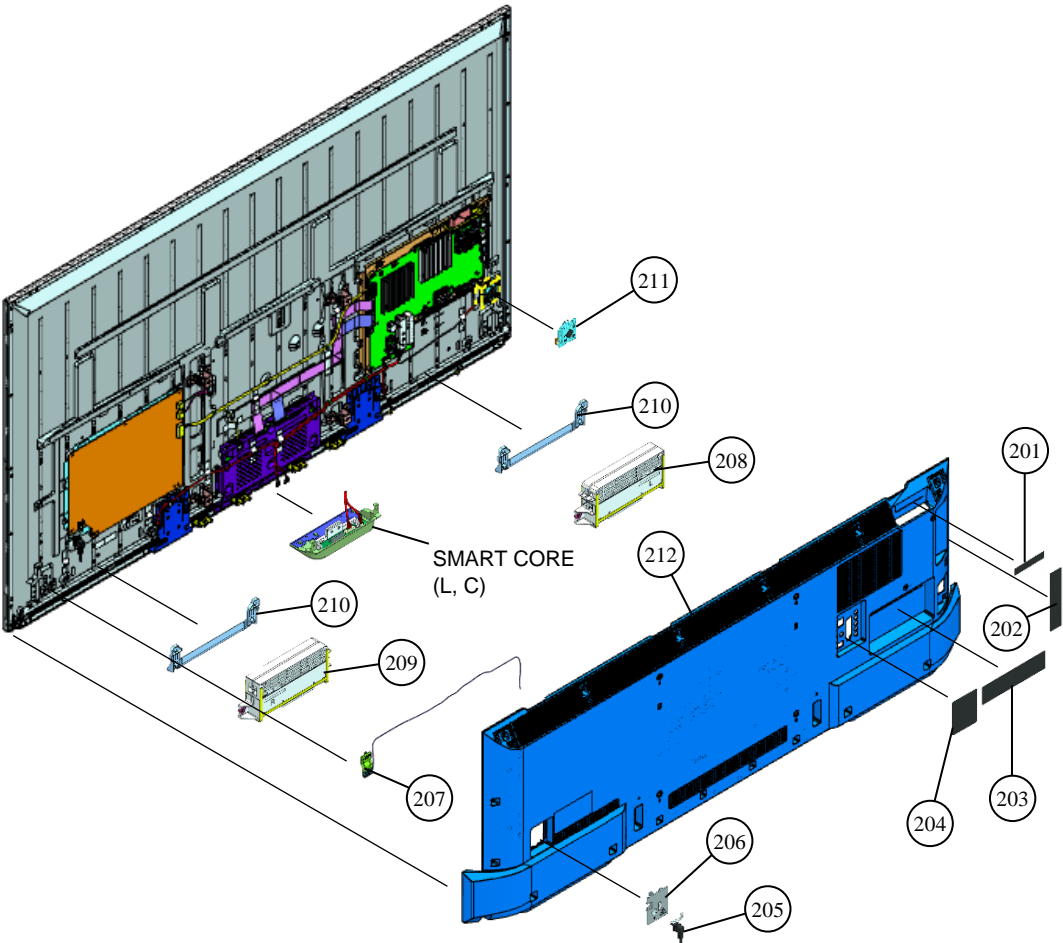

REF. No.	PART No.	DESCRIPTION	MARK	
201	4-567-609-01	LABEL, CI	CO1	
202	4-563-756-01	LABEL, SIDE TERMINAL (L)		
203	4-563-760-01	LABEL, UNDER TERMINAL	UC2	
203	4-563-760-11	LABEL, UNDER TERMINAL	LA1	
203	4-563-760-21	LABEL, UNDER TERMINAL	CO1/CR1/AR4/LA8 /BR6	
*	204	4-563-764-01	LABEL, REAR TERMINAL	UC2
204	4-563-765-01	LABEL, REAR TERMINAL	LA1/CO1/CR1 /AR4/LA8/BR6	
205	▲ 1-839-692-12	POWER-SUPPLY CORD (WITH CONN.)	AR4	
205	▲ 1-839-695-12	POWER-SUPPLY CORD (WITH CONN.)	CR1/LA8/BR6	
205	▲ 1-839-696-12	POWER-SUPPLY CORD (WITH CONN.)	UC2/LA1/CO1	
206	4-297-989-01	AC COVER	BR6	
206	4-299-531-01	AC COVER	UC2/LA1/CO1/CR1 /AR4/LA8	
207	1-754-948-11	BT ANTENNA	UC2/LA1/BR6	
207	1-754-949-11	BT ANTENNA	CO1/CR1/AR4/LA8	
208	1-859-007-11	SPEAKER BOX ASSY (L)		
209	1-859-007-21	SPEAKER BOX ASSY (R)		
210	4-546-824-01	BRACKET, SP (2L HWK) A	UC2/LA1/CO1/CR1 /AR4/LA8	
210	4-546-466-01	BRACKET, SP BARE (2L HWK)	BR6	
211	1-798-510-31	SWITCH UNIT (SM-G-WW)	UC2/LA1/CO1/CR1 /AR4/LA8	
211	1-798-510-41	SWITCH UNIT (SM-G-KIT)	BR6	
212	4-546-825-11	UNDER COVER (2L_HWK) A	UC2/LA1/CO1/CR1 /AR4/LA8	
212	A-2068-960-A	UNDER COVER (2L_HWK) A	BR6	

5-2-2. LCD PANEL

REF. No.	PART No.	DESCRIPTION	MARK
251	4-546-441-11	BRACKET, TOP FL (MOLD)	CO1
252	4-546-442-01	BRACKET, SIDE FL (MOLD)	UC2/LA1/CO1/CR 1/AR4/LA8
252	4-546-442-11	BRACKET, SIDE FL (MOLD)	BR6
253	4-546-443-11	BRACKET, UNDER FL (MOLD)	LA1
253	4-546-443-21	BRACKET, UNDER FL (MOLD)	UC2
253	4-546-443-41	BRACKET, UNDER FL (MOLD)	CO1/CR1/AR4/LA8
253	4-546-443-61	BRACKET, UNDER FL (MOLD)	BR6
254	A-2072-562-A	COMPLE SVC (XF) BMFL BR6	CR1/AR4/LA8/BR6
254	A-2072-563-A	COMPLE SVC (XF) BMFL CO1	CO1
254	A-2072-564-A	COMPLE SVC (XF) BMFL UC2	UC2
254	A-2072-565-A	COMPLE SVC (XF) BMFL LA1	LA1
255	1-474-617-11	GL1A (CH)-STATIC CONVERTER (TV)	
256	4-549-182-01	SHEET, INSULATION(HWK 2L)	
*	257	4-546-473-01	BRACET,VESA(HWK)
	258	2-650-770-21	SLIDE, CLAMP
	259	4-562-661-01	BRACKET, SC(HWK)
260	1-812-104-11	LCD PANEL(A65QVF6S)	BR6
260	1-812-105-11	LCD PANEL(A65QVF6B)	UC2/LA1/CO1/CR 1/AR4/LA8

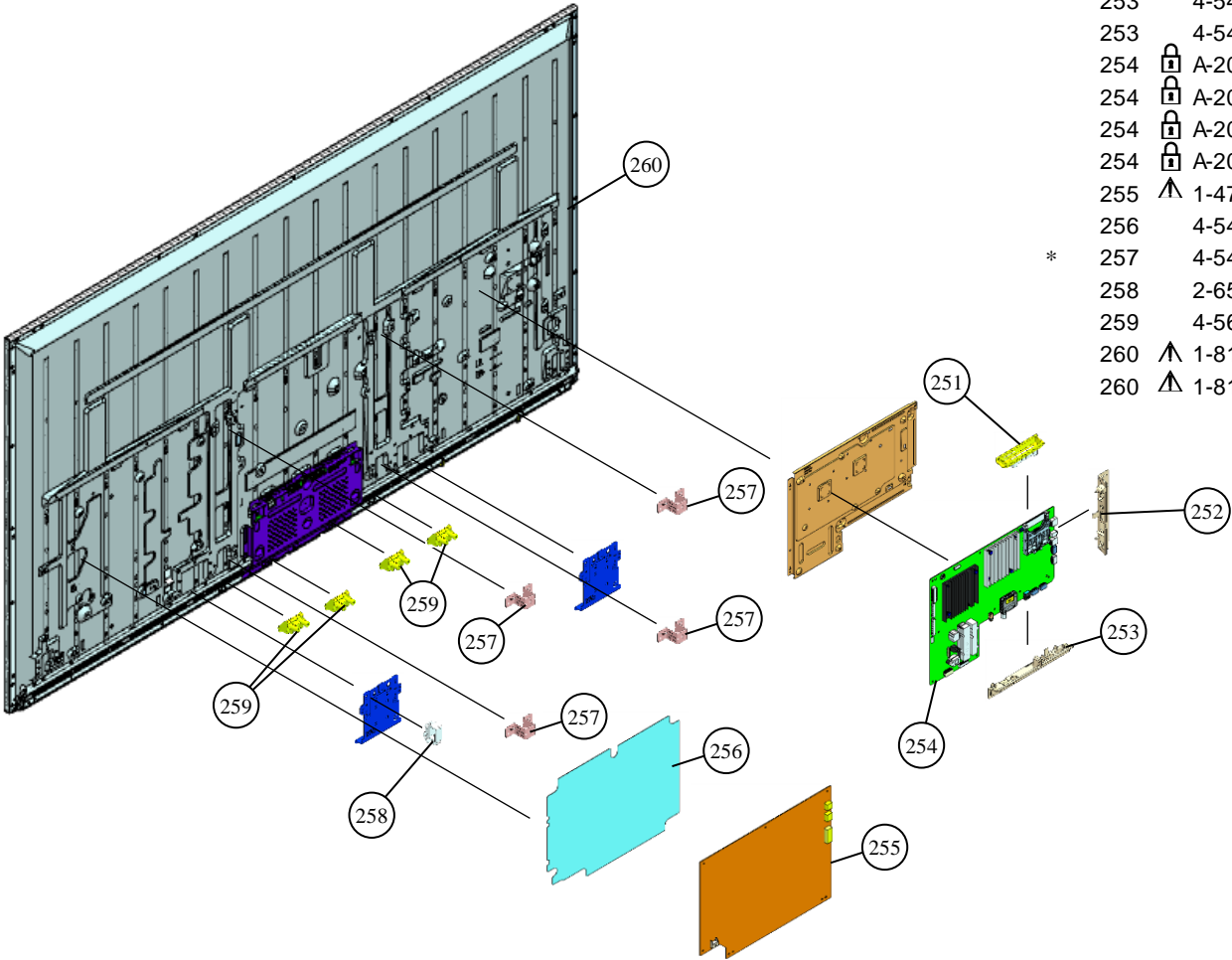

5-2-3. CONNECTORS

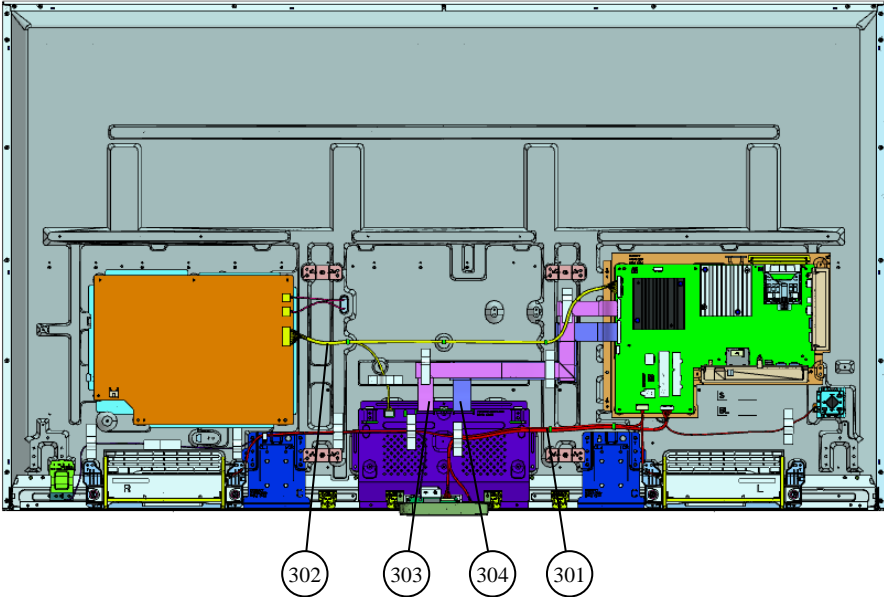

REF.NO.	PART No.	DESCRIPTION	MARK
301	1-910-109-96	HARNESS ASSY (MAIN)	CN1000(BMFL)-CN101(HSC3)-WIFI-SMCN7700(BMFL)-SP (1)
302	1-910-109-95	CONNECTOR ASSY 28P	CN6401(GL1)-CN9000(BMFL)-TCON (1)
303	1-848-870-11	CABLE, FLEXIBLE FLAT 41P	CN3600(BMFL)-TCON (1) (except BR6)
303	1-848-872-11	FLEXIBLE FLAT CABLE 41P	CN3600(BMFL)-TCON (1) (BR6)
304	1-848-871-11	CABLE, FLEXIBLE FLAT 51P	CN3601(BMFL)-TCON (1) (except BR6)
304	1-848-873-11	FLEXIBLE FLAT CABLE 51P	CN3601(BMFL)-TCON (1) (BR6)

5-2-4. SCREWS

REF.	DESCRIPTION	PART No.
■	SCREW +PSW M4X10	4-159-298-01
□	SCREW , +PWH M3X6	4-452-935-11
●	SCREW, +BVTP 4X12 TYPE2 IT-3	2-580-639-01
☆	SCREW (+PSW)(M3X6)	2-990-421-41
△	SCREW, +PSW M4X8	2-580-600-11
○	SCREW, +PSW M3X8	2-580-593-01
◆	SCREW, +PSW M3X6 W12	4-256-393-11
▲	SCREW, ORNAMENTAL M6X12	4-268-126-02

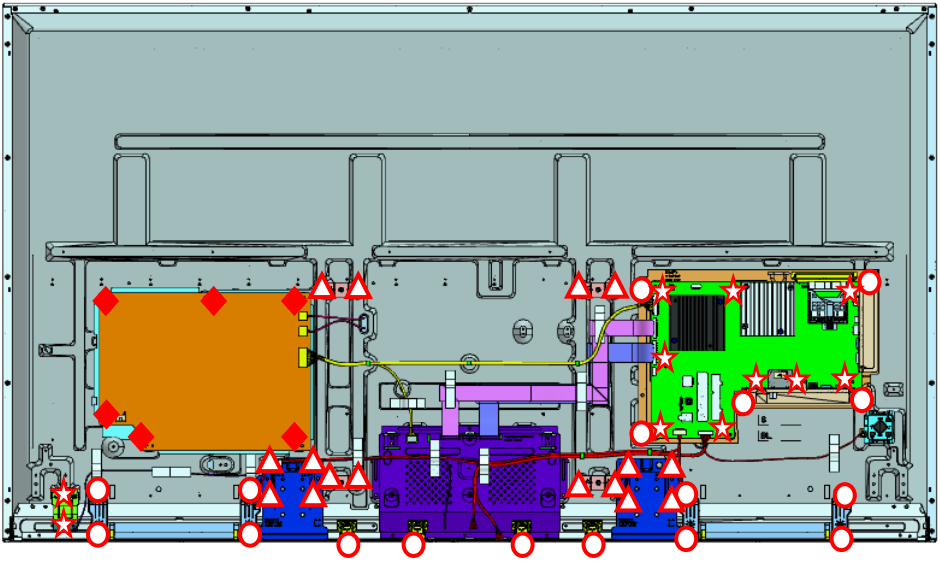
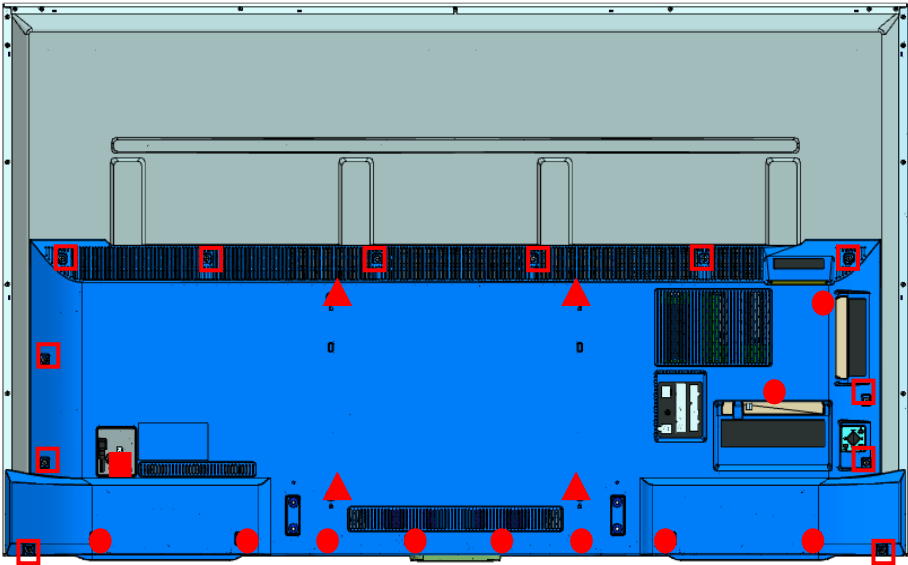

5-3. XBR-75X850C/855C

5-3-1. REAR COVER

REF. No.	PART No.	DESCRIPTION	MARK
401	4-563-756-01	LABEL, SIDE TERMINAL (L)	
402	4-563-760-01	LABEL, UNDER TERMINAL	UC2
402	4-563-760-11	LABEL, UNDER TERMINAL	LA1
402	4-563-760-21	LABEL, UNDER TERMINAL	BR6
403	4-563-764-01	LABEL, REAR TERMINAL	UC2
403	4-563-765-01	LABEL, REAR TERMINAL	BR6/LA1
404	▲ 1-839-695-12	POWER-SUPPLY CORD (WITH CONN.)	BR6
404	▲ 1-839-696-12	POWER-SUPPLY CORD (WITH CONN.)	UC2/LA1
405	4-297-989-01	AC COVER	BR6
405	4-299-531-01	AC COVER	UC2/LA1
406	1-754-949-11	BT ANTENNA	
407	1-859-007-11	SPEAKER BOX ASSY (L)	
408	1-859-007-21	SPEAKER BOX ASSY (R)	
409	4-546-824-01	BRACKET, SP (2L HWK) A	UC2/LA1
409	4-546-466-01	BRACKET, SP BARE (2L HWK)	BR6
410	1-798-510-31	SWITCH UNIT (SM-G-WW)	UC2/LA1
410	1-798-510-41	SWITCH UNIT (SM-G-KIT)	BR6
411	4-546-826-11	UNDER COVER (3L_HWK) A	UC2/LA1
411	A-2068-961-A	UNDER COVER (3L_HWK) A	BR6

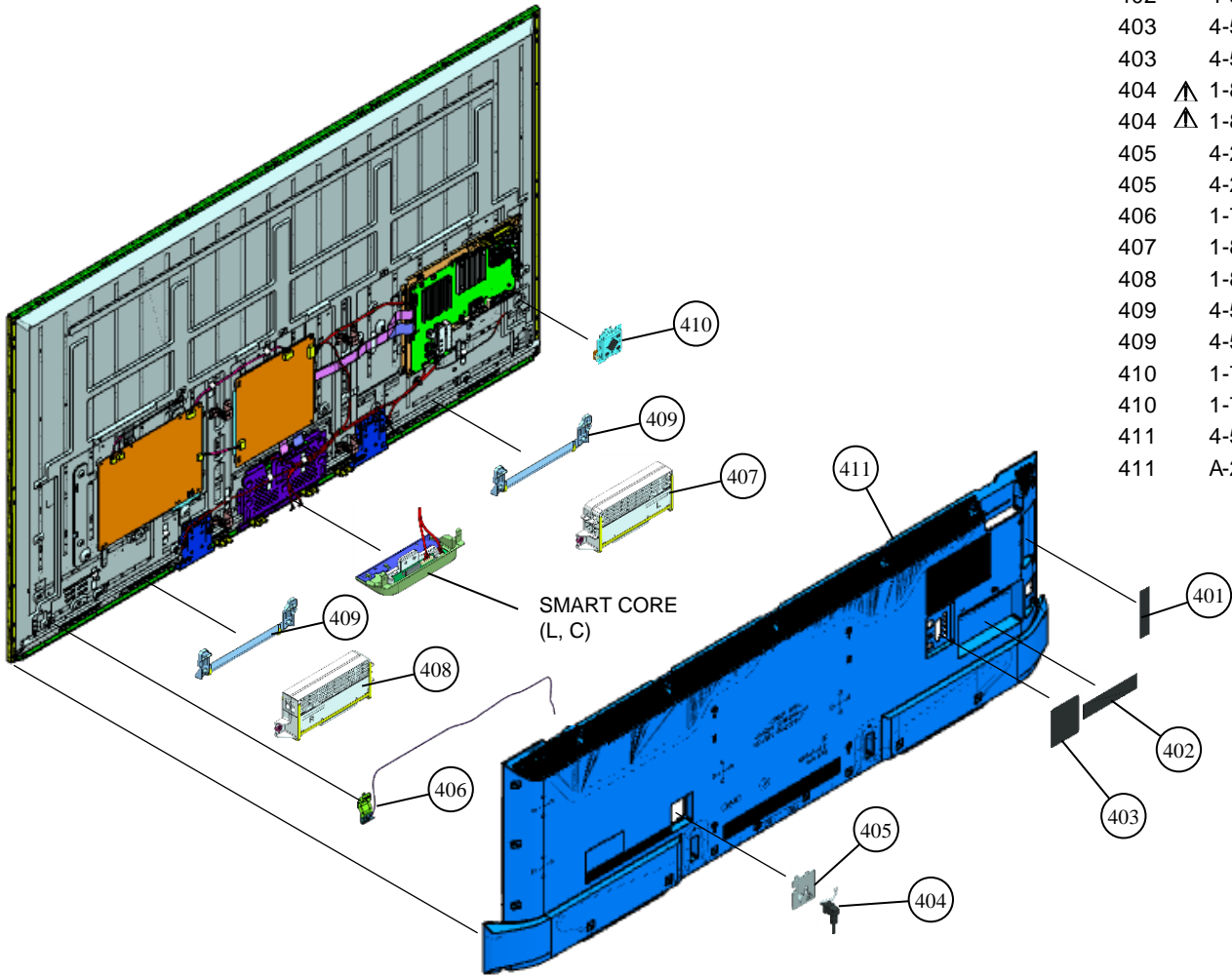

5-3-2. LCD PANEL

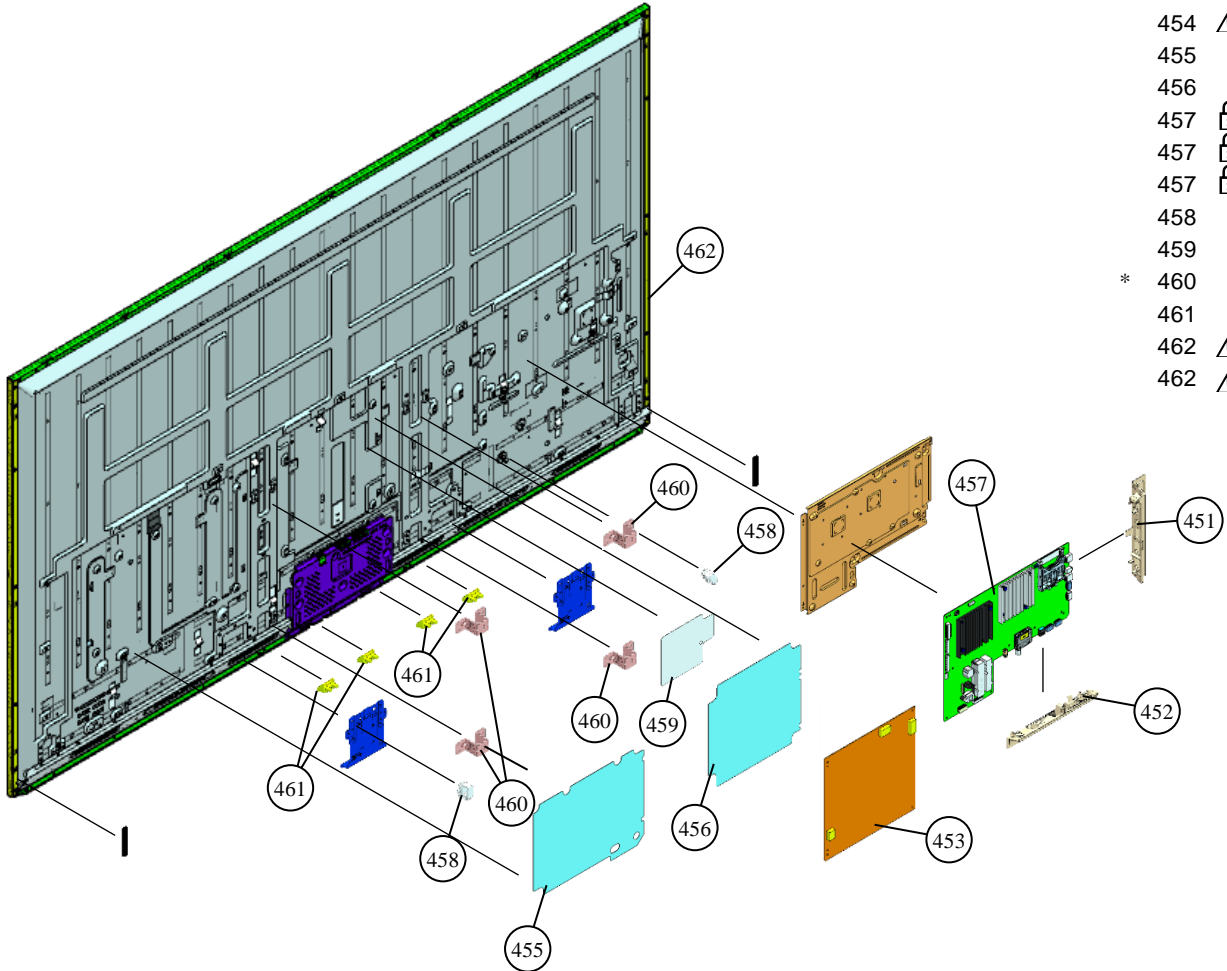

REF. No.	PART No.	DESCRIPTION	MARK
451	4-546-442-01	BRACKET, SIDE FL (MOLD)	UC2/LA1
451	4-546-442-11	BRACKET, SIDE FL (MOLD)	BR6
452	4-546-443-11	BRACKET, UNDER FL (MOLD)	LA1
452	4-546-443-21	BRACKET, UNDER FL (MOLD)	UC2
452	4-546-443-61	BRACKET, UNDER FL (MOLD)	BR6
453	▲ 1-474-616-11	G4-STATIC CONVERTER (TV)	
454	▲ 1-474-615-11	GL2-STATIC CONVERTER (TV)	
455	4-549-183-01	SHEET, INSULATION (HWK 3L)	
456	4-549-184-02	SHEET, INSULATION (HWK 3L SYS)	
457	🔒 A-2072-562-A	COMPLE SVC (XF) BMFL BR6	BR6
457	🔒 A-2072-564-A	COMPLE SVC (XF) BMFL UC2	UC2
457	🔒 A-2072-565-A	COMPLE SVC (XF) BMFL LA1	LA1
458	2-650-770-21	SLIDE, CLAMP	
459	4-567-636-01	TAPE, FFC (HWK 3L)	
*	460	4-546-473-01	BRACET, VESA(HWK)
461	4-562-661-01	BRACKET, SC(HWK)	
462	▲ 1-812-106-11	LCD PANEL (B75QF59S)	BR6
462	▲ 1-812-107-11	LCD PANEL (B75QF59B)	UC2/LA1

5-3-3. CONNECTORS

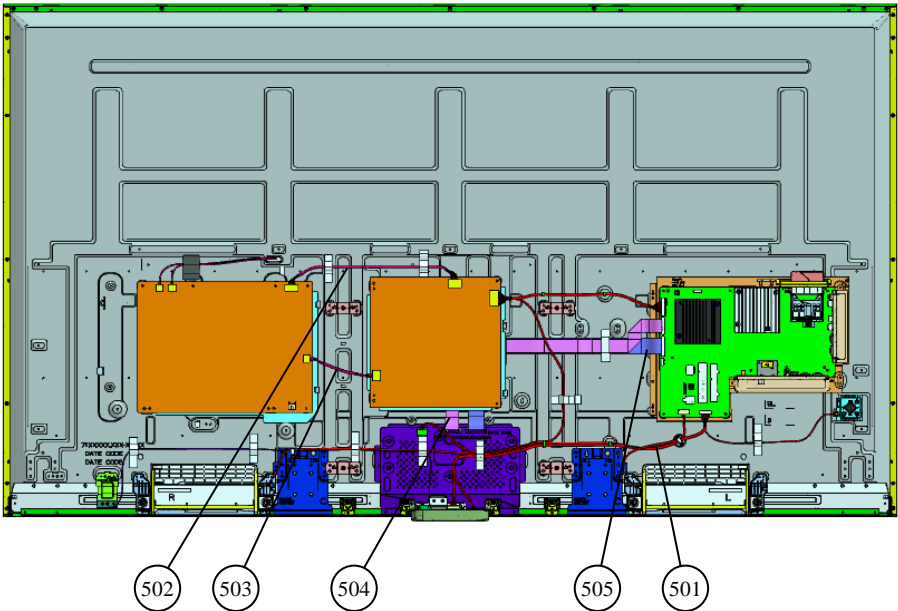

REF.NO.	PART No.	DESCRIPTION	MARK
501	1-910-109-97	HARNESS ASSY (GBT/MAIN)	CN6401(G4)-CN9000(BMFL)-TCON/CN1000(BMFL)-CN101(HSC3)-WIFI-SM/CN7700(BMFL)-SP (1)
502	1-910-109-98	CONNECTOR ASSY 9P	CN6803(GL2)-CN6402(G4) (1)
503	1-848-869-11	CONNECTOR ASSY, 3P	CN6102(GL2)-CN6103(G4) (1)
504	1-848-890-11	FLEXIBLE FLAT CABLE 41P	CN3600(BMFL)-TCON (1)
505	1-848-891-11	FLEXIBLE FLAT CABLE 51P	CN3601(BMFL)-TCON (1)

5-3-4. SCREWS

REF.	DESCRIPTION	PART No.
■	SCREW +PSW M4X10	4-159-298-01
□	SCREW , +PWH M3X6	4-452-935-11
●	SCREW, +BVTP 4X12 TYPE2 IT-3	2-580-639-01
☆	SCREW (+PSW)(M3X6)	2-990-421-41
△	SCREW, +PSW M4X8	2-580-600-11
○	SCREW, +PSW M3X8	2-580-593-01
◆	SCREW, +PSW M3X6 W12	4-256-393-11
▲	SCREW, ORNAMENTAL M6X12	4-268-126-02

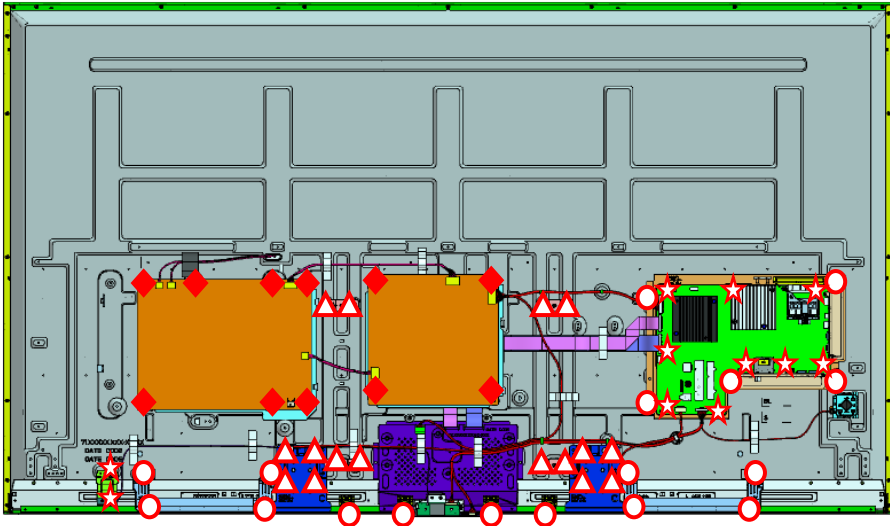
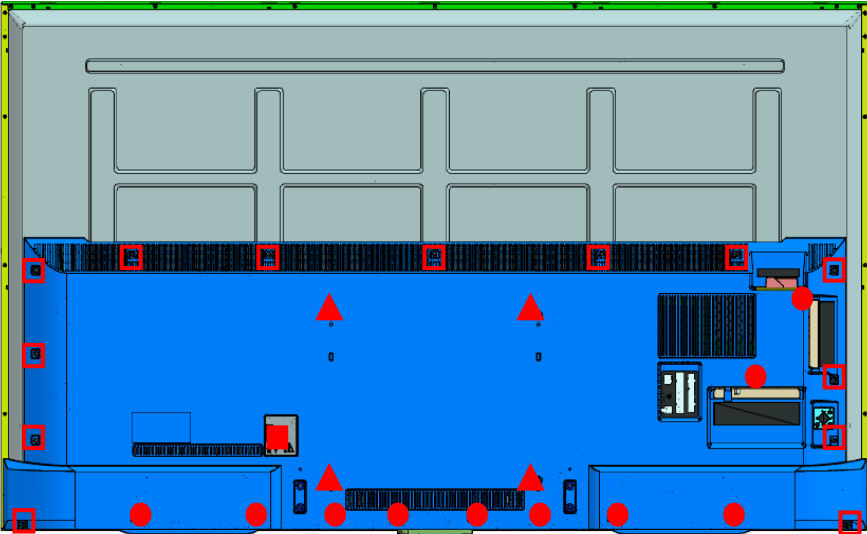

5-4. XBR-55X850C/855C/857C

5-4-1. SMART CORE (M,L)

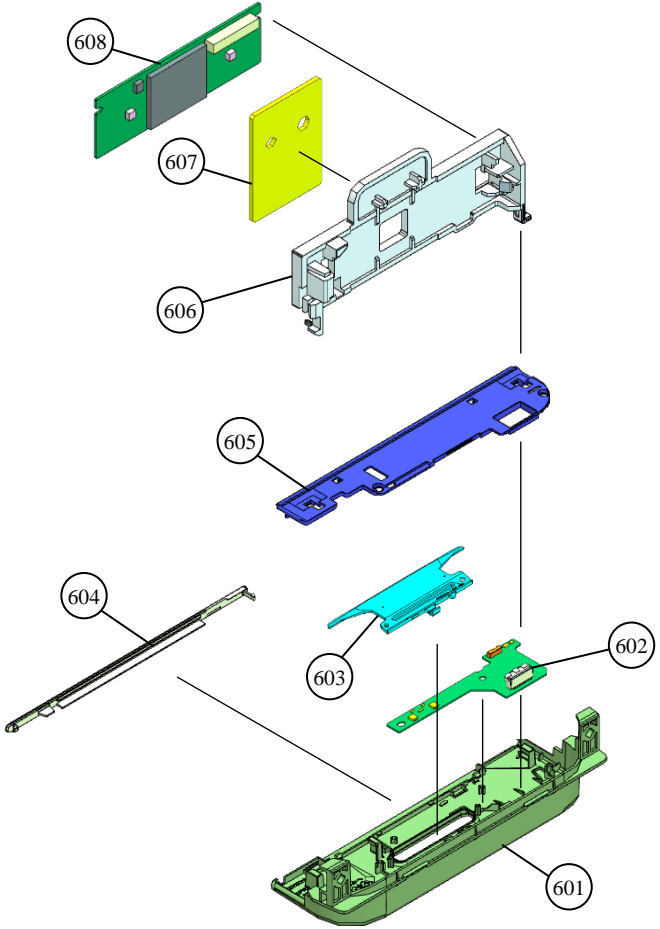

REF. No.	PART No.	DESCRIPTION	MARK
601	4-547-392-01	CASE, BOTTOM (M)	BR6
601	4-564-315-01	CASE, BOTTOM (M)	except BR6
602	A-2066-088-A	HSC3_S_M MOUNT	
603	4-547-390-01	LIGHT, GUIDE	BR6
603	4-564-313-01	LIGHT, GUIDE	except BR6
604	4-547-389-01	PANEL, ORNAMENT	BR6
604	4-564-312-01	PANEL, ORNAMENT	except BR6
605	4-547-395-01	COVER, TOP	BR6
605	4-564-317-01	COVER, TOP	except BR6
606	4-547-397-01	BRACKET, WIFI	BR6
606	4-564-318-01	BRACKET, WIFI	except BR6
607	4-566-841-01	HEAT SINK L(SC)	
608	1-458-853-11	WLAN/BT MODULE(11AC)	except BR6
608	1-458-853-21	WLAN/BT MODULE(11AC) BRZ	BR6

5-5. XBR-65X850C/855C/857C, 75X850C/855C

5-5-1. SMART CORE (L,C)

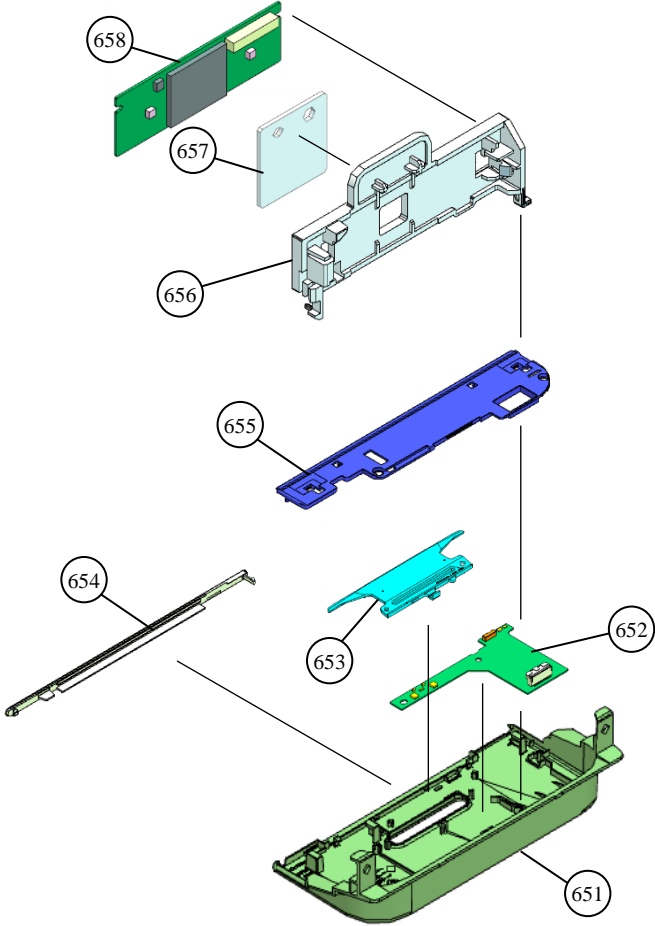

REF. No.	PART No.	DESCRIPTION	MARK
651	4-547-393-01	CASE, BOTTOM (L)	BR6
651	4-564-316-01	CASE, BOTTOM (L)	except BR6
652	A-2066-086-A	HSC3_L MOUNT	
653	4-547-390-01	LIGHT, GUIDE	BR6
653	4-564-313-01	LIGHT, GUIDE	except BR6
654	4-547-389-01	PANEL, ORNAMENT	BR6
654	4-564-312-01	PANEL, ORNAMENT	except BR6
655	4-547-395-01	COVER, TOP	BR6
655	4-564-317-01	COVER, TOP	except BR6
656	4-547-397-01	BRACKET, WIFI	BR6
656	4-564-318-01	BRACKET, WIFI	except BR6
657	4-547-207-01	HEAT SINK(SC)	
658	1-458-853-11	WLAN/BT MODULE(11AC)	except BR6
658	1-458-853-21	WLAN/BT MODULE(11AC) BRZ	BR6

5-6. OTHER PART

5-6-1. MISCELLANEOUS

PART No.	DESCRIPTION	MARK
3-876-036-71	UNI-LABEL, BLANK	
4-262-708-04	CLAMPER, CABLE	
4-449-743-01	SCREW, +PSW M5X16	
4-534-964-01	PULLEY, STAND (HWI)	65" /75"
4-535-586-01	BADGE, XBR LOGO(H3.7)	
* 4-547-493-01	HEAT, SINK (MUFF)	
* 4-548-743-01	HOLDER, HS WS (MUF)	
4-549-186-01	SHEET, THERMAL(BM)	
* 4-549-188-01	HOLDER(HS MUF)	
* 4-549-395-01	HEAT SINK (MUFF C)	
4-549-528-11	SHEET, THERMAL (SC)	
4-566-117-01	GASKET (BMF)	
4-567-123-01	GASKET (HWK STD)	
4-570-857-01	BADGE, XBR LOGO (H3.1)	
7-600-031-97	TAPE (3M 1350FB-1)15MMX66M BLK	
* 7-600-040-44	ADHESIVE (SV380C) 333CC GRY	

5-6-2. ACCESSORIES

PART No.	DESCRIPTION	MARK
3-876-036-71	UNI-LABEL, BLANK	
4-262-708-04	CLAMPER, CABLE	
1-458-628-21	3D EYEWEAR TDG-BT500A(SVC)GA+LA	55" BR6/75" BR6
1-492-949-11	REMOTE COMMANDER (RMF-TX100U)	75" UC2/LA1 65" except BR6 55" except BR6
1-492-949-21	REMOTE COMMANDER (RMF-TX100U)	BR6
1-492-978-21	REMOTE COMMANDER (RMT-TX100U)	UC2/LA1
1-492-975-21	REMOTE COMMANDER (RMT-TX100B)	65" CO1/CR1/AR4/LA8 55" CR1/ECU/LA8/CO1
1-492-975-31	REMOTE COMMANDER (RMT-TX100B)	BR6
1-785-504-21	ADAPTOR, CONVERSION	CR1/ECU/LA8
* 1-848-803-11	RCA CONVERSION CABLE	
4-546-910-01	STAND NECK ASSY	65" except BR6 75" UC2/LA1
A-2069-466-A	STAND NECK ASSY	65" BR6/75" BR6
4-559-310-01	STAND NECK ASSY (LAK)	55" except BR6
A-2073-679-A	STAND, NECK ASSY (LAK)	55" BR6
4-549-374-01	STAND, SHAFT (3L HWK) A	75" UC2/LA1
A-2068-967-A	STAND, SHAFT (3L HWK) A	75" BR6
4-549-373-01	STAND, SHAFT (2L HWK) A	65" except BR6
A-2068-966-A	STAND, SHAFT (2L HWK) A	65" BR6
4-562-159-01	STAND (L HRN) A	55" except BR6
A-2073-680-A	STAND (L HRN) A	55" BR6
* 4-562-216-11	REFERENCE GUIDE	UC2
* 4-562-217-31	REFERENCE GUIDE	LA1
* 4-562-220-31	REFERENCE GUIDE	AR4
4-562-222-11	STARTUP GUIDE	BR6
1-845-283-14	IR BLASTER	UC2/LA1
4-562-758-01	BAG, SCREW A (EGL)	65"/75" except BR6
* 4-567-081-01	SCREW, +PSW M6X12	
* 4-567-082-01	SCREW, +PSW M5X20	
4-449-743-01	SCREW, +PSW M5X16	55"

END

APPENDIX-1

How to USB update

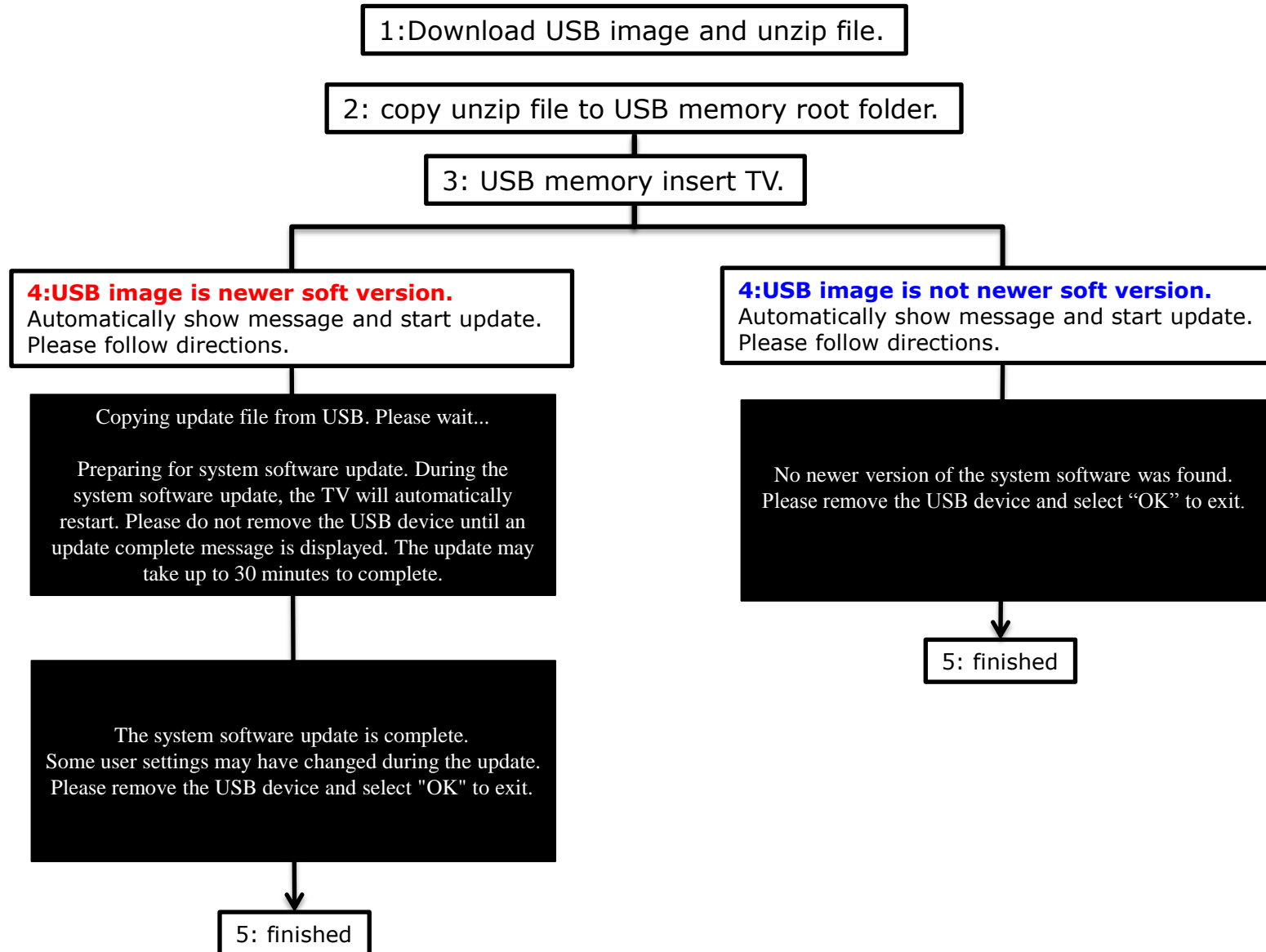

Software update for B board replacement

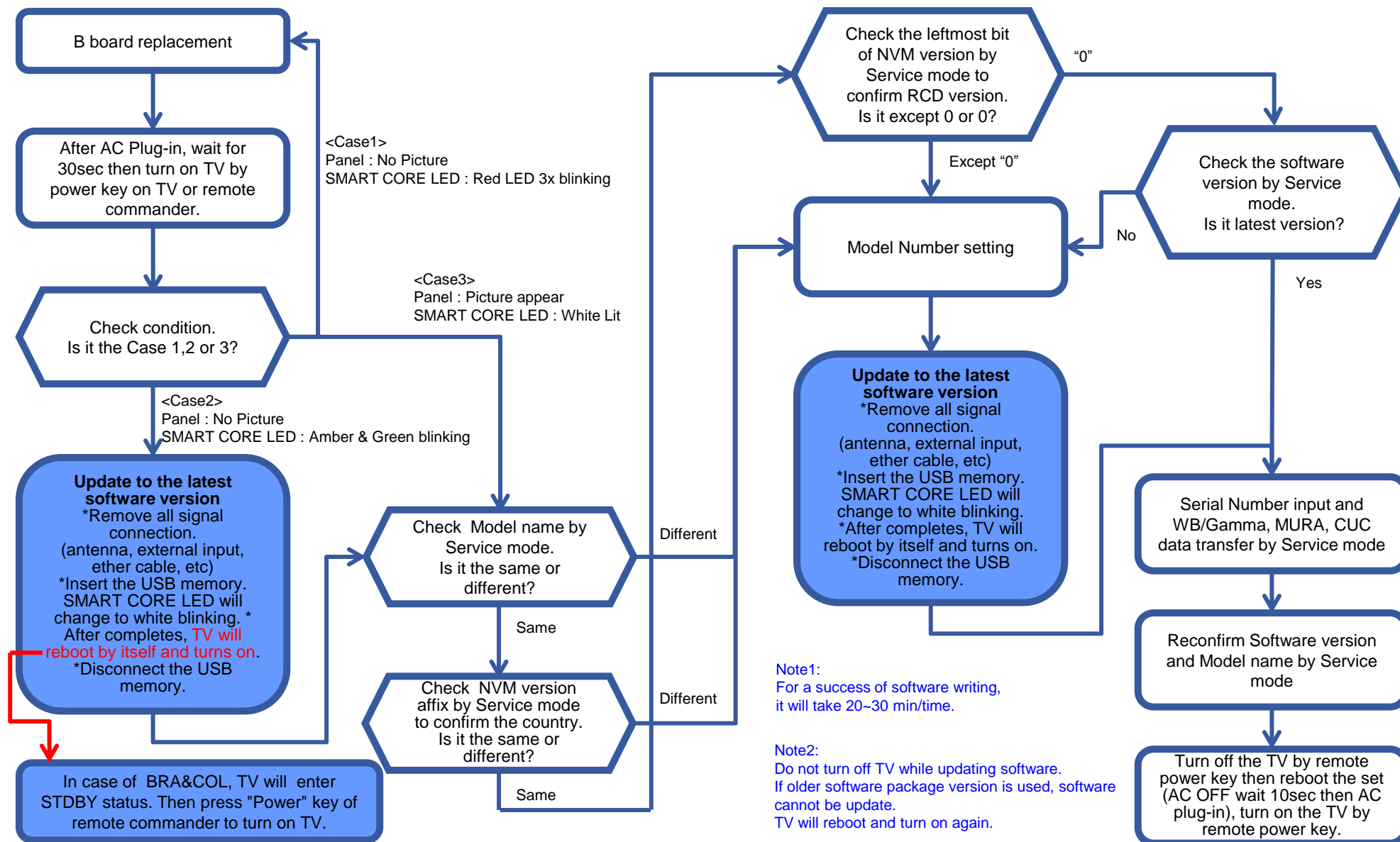

Software update for Panel/T-CON replacement

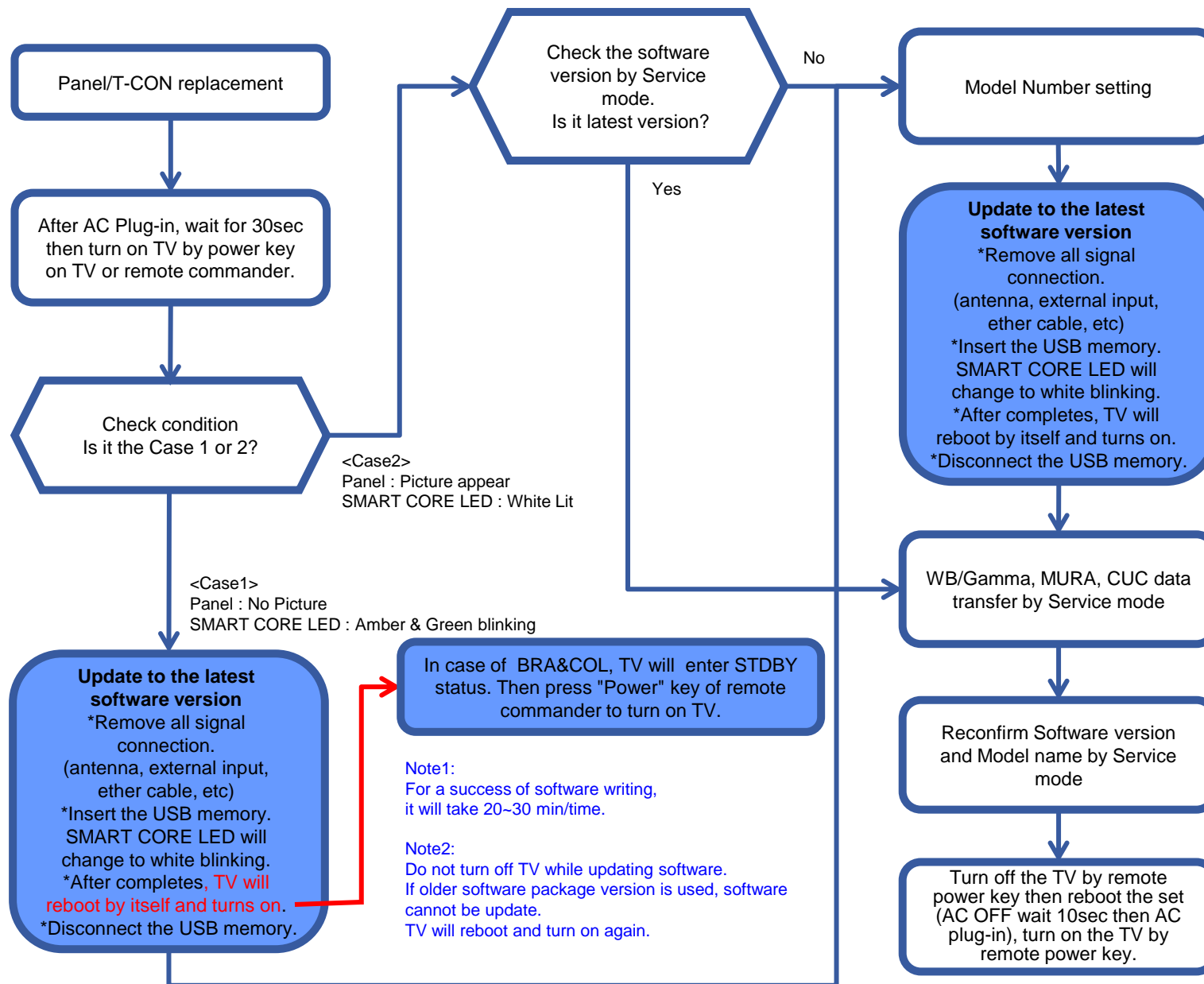

APPENDIX-2

Wire Dressing (XBR-55)

-  VA Tape x8
• Fix wire
-  Harness Tie x5
• Fix wire
-  Slide Clamp x2
• Hold wires

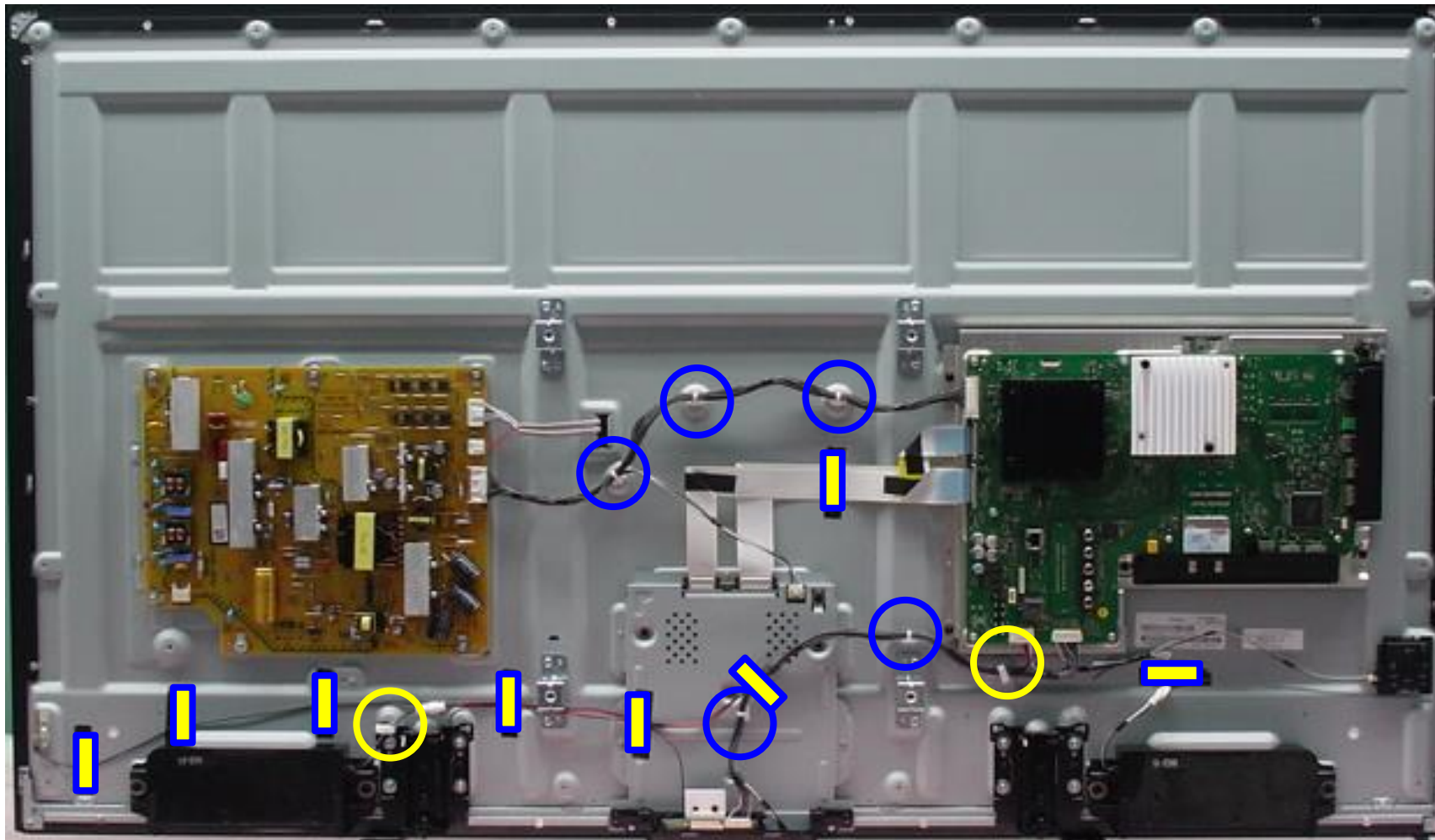

Wire Dressing (XBR-65)

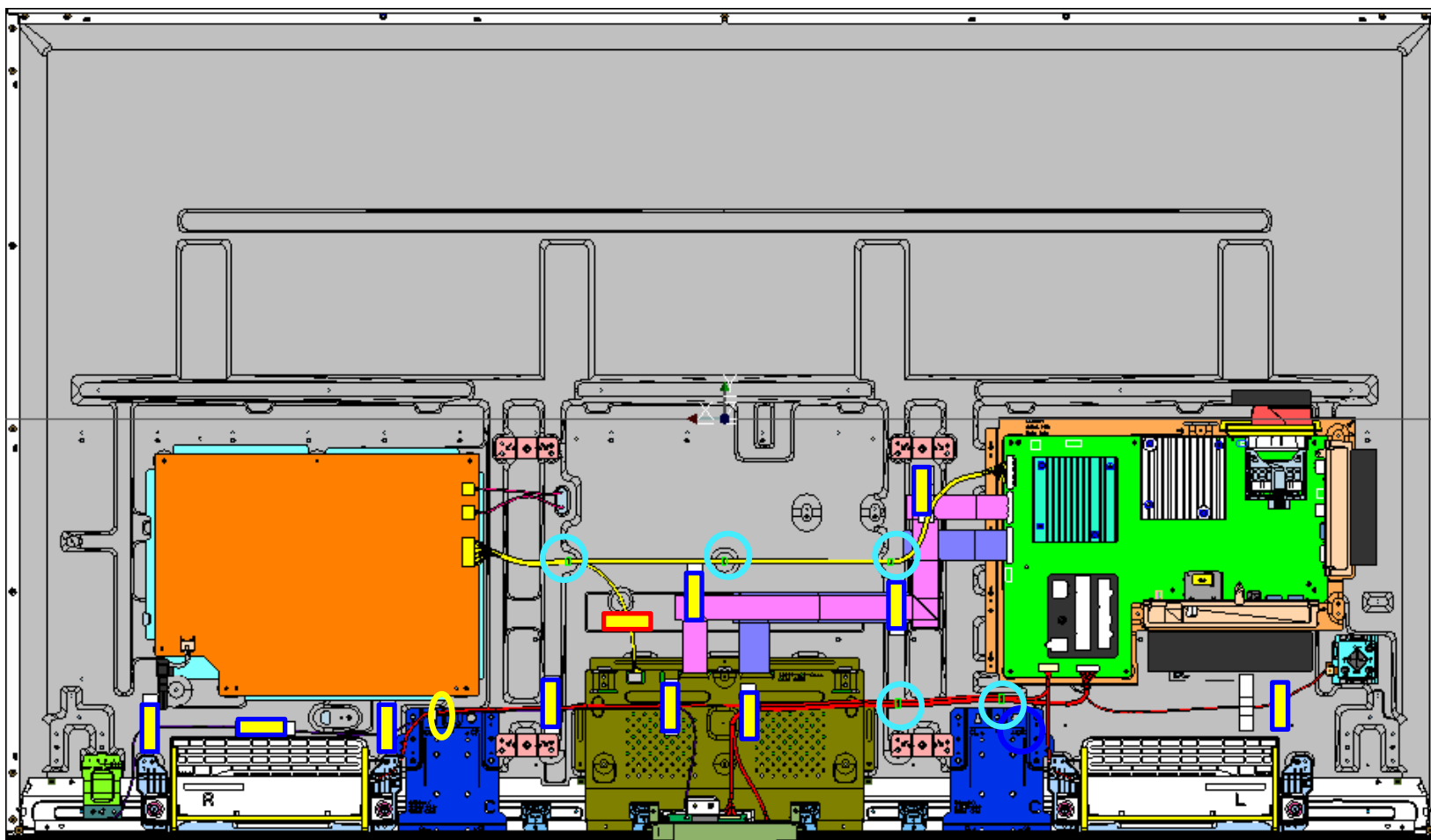

Wire Dressing (XBR-75)

- VA Tape x10
• Fix wire
- Harness Tie x4
• Fix wire
- Slide Clamp x2
• Hold wires

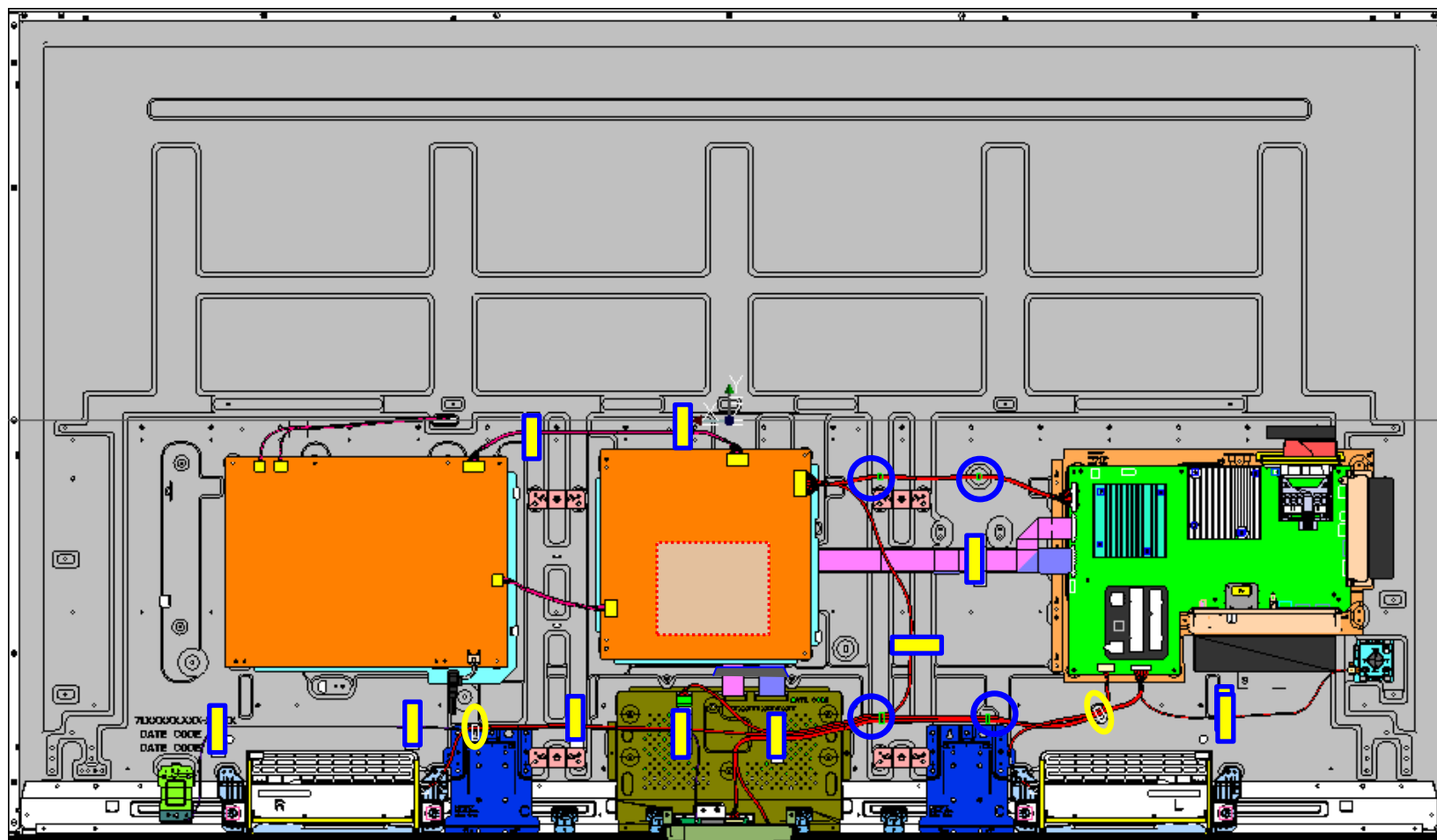

APPENDIX-3

HANDLING GUIDANCE

Unpacking(1/2)

1. Take out panel from carton box with proper number of operator.



MINIMUM NUMBER OF OPERATOR
XBR-55
2

2. Take out panel straight out from carton box.

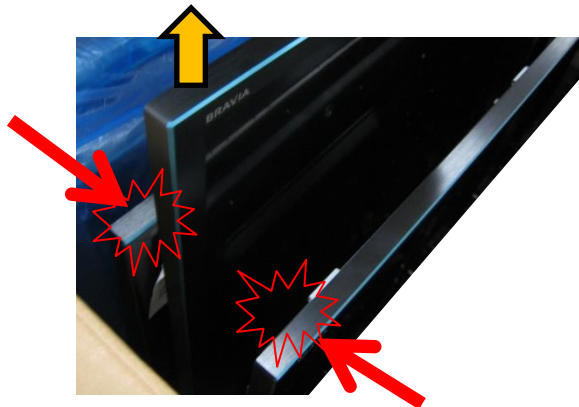

When taking out a panel, be careful not to hit front panel and back panel.

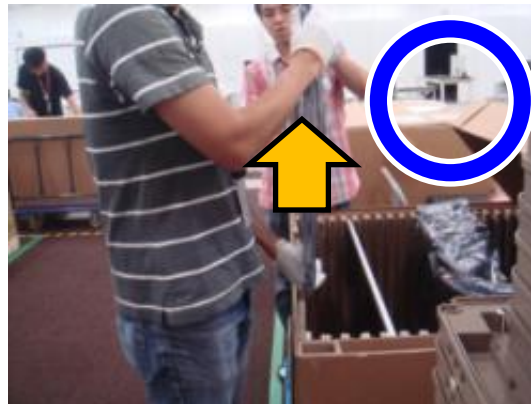

HANDLING GUIDANCE

Unpacking(2/2)

- Do not hold or press glass (TFT cell).

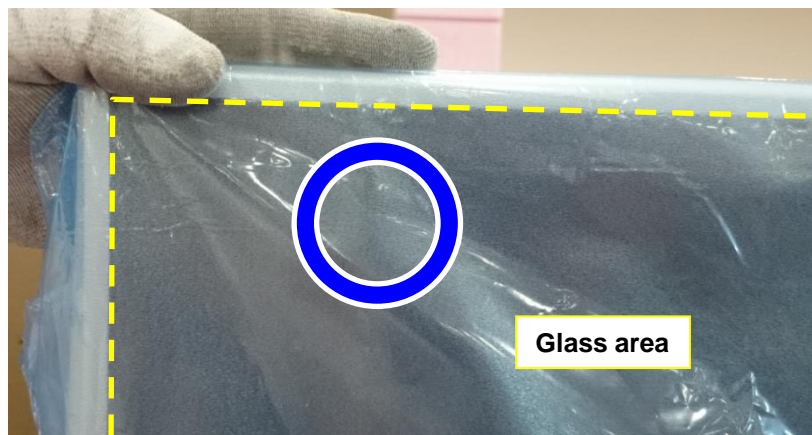

- Put in "separator board" between panel and panel.

When "vacuum handling jig" is used.



When taking out a panel, be careful not to hit next panel module.

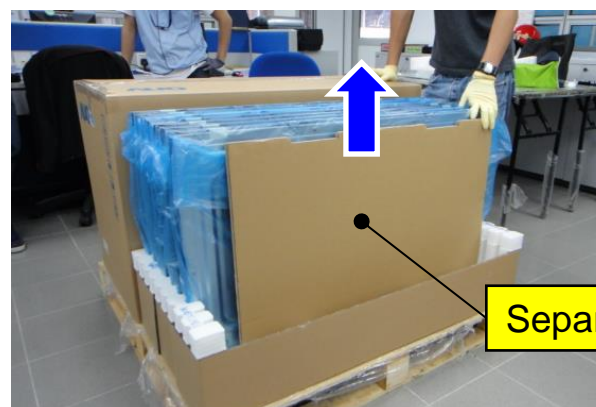

*Please prepare "Separator board" by yourself.

HANDLING GUIDANCE

Carrying (1/2)

DO NOT HOLD PANEL HORIZONTALLY AT ALL TIMES.

MINIMUM NUMBER OF OPERATOR

XBR-55

2

1. Carry panel vertically.



PANEL WILL WARP IF HANDLED LIKE THIS PICTURE

2. Do not hold glass area(TFT Cell area).

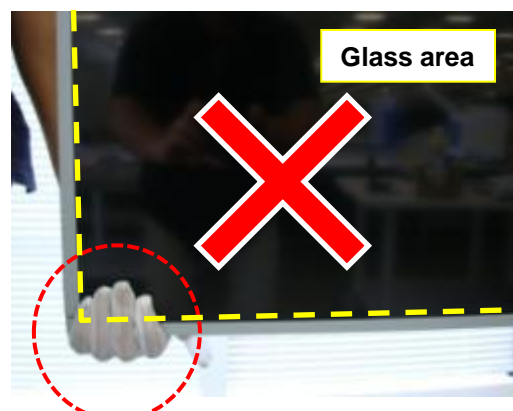
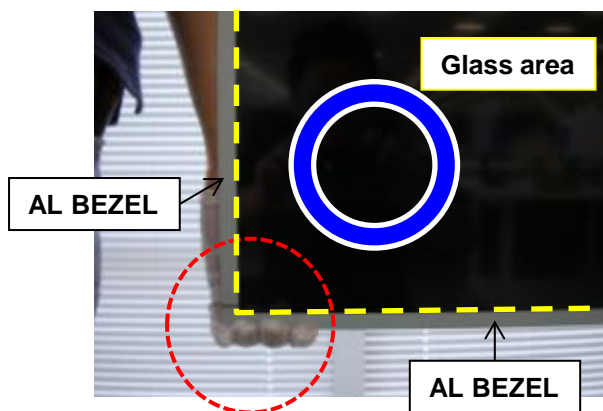

HANDLING GUIDANCE

Carrying (2/2)

3. When carrying by only 1 person, hold panel at top and bottom center position.

MINIMUM NUMBER OF OPERATOR
XBR-55
2

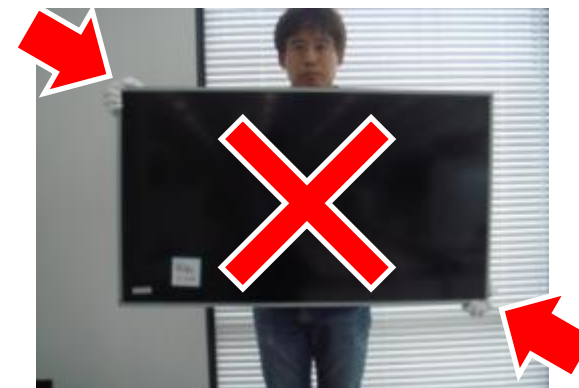
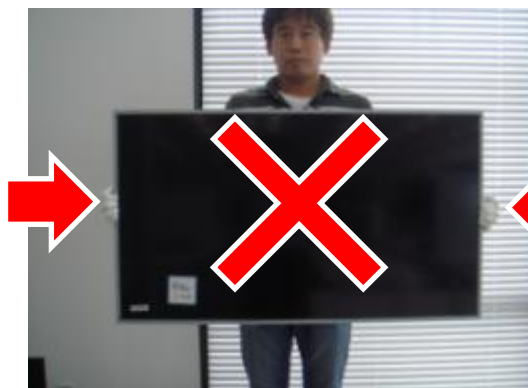
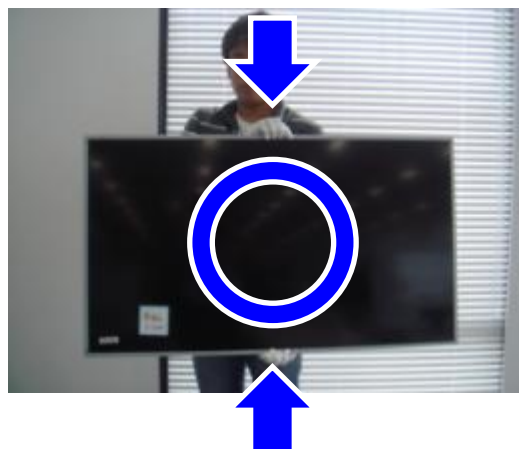

4. For large panels, sizes 49" or larger, hold panel by 2 people.



HANDLING GUIDANCE

Placing to table

Follow guidelines below.

MINIMUM NUMBER OF OPERATOR
XBR-55
2

1. Steps to place panel to table.



(1) Place vertically.

(2) Change hold position.

(3) Place to table.

2. Place panel by 2 people.



3. Place panel within table surface.



4. Table must not have any step.

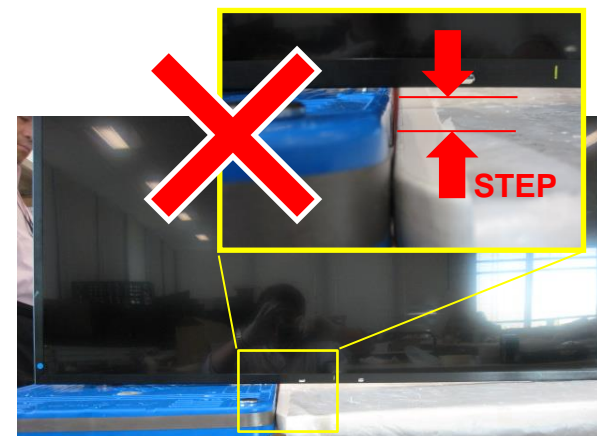

HANDLING GUIDANCE

Others

1. Do not press panel during fixing screw.

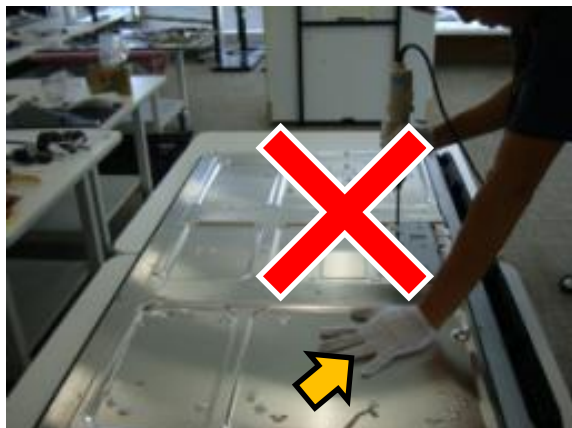

2. Do not hold or touch glass (TFT cell) at all times.



3. When attaching or detaching vacuum handling jig to panel, maximum force on panel shall be less than 100N total.

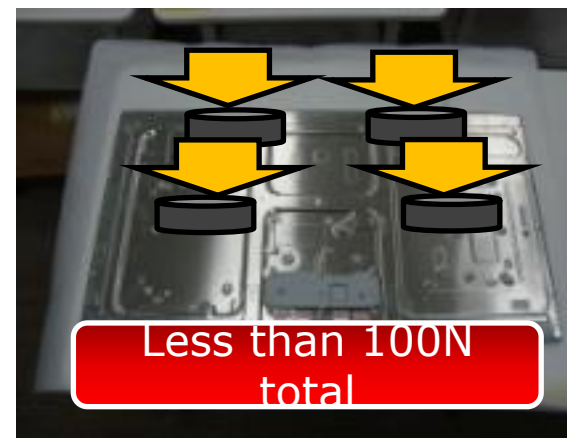

4. Operator must wear gloves.
Do not touch Panel module without gloves.

